



Fire assessment report

Service penetrations protected with
Protecta FR Collars in accordance with
AS 1530.4:2014 and AS 4072.1:2005

Sponsor: Polyseam Ltd

Report number: 5147800B Revision: R3.3 Reference number: FAS190125

Issued date: 9 February 2022 Expiry date: 30 April 2026

Quality management

Version	Date	Information about the report			
R1.0	Issue: 24/05/2018	Reason for issue	Report issued to Polyseam Ltd for review and comment.		
		Prepared by	Reviewed by	Authorised by	
		Name	Mahmoud Akl	Omar Saad	Omar Saad
R2.0	Issue: 28/10/2019	Reason for issue	Revised to include the additional testing of several types of plastic pipes and cables.		
		Prepared by	Reviewed by	Authorised by	
		Name	Mahmoud Akl	Omar Saad	Omar Saad
R3.0	Issue: 27/04/2021	Reason for issue	Additional systems added and report revalidated for a further five years.		
		Prepared by	Reviewed by	Authorised by	
		Name	Sukhi Sendanayake	Mahmoud Akl	Omar Saad
R3.1	Issue: 17/05/2021	Reason for issue	Report re-issued after addressing comments from report sponsor.		
		Prepared by	Reviewed by	Authorised by	
		Name	Sukhi Sendanayake	Mahmoud Akl	Mahmoud Akl
R3.2	Issue: 21/05/2021	Reason for issue	Report re-issued after addressing further comments from report sponsor.		
		Prepared by	Reviewed by	Authorised by	
		Name	Sukhi Sendanayake	Mahmoud Akl	Mahmoud Akl
R3.3	Issue: 9/02/2022	Reason for issue	Report re-issued after addressing further comments from report sponsor.		
		Prepared by	Reviewed by	Authorised by	
	Expiry: 30/04/2026	Name	Mohammed Mutafi	Mahmoud Akl	Mahmoud Akl
	Signature				

Executive summary

This report documents the findings of the assessment undertaken to determine the expected fire resistance levels (FRL) of service penetrations protected with Protecta FR Collars if tested in accordance with AS 1530.4:2014 and assessed in accordance with AS 4072.1:2005.

Protecta FR Collar is a pipe closure device used to form penetration seals where combustible pipes, cables and metal pipes with insulation penetrate walls and floors. The intended use of system Protecta FR Collar is to reinstate the fire resistance performance of flexible wall and rigid wall and floor constructions, where they are penetrated by services.

The analysis in sections 5 to 7 of this report found that the proposed systems together with the described variations are likely to achieve the FRLs given, if tested in accordance with AS 1530.4:2014 and assessed in accordance with AS 4072.1:2005.

Table 1 Variations and assessment outcome

Item	Reference test	Variations	Fire resistance levels (FRL)
1.	As given in Appendix B	Assess the likely fire resistance performance of the services if tested in accordance with AS 1530.4:2014 and AS 4072.1:2005.	As provided in section 5.
2.		Assess the performance of various types and sizes of cables, metallic pipes, composite pipes and plastic pipes protected with Protecta FR Acrylic sealant and other supplementary fire sealing systems.	As provided in section 6.
3.		In flexible and rigid wall systems: <ul style="list-style-type: none"> Flexible wall systems must have a minimum thickness of 75 mm and consist of steel or timber studs lined on both faces with 1 layer of minimum 12.5 mm thick fire rated plasterboard. The achieved FRLs are applicable to a flexible wall system with optional insulation and the aperture can optionally be lined. For timber framed walls, it is required that no part of the penetration seal is closer than 100 mm to a stud, the cavity is closed between the penetration seal and the stud, and minimum 100 mm of insulation is provided with the cavity between the penetration seal and the stud. Rigid walls must have a minimum thickness of 75 mm or as otherwise specified and consist of concrete, aerated concrete, or masonry with a minimum density of 650 kg/m³. 	As provided in section 7.
4.		In floor systems: <ul style="list-style-type: none"> Rigid floor thickness must be limited to 150 mm (as tested) and comprise aerated concrete with a minimum density of 650 kg/m³. Applicability of FRLs to thinner concrete slab of minimum thickness of 100 mm. 	As provided in section 7.
5.		The integrity rating achieved for insulated pipes can be applied to uninsulated pipes.	As provided in section 7.

The variations and outcome of this assessment are subject to the limitations and requirements described in sections 2, 3 and 8 of this report. The results of this report are valid until 30 April 2026.

Contents

1.	Introduction	5
2.	Framework for the assessment	5
2.1	Assessment approach	5
2.2	Declaration	6
3.	Limitations of this assessment	6
4.	Description of the specimen and variations	7
4.1	System description	7
4.2	Referenced test data	10
4.3	Variations to the tested systems	11
5.	Applicability of test results in accordance with AS 1530.4:2014	12
5.1	Description of variation	12
5.2	Methodology	12
5.3	Assessment	12
6.	Fire resistance performance of services penetrating Protecta FR Collars	16
6.1	Description of variation	16
6.2	Methodology	16
6.3	Flexible or rigid wall constructions with wall thickness of minimum 75 mm	16
6.4	Flexible or rigid wall constructions with wall thickness of minimum 100 mm	22
6.5	Flexible or rigid wall constructions with wall thickness of minimum 120 mm	46
6.6	Rigid walls constructions with wall thickness of minimum 150 mm	53
6.7	Rigid floor constructions with floor thickness of minimum 150 mm	69
7.	Assessment of specific variations	102
7.1	Description of variation	102
7.2	Methodology	102
7.3	Assessment	102
8.	Validity	105
Appendix A	Drawings and additional information	106
Appendix B	Summary of supporting test data	107

1. Introduction

This report documents the findings of the assessment undertaken to determine the expected fire resistance levels (FRL) of service penetrations protected with Protecta FR Collars if tested in accordance with AS 1530.4:2014¹ and assessed in accordance with AS 4072.1:2005².

This assessment was carried out at the request of Polyseam Ltd. The sponsor details are included in Table 2.

Table 2 Sponsor details

Sponsor	Address
Polyseam Ltd	15 St Andrews Road Huddersfield West Yorkshire HD1 6SB UK

2. Framework for the assessment

2.1 Assessment approach

An assessment is an opinion about the likely performance of a component or element of structure if it was subject to a standard fire test.

No specific framework, methodology, standard or guidance documents exists in Australia for doing these assessments. We have therefore followed the 'Guide to undertaking technical assessments of the fire performance of construction products based on fire test evidence' prepared by the Passive Fire Protection Forum (PFPF) in the UK in 2019³.

This guide provides a framework for undertaking assessments in the absence of specific fire test results. Some areas where assessments may be offered are:

- Where a modification is made to a construction which has already been tested
- The interpolation or extrapolation of results of a series of fire resistance tests, or utilisation of a series of fire test results to evaluate a range of variables in a construction design or a product
- Where, for various reasons – eg size or configuration – it is not possible to subject a construction or a product to a fire test.

Assessments will vary from relatively simple judgements on small changes to a product or construction through to detailed and often complex engineering assessments of large or sophisticated constructions.

This assessment uses established empirical methods and our experience of fire testing similar products to extend the scope of application by determining the limits for the design based on the tested constructions and performances obtained. The assessment is an evaluation of the potential fire resistance performance if the elements were to be tested in accordance with AS 1530.4:2014 and assessed in accordance with AS 4072.1:2005.

This assessment has been written using appropriate test evidence generated at accredited laboratories to the relevant test standard. The supporting test evidence has been deemed appropriate to support the manufacturer's stated design.

¹ Standards Australia, 2014, Methods for fire tests on building materials, components and structures – Part 4: Fire-resistance tests for elements of construction, AS 1530.4:2014, Standards Australia, NSW.

² Standards Australia, 2005, Components for the protection of openings in fire-resistant separating elements: Service penetrations and control joints, AS 4072.1:2005, Standards Australia, NSW.

³ Passive Fire Protection Forum (PFPF), 2019, Guide to undertaking technical assessments of the fire performance of construction products based on fire test evidence, Passive Fire Protection Forum (PFPF), UK.

2.2 Declaration

The 'Guide to undertaking technical assessments of the fire performance of construction products based on fire test evidence' prepared by the PFPF in the UK requires a declaration from the client. By accepting our fee proposal on 2 February 2021, Polyseam Ltd confirmed that:

- To their knowledge the component or element of structure, which is the subject of this assessment, has not been subjected to a fire test to the standard against which this assessment is being made.
- They agree to withdraw this assessment from circulation if the component or element of structure is the subject of a fire test by a test authority in accordance with the standard against which this assessment is being made and the results are not in agreement with this assessment.
- They are not aware of any information that could adversely affect the conclusions of this assessment and – if they subsequently become aware of any such information – they agree to ask the assessing authority to withdraw the assessment.

3. Limitations of this assessment

- The scope of this report is limited to an assessment of the variations to the tested systems described in section 4.3.
- This report details the methods of construction, test conditions and assessed results that are expected if the systems were tested in accordance with AS 1530.4:2014.
- The results of this assessment are applicable to fire exposure from either side for the assessed wall systems and fire exposure from below for the assessed floor systems.
- While it is recommended that for the elastomeric pipe insulation to be classified B-s3 as tested, the achieved results can be extended to cover an insulation material not deemed combustible as determined by AS 1530.1:1994⁴.
- For CLT walls, density must be minimum 510 kg/m³ and the adhesive used must be in the family of heat-resistant melamine-urea-formaldehyde. The outer lamella thicknesses must be equal to or greater than 33 mm.
- For CLT floors, density must be minimum 480 kg/m³ and the adhesive used must be in the family of heat-resistant melamine-urea-formaldehyde. The slab thickness must be minimum 150 mm. The outer lamella thicknesses must be equal to or greater than 30 mm.
- The Protecta FR Collars must be attached with steel screws, anchors or fixings that are suitable for the substrate that the pipe collar is fitted to. For cross-laminated timber wall and floor constructions, the length of the screw/fixing used must be greater than the first lamella thickness to prevent fall-off of the collar during delamination – minimum 80 mm long wood screws in walls, and 100 mm long wood screws in floors. Gaps between pipe and surroundings construction must be sealed with FR Acrylic sealant.
- In systems where insulation installed on metallic and composite pipes is interrupted, it has been established that the insulation does not contribute to the integrity rating of the system. Therefore, assuming insulation is zero, the integrity rating achieved must be maintained when such systems are used on uninsulated pipes.
- Support of services in walls and floors must be maintained as per AS 1530.4:2014 and AS 4072.1:2005 requirements.
- This report is only valid for the assessed systems and must not be used for any other purpose. Any changes with respect to size, construction details, loads, stresses, edge or end conditions – other than those identified in this report – may invalidate the findings of this assessment. If there are changes to the system, a reassessment will need to be done by an Accredited Testing Laboratory (ATL).

⁴ Standards Australia, 1994, Methods for fire tests on building materials, components and structures – Part 1: Combustibility test for materials, AS 1530.1:1994, Standards Australia, NSW.

- The documentation that forms the basis for this report is listed in Appendix A.
- This report has been prepared based on information provided by others. Warringtonfire has not verified the accuracy and/or completeness of that information and will not be responsible for any errors or omissions that may be incorporated into this report as a result.
- This assessment is based on the proposed systems being constructed under comprehensive quality control practices and following appropriate industry regulations and standards on quality of materials, design of structures, guidance on workmanship and the expert handling, placing and finishing of the products on site. These variables are beyond the control and consideration of this report.

4. Description of the specimen and variations

4.1 System description

Protecta FR Collar is a pipe closure device used to form penetration seals where combustible pipes, cables and metal pipes with insulation penetrate walls and floors. The intended use of system Protecta FR Collar is to reinstate the fire resistance performance of flexible wall and rigid wall and floor constructions, where they are penetrated by services.

The Protecta FR Collar is supplied with intumescent liner complete within metal steel shell, to be clamped around the service and screw fixed back to the supporting element. The Protecta FR Collar may be supplied with powder coated steel or stainless-steel shells.

Further, for visual integrity, gaps between pipe and collar may optionally be sealed with a thin bead of FR Acrylic Sealant.

In flexible walls, gaps between the pipe and the construction below 8 mm must have a bead of Protecta FR Acrylic to cover the opening, and for gaps 8 mm or above, the seal must be plugged with FR Acrylic to the full depth of the plasterboards, making up the tested fire resistant wall.

In rigid walls, gaps between the pipe and the construction below 8 mm must have a bead of Protecta FR Acrylic to cover the opening, and for gaps 8 mm or above, the seal must be plugged with 20 mm deep FR Acrylic on 20 mm deep backing of stonewool/rockwool/mineral wool (minimum density 33 kg/m³).

In floors, gaps between the pipe and the construction below 10 mm must have 20 mm deep stonewool to plug the opening, and for gaps 10 mm or above, the seal must be plugged with 10 mm deep FR Acrylic on 40 mm deep backing of stonewool/rockwool/mineral wool (minimum density 33 kg/m³). For collars installed on top side of floors, gaps between the pipe and the top side of the collar must have a bead of Protecta FR Acrylic to cover the opening.

1. The specific elements of construction that the system Protecta FR Collar may be used to provide a penetration seal in, are as follows:
 - a. Flexible walls: The wall must have a minimum thickness of 75 mm and comprise steel studs or timber studs* lined on both faces with minimum 1 layer of 12.5 mm thick plasterboards. Walls are required to be otherwise tested or assessed by others. Apertures are not required to be lined. Wall cavity insulation is optional.

For services tested in walls with two layers of 12.5 mm thick plasterboards, single layer walls are permitted provided that the area around the penetration is built up with an additional layer of fire rated plasterboard. (100 mm × 100 mm from the edge of the aperture).
 - b. Timber walls: The wall must have a minimum thickness of 100 mm and comprise solid wood or cross-laminated timber. Density must be minimum 510 kg/m³ and the adhesive used must be in the family of heat-resistant melamine-urea-formaldehyde. The outer lamella thicknesses must be equal to or greater than 33 mm.
 - c. Rigid walls: The wall must have a minimum thickness of 75 mm and comprise concrete, aerated concrete or masonry, with a minimum density of 650 kg/m³. Wall elements are required to be otherwise tested or assessed by others for the required fire resistance period.

- d. Rigid floors: The floor must have a minimum thickness of 150 mm and comprise aerated concrete or concrete with a minimum density of 650 kg/m³. Floor elements are required to be otherwise tested or assessed by others for the required fire resistance period.

Applicability of FRLs to thinner concrete slab of minimum thickness 100 mm is permissible. Insulation performance of the system will be governed by the concrete slab thickness as stated in AS/NZS 3600:2018⁵. The overall FRL of the system will be governed by the FRL extracted from AS/NZS 3600:2018.

- e. Timber floors: The floor must have a minimum thickness of 150 mm and comprise solid wood or cross-laminated timber. Density must be minimum 480 kg/m³ and the adhesive used must be in the family of heat-resistant melamine-urea-formaldehyde. The slab thickness must be minimum 150 mm. The outer lamella thicknesses must be equal to or greater than 30 mm.

*For timber framed walls no part of the penetration seal may be closer than 100 mm to a stud, the cavity must be closed between the penetration seal and the stud, and minimum 100 mm of insulation confirmed to be deemed non-combustible in accordance with AS 1530.1:1994 must be provided within the cavity between the penetration seal and the stud.

Wall and floor elements are required to be otherwise tested or assessed by others for the required fire resistance period. In cases where the FRL of the wall or floor is less than that of the penetration, the FRL will be derated accordingly.

Protecta Fire Protection Systems which involve services penetrating both sides of a flexible wall may also be used in the situation where the services penetrate one side of the wall only and the remaining side of the wall is not penetrated at the same point (i.e. the services continues on the inside of the wall). All fire integrity and insulation ratings for such single-sided penetrations remain the same as for the equivalent double-sided penetrations for all services except bare metallic pipes. For bare metallic pipes, the thermal insulation ratings will be required to be derated unless a 13 mm or 16 mm baffle system is installed on the unexposed side as per the application.

2. The system Protecta FR Collar may be used to provide a penetration seal with specific supporting constructions and substrates (for details see section 6).

Test results for cables remain valid if the diameter of a single cable is reduced and/or the number of cables in a bunch is reduced provided that the overall diameter of the bunch of any individual cable is not greater than that tested.

The test results obtained with the standard configuration cover all types of insulated cables with copper or aluminium conductors, fibre optic cables and bundled communication cables, except hollow cables.

Results obtained from tests where the supports pass through the seal are applicable to those situations where the support is not continued but not vice versa.

3. The total amount of cross sections of services (including insulation) should not exceed 60% of the penetration area. The test results obtained using standard configuration for cable penetration systems are valid for:
- All type of steel cable trays and ladders
 - Any penetration size equal or smaller than that tested, provided the total amount of cross sections of the cables (core and insulation) does not exceed 60% of the penetration.
4. Support of services in walls and floors must be maintained as per AS 1530.4:2014 and AS 4072.1:2005 requirements.
5. It was confirmed that where PP pipes are mentioned, this includes PP-MV, PP-H, PP-R and similar. Where PE pipes are mentioned, this includes PE-LD, PE-MD, PE-HD, PE-X and similar. The tested PE-HD pipe was confirmed by report sponsor and pipe manufacturer to be

⁵ Standards Australia, 2018, Concrete structures, AS 3600:2018 (Incorporating Amendment No. 1), Standards Australia, NSW.

similar to HDPE pipes. Therefore, the FRLs shown for PE-HD pipes in section 6 are applicable to HDPE, ABS and SAN+PVC plastic pipes.

6. Fire resistance performance for PVC-U pipes used as conduits for cables can be applied to flexible conduits provided that the maximum pipe diameter is 40 mm and the wall thickness ranges between 1.0-3.7 mm.
7. FRLs provided in section 6 for 100 mm thick flexible walls and 150 mm thick rigid floors can be used in timber walls and timber floors (see 4.1.1 for further requirements for timber walls and floors). In timber walls and floors, gaps between the pipe and the construction must be plugged with 25 mm deep Protecta FR Acrylic on 25 mm deep backing of stone-wool on both sides before collars are attached, with minimum 80 mm long wood screws in walls, and 100 mm long wood screws in floors. The minimum annular gap must be 10 mm wide for apertures up to Ø 180 mm in walls and Ø 220 mm in floors. For larger apertures, the annular gap must be 10 mm (± 2 mm).
8. Some of the Protecta FR Collars were tested oversized, i.e. the internal diameter of the collar is larger than the pipe diameter. Protecta FR Collar are oversized to allow for the natural gradient of pipework for flow purposes and inconsistencies of pipe installation. An oversize collar can therefore be used in situations where the penetration size is greater than the pipe diameter and/or where the pipe is inserted at an angle.

Oversize collars can be used as a method of fire protection in both walls and floors for any type of services as assessed in section 6 including both pipes and cables where the requirement for oversize collars arise due to angling of services or oversized apertures. However, when used with over-sized collars, the fire resistance performance of any 180 minutes or 240 minutes systems must be reduced to maximum 120 minutes in integrity and insulation.

The minimum angle tested is 45° as shown in the example in clause 6.5.2 and so this allows the use of over-sized collars for pipes at angles from 90° to 45°. The maximum collar size is 160 mm. The maximum average annular space to be used with over-sized collars is 55 mm.

9. The Protecta FR Collars must be attached with steel screws, anchors or fixings that are suitable for the substrate that the pipe collar is fitted to. For cross-laminated timber wall and floor constructions, the length of the screw/fixing used must be greater than the first lamella thickness to prevent fall-off of the collar during delamination – minimum 80 mm long wood screws in walls, and 100 mm long wood screws in floors.
10. Backing material may be stone wool, rockwool or mineral wool (non-fibre glass) of the specified density and any generic mineral or stone wool product of density of 35 kg/m³ may be installed.
11. In systems where insulation installed on metallic and composite pipes is interrupted, it has been established that the insulation doesn't contribute to the integrity rating of the system. Therefore, assuming insulation is zero, the integrity rating achieved must be maintained when such systems are used on uninsulated pipes.
12. Where single sided top face seals are described in section 6.7.5, these can also be used in composite floors if the thickness of the concrete at the thinnest location is the same or greater than the required depth. Composite floors with equivalent aperture sizes are required to be otherwise tested or assessed by others to achieve a nominated FRL. In cases where the FRL of the floor is less than the penetration protecting the overall system, the FRL will be derated accordingly to match with the FRL of the composite floor.

Refer to section 6 for the assessed FRL given to each construction configuration.

4.2 Referenced test data

The assessment of the variation to the tested system and the determination of the likely performance is based on the results of the fire tests documented in the reports summarised in Table 3. Further details of the tested system are included in Appendix B.

Table 3 Referenced test data

Report number	Test date	Test sponsor	Testing authority	
WF 422787	22 January 2020	Polyseam Ltd	Warringtonfire UK	
WF 423530	29 January 2020			
WF 427717	24 March 2020			
WF 427953	30 March 2020			
WF 427934	14 April 2020			
WF 415582	16 July 2019			
WF 412849	9 April 2019			
WF 19723	25 June 2019		WFRGENT NV, Belgium	
WF 417693	17 September 2019		Warringtonfire UK	
WF 419764	12 December 2019			
WF 394021	8 January 2018			
WF 394948	30 January 2018			
WF 395179	6 February 2018			
WF 396820	28 February 2018			
WF 397678	22 March 2018			
WF 398517	19 April 2018			
WF 394232	11 June 2018			
WF 19221	19 July 2018			WFRGENT NV, Belgium
WF 398928	6 August 2018			Warringtonfire UK
WF 405608	9 October 2018			
WF 19324	31 October 2018	WFRGENT NV, Belgium		
WF 407685	29 November 2018	Warringtonfire UK		
WF 408361	18 December 2018			
WF 380963	6 March 2017			
WF 397686	28 March 2017			
WF 382336	15 June 2017			
WF 384982	29 June 2017			
WF 390800	19 October 2017			
WF 392646	29 November 2017			
WF 372808	12 October 2016			
WF 376483	29 November 2016			

4.3 Variations to the tested systems

We have assessed the systems using baseline test information for similar systems. The variations to the tested systems – together with the referenced standard fire tests – are described in Table 4.

Table 4 Variations to tested system

Item	Reference test	Description	Variations
1.	As given in Appendix B	The referenced tests were conducted to demonstrate how Protecta FR Acrylic sealant is used to reinstate the fire resistance performance of flexible wall, rigid wall and floor constructions when penetrated by various cables, trays and metallic, plastic and composite pipes.	The referenced tests were conducted in accordance with BS EN 1366-3:2009 ⁶ and BS EN 1363-1:2012 ⁷
2.			Assess the likely fire resistance performance of the services if tested in accordance with AS 1530.4:2014 and AS 4072.1:2005.
3.			Assess the performance of various types and sizes of cables, metallic pipes, composite pipes and plastic pipes protected with Protecta FR Acrylic sealant and other supplementary fire sealing systems.
4.			In flexible and rigid wall systems: <ul style="list-style-type: none"> Flexible wall systems must have a minimum thickness of 75 mm and consist of steel or timber studs lined on both faces with 1 layer of minimum 12.5 mm thick fire rated plasterboard. The achieved FRLs are applicable to a flexible wall system with optional insulation and the aperture can optionally be lined. For timber framed walls, it is required that no part of the penetration seal is closer than 100 mm to a stud, the cavity is closed between the penetration seal and the stud, and minimum 100 mm of insulation is provided with the cavity between the penetration seal and the stud. Rigid walls must have a minimum thickness of 75 mm or as otherwise specified and consist of concrete, aerated concrete, or masonry with a minimum density of 650 kg/m³.
5.			In floor systems: <ul style="list-style-type: none"> Rigid floor thickness must be limited to 150 mm (as tested) and comprise aerated concrete with a minimum density of 650 kg/m³. Applicability of FRLs to thinner concrete slab of minimum thickness of 100 mm.
			The integrity rating achieved for insulated pipes can be applied to uninsulated pipes.

⁶ European Committee for Standardization, 2009, Fire resistance tests for service installations. Penetration seals, BS EN 1366-3:2009, European Committee for Standardization, Brussels, Belgium.

⁷ European Committee for Standardization, 2012, Fire resistance tests – General requirements, BS EN 1363-1:2012, European Committee for Standardization, Brussels, Belgium.

5. Applicability of test results in accordance with AS 1530.4:2014

5.1 Description of variation

This assessment report is prepared based on referenced tests provided in Appendix B describing fire resistance testing of fire seals and service penetration protection in various fire separating elements, tested in accordance with BS EN 1363-1:2012, BS EN 1366:3 2009 and BS EN 1366-4:2006. These standards differ from AS 1530.4:2014. The effect these differences have on the fire resistance performance of the test specimens if tested in accordance with AS 1530.4:2014 is discussed below.

5.2 Methodology

The method of assessment used is summarised in Table 5.

Table 5 Method of assessment

Assessment method	
Level of complexity	Complex assessment
Type of assessment	Qualitative / Comparative

5.3 Assessment

5.3.1 Specimen configuration

AS 1530.4:2014 specifies that the service(s) shall be installed so that it projects a minimum 500 mm on each side of the supporting construction, of which at least 200 mm shall extend beyond the extremities of the penetration sealing system. The penetration sealing system shall include any coating, wrapping or other protections to the services. The length of unprotected service on the unexposed face shall not be greater than 500 mm. For plastic pipes, the external projection away from the furnace shall be increased to a minimum of 2000 mm. The measurements shall not include any part of the plug or cap used to seal a pipe within the furnace.

With respect to the pipe end configurations, AS 1530.4:2014 stipulates that services end conditions shall be representative of those intended to be used in practice.

The EN standard stipulates the following field of application based on the tested pipe end configuration:

Table 6 Field of application rules for pipe end configurations

		Tested			
		U/U	C/U	U/C	C/C
Covered	U/U	Y	N	N	N
	C/U	Y	Y	N	N
	U/C	Y	Y	Y	N
	C/C	Y	Y	Y	Y
Y=acceptable, N=not acceptable					

Based on the review of the test data and the above field of application, it is the opinion of this testing authority that services tested with an open/open end fire configuration are considered to be the worst-case scenario as the hot gases will have a clear path to the unexposed side. As a result, the thermocouple placed on the service will likely record the highest temperature when compared to the rest of the pipe end configurations. Therefore, FRL achieved in U/U configuration can be extended to services tested in any of the pipe end configurations.

With respect to the services tested in an open/closed configuration or closed/closed configuration, it is considered that both configurations are not in line with the general requirement of the

AS 1530.4:2014. However, AS 1530.4:2014 stipulates that “service end conditions must be representative of those intended to be used in practice”, therefore, it is reasonable to extend the FRL achieved in both configurations provided that they are representative of the system used in practice.

With respect to the difference in the pipe projection from the wall and the floor system, it is considered that this difference will not likely introduce any detrimental effect to the wall system as the plastic pipe is expected to melt in the first few minutes in a test, and once the sealant is activated, this difference can be negligible.

In case of a floor system, it is argued that having a 2000 mm projection out of the floor slab at the unexposed side may include a detrimental effect due to stack effect but it is also argued that 500 mm projection as stipulated in the BS EN standard could also be considered as the most onerous case as more hot gases are expected to pass from the exposed to the unexposed side at a faster rate, hence increasing the temperature recorded by the T/C placed on the service before the activation and closure of the fire rated sealant. In conclusion, considerable amount of research and test history has showed that the extension of the pipe from the unexposed side will not likely have an impact on the performance of the plastic pipes, hence it can be positively assessed.

5.3.2 Furnace temperature measurement

The furnace thermocouples specified in AS 1530.4:2014 are type K, mineral insulated metal sheathed (MIMS), with a stainless-steel sheath having a wire of diameter of less than 1.0 mm and an overall diameter of 3 mm. The measuring junction protrudes at least 25 mm from the supporting heat resistant tube.

The furnace thermocouples specified in EN 1363-1:2012 are plate thermometers comprised of an assembly of a folded nickel alloy plate, a thermocouple fixed to it and insulation material. A thermocouple is fixed to the side of the plate facing the specimen, with the thermocouple hot junction protected by a pad of insulating material.

The plate is to be constructed from 150 ± 1 mm long by 100 ± 1 mm wide by 0.7 ± 0.1 mm thick austenitic nickel-based superalloy strips.

The measuring junction is to consist of nickel chromium/nickel aluminium (Type K) wire as defined in EN 60584-1, contained within mineral insulation in a heat-resisting steel alloy sheath of nominal diameter 1 mm to 3 mm, with the hot junctions electrically insulated from the sheath.

The thermocouple hot junction is to be fixed to the geometric centre of the plate in the position by a small steel strip made from the same material as the plate. The steel strip can be welded to the plate – or may be screwed to it – to facilitate replacement of the thermocouple. The strip should be approximately 18 mm by 6 mm if it is spot-welded to the plate and nominally 25 mm by 6 mm if it is to be screwed to the plate. The screw is to be 2 mm in diameter.

The assembly of plate and thermocouple should be fitted with a pad of inorganic insulation material 97 ± 1 mm by 97 ± 1 mm by 10 ± 1 mm thick with a density of 280 ± 30 kg/m³.

EN 1363-1:2012 specifies that each plate thermometer shall be at least 100 ± 50 mm from the nearest point of the exposed face of the test construction, whereas AS 1530.4:2014 stipulates a distance of 100 ± 10 mm.

The furnace control thermocouples required by EN 1363-1:2012 are less responsive than those specified by AS 1530.4:2014. This variation in sensitivity can produce a potentially more onerous heating condition for specimens tested to EN 1363-1:2012, particularly when the furnace temperature is changing quickly in the early stages of the test. Furnace temperature regime

The furnace temperature regime for fire resistance tests conducted in accordance with AS1530.4:2014 follows the same trend as EN1363-1:2012.

The parameters outlining the accuracy of control of the furnace temperature in AS 1530.4:2014 and BS EN1363-1:2012 are not appreciably different.

5.3.3 Furnace pressure regime

It is a requirement of both AS 1530.4:2014 and EN 1363-1:2012 that for vertical elements, the furnace shall be operated so that the neutral pressure plane (a pressure of 0 Pa) is established at a height 500 mm above the notional floor level.

For wall penetrations, AS 1530.4:2014 requires that – if the separating element has a height greater than 1 m – it shall be tested with a pressure of 20 ± 3 Pa at the top of the separating element and that the horizontal penetrating services shall be included in the zone where positive pressure exceeds 10 Pa. EN 1366-3:2009 specifies that a minimum pressure of 20 Pa shall be maintained at the top of the uppermost penetration seal in a vertical supporting construction and that services shall only be included in the zone where the positive pressure exceeds 10 Pa.

Therefore, both standards require that a minimum pressure of 10 Pa be maintained at the lowest point of the lowest service.

It is a requirement of both AS 1530.4:2014 and EN 1363-1:2012 that for horizontal elements, a furnace gauge pressure of 20 Pa is established at a height 100 mm below the floor soffit level.

The parameters outlining the accuracy of control of the furnace pressure in AS 1530.4:2014 and EN 1363.1-:2012 are also not appreciably different.

5.3.4 Integrity performance criteria

In accordance with AS 1530.4:2014, while a specimen maintains its insulation performance, the specimen shall be deemed to have failed the integrity criterion if it collapses or sustains flaming on the unexposed face, which can ignite a cotton pad when applied for up to 30 seconds.

A specimen shall be deemed to have failed the integrity criterion in accordance with AS 1530.4:2014 when any of the following occur:

- Sustained flaming for 10 seconds.
- A gap forms that allows the passage of hot gases to the unexposed face and ignites the cotton pad when applied for up to 30 seconds.
- A gap forms that allows the penetration of a 25 mm gap gauge anywhere on the specimen.
- A gap forms that allows a 6 mm × 150 mm gap gauge to penetrate the specimen anywhere on the specimen.

Except for minor variations the integrity criteria in EN 1363.1:1999 are generally applied in a comparable manner. The integrity criteria differ slightly between AS 1530.4:2014 and BS EN 1363-1:2012.

5.3.5 Specimen temperature measurement

The specimen thermocouple specification of service penetrations is generally the same for AS 1530.4:2014 and BS EN 1366-3:2009.

For the penetration construction considered. AS 1530.4:2014 specifies the following locations for thermocouples to be placed.

- At not less than two points approximately 25 mm from the edge of the hole made for the passage of the service (one in uppermost vertical plane).
- On the surface of the penetrating service, at least two thermocouples located approximately 25 mm from the plane of the general surface of the penetrated element (one in uppermost vertical plane).
- At least two positions 25 mm from the interface of the separating element and main penetration seal.

For penetrating sealing systems, BS EN 1363-1:2012 specifies thermocouples are fixed in generally similar locations on the unexposed face: on the supporting construction and/or seal and on the penetrating service adjacent at the plane of penetration, and on the penetrating service some distance from the plane of penetration.

Based on the above, the effect of the differences on the thermocouple locations of the tested construction and the specifications in AS 1530.4:2014 discussed on case-by-case basis.

5.3.6 Insulation performance criteria

The general insulation criteria of AS 1530.4:2014 and BS EN 1363.1:2012 are not appreciably different.

5.3.7 Application of test data to AS 1530.4:2014

The variations in furnace heating regimes, furnace thermocouples and the responses of the different thermocouple types to the furnace conditions are not expected to have a significant effect on the outcome of the referenced fire resistance test.

In the referenced tests, some specimens were not in accordance with AS 1530.4:2014, especially the capping arrangement of pipes. Those services were included in the assessment with the same end conditions as tested.

Based on the above discussion, it is considered that the results relating to the integrity and insulation performance of the referenced tests can be used as a basis to assess the FRL of the specimens if tested in accordance with AS 1530.4:2014.

6. Fire resistance performance of services penetrating Protecta FR Collars

6.1 Description of variation

Various service penetrations, including metal pipes, plastic pipes and cable configurations, are tested protected with Protecta FR collars. Other local protection systems such as Protecta FR Acrylic sealant and service insulation have been tested in combination with Protecta FR collars for integrity and insulation performance.

6.2 Methodology

The method of assessment used is summarised in Table 7.

Table 7 Method of assessment

Assessment method	
Level of complexity	Complex assessment
Type of assessment	Qualitative / Comparative

6.3 Flexible or rigid wall constructions with wall thickness of minimum 75 mm

6.3.1 Penetration seals, in drywalls and concrete/masonry walls

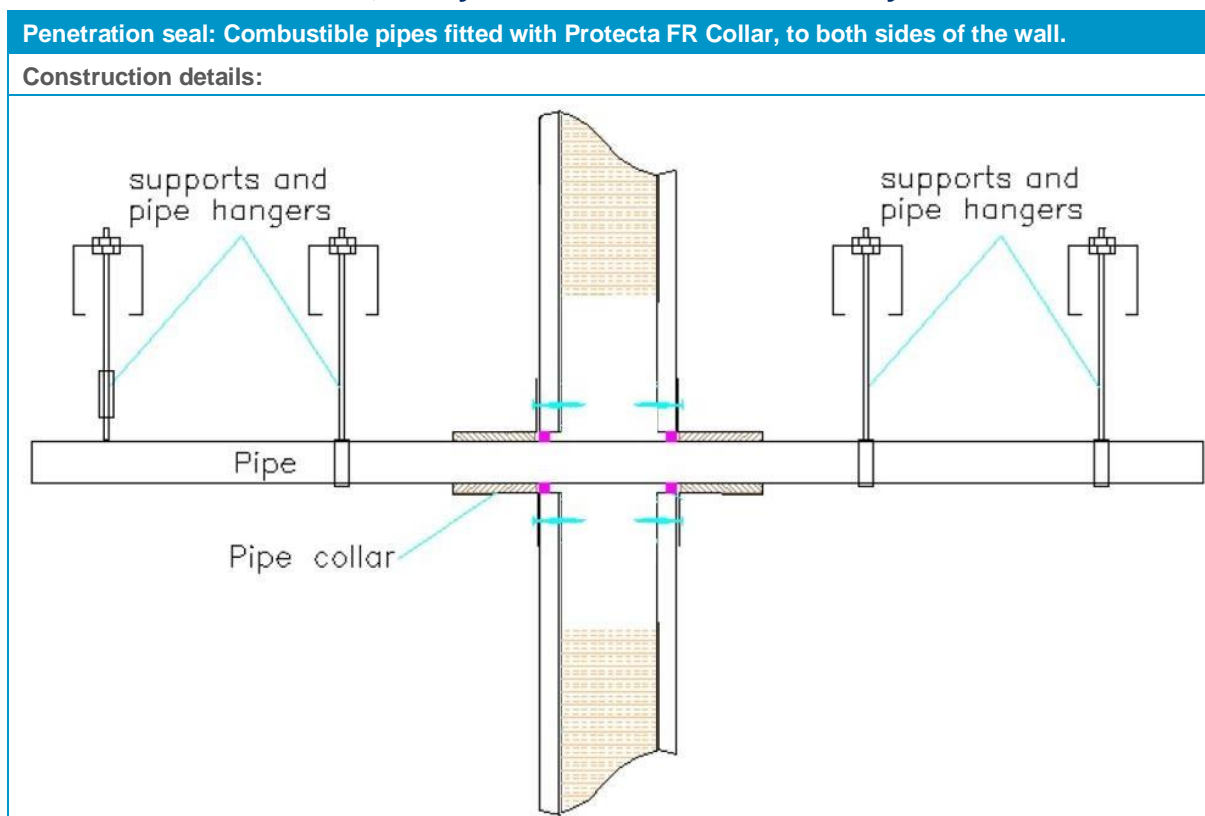

Table 8 PVC-U pipes protected with Protecta FR collar installed at both sides of the wall

Services	Collar Inlay	FRL
PVC-U pipe		
Diameter 32 mm, wall thickness 2.4-4.6 mm	30 × 3.0 mm	-/60/30 U/U, C/U, U/C, C/C
Diameter 40 mm, wall thickness 2.4-4.6 mm		
Diameter 50 mm, wall thickness 2.4-4.6 mm*		
Diameter 55 mm, wall thickness 2.4-4.8 mm*	30 × 3.2 mm	-/60/30 U/C, C/C
Diameter 63 mm, wall thickness 2.5-5.0 mm*	30 × 3.6 mm	
Diameter 75 mm, wall thickness 2.5-5.4 mm*	30 × 4.2 mm	
Diameter 82 mm, wall thickness 2.6-5.6 mm*	30 × 4.6 mm	
Diameter 90 mm, wall thickness 2.6-5.9 mm*	30 × 5.0 mm	
Diameter 110 mm, wall thickness 2.7-6.6 mm*	30 × 6.0 mm	-/60/45 U/C, C/C
Diameter 125 mm, wall thickness 2.9-7.4 mm*	60 × 8.8 mm	
Diameter 140 mm, wall thickness 3.0-8.3 mm*	60 × 11.5 mm	
Diameter 160 mm, wall thickness 3.2-9.5 mm*	60 × 15.0 mm	
*Typical pipe diameters shown, see below graph for intermediate sizes		

PVC Pipes 50-110 / 30 mm Collar - U/C

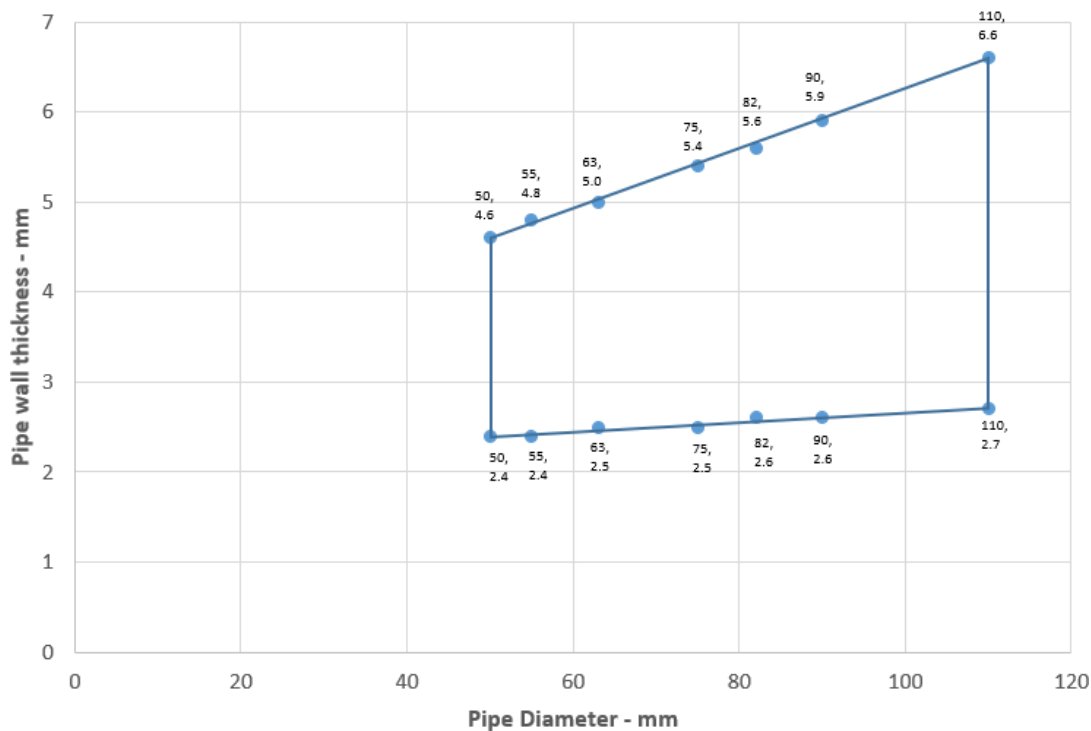

Figure 1 Intermediate pipe wall thicknesses for PVC pipe diameters

PVC Pipes 125-160 / 60 mm Collar - U/C

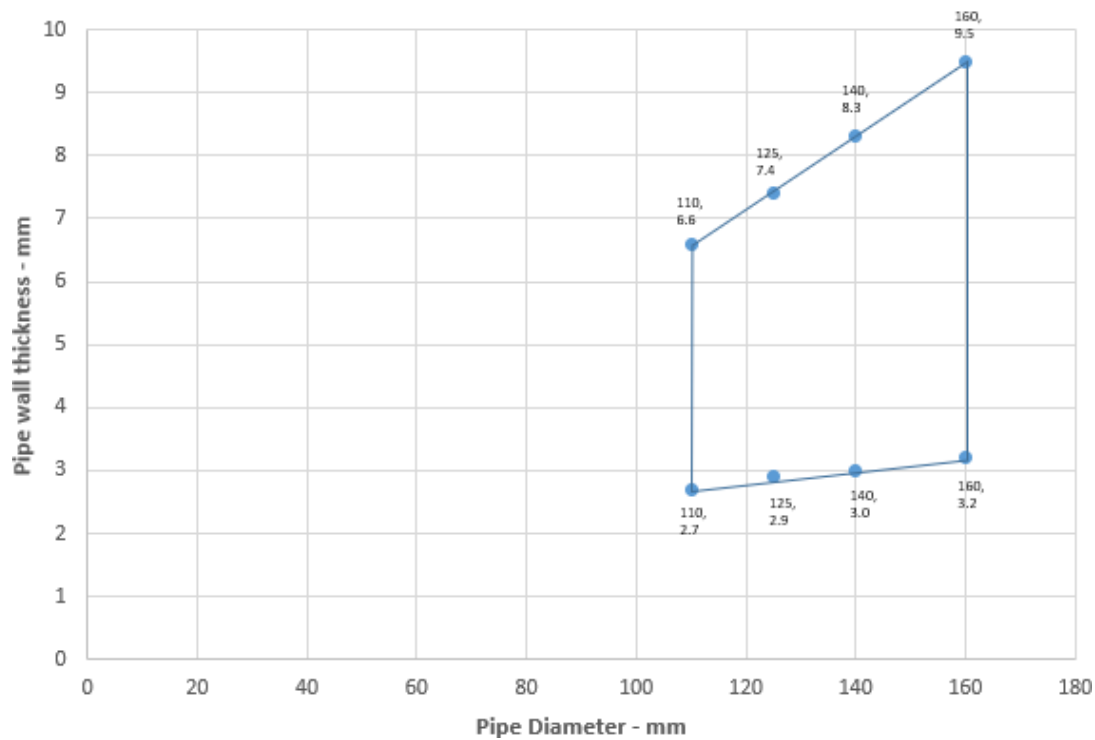

Figure 2 Intermediate pipe wall thicknesses for PVC pipe diameters

Table 9 PE pipes protected with Protecta FR collar installed at both sides of the wall

Services	Collar Inlay	FRL
PE pipe		
Diameter 32 mm, wall thickness 3.0-4.6 mm	30 × 3.0 mm	-/60/30 U/C, C/C
Diameter 40 mm, wall thickness 3.0-4.6 mm		
Diameter 50 mm, wall thickness 3.0-4.6 mm		
Diameter 55 mm, wall thickness 3.0-5.0 mm*		
Diameter 63 mm, wall thickness 3.1-5.8 mm*	30 × 3.6 mm	
Diameter 75 mm, wall thickness 3.2-6.8 mm*	30 × 4.2 mm	
Diameter 82 mm, wall thickness 3.2-7.5 mm*	30 × 4.6 mm	
Diameter 90 mm, wall thickness 3.3-8.2 mm*	30 × 5.0 mm	
Diameter 110 mm, wall thickness 3.4-10.0 mm*	30 × 6.0 mm	-/60/60 U/C, C/C
Diameter 125 mm, wall thickness 4.2-9.8 mm*	60 × 8.8 mm	
Diameter 140 mm, wall thickness 5.1-9.6 mm*	60 × 11.5 mm	
Diameter 160 mm, wall thickness 6.2-9.5 mm*	60 × 15.0 mm	-/60/45 U/C, C/C
*Typical pipe diameters shown, see below graph for intermediate sizes		

PE Pipes 50-110 / 30 mm Collar - U/C

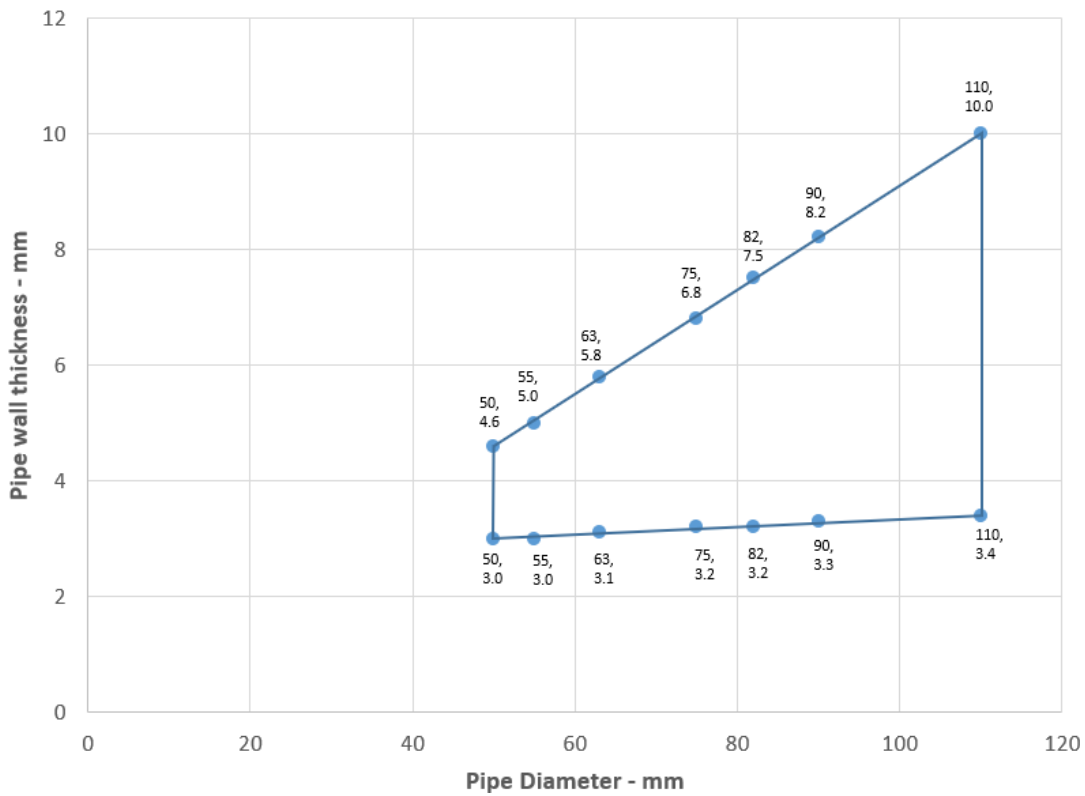

Figure 3 Intermediate pipe wall thicknesses for PE pipe diameters
PE Pipes 125-160 / 60 mm Collar - U/C

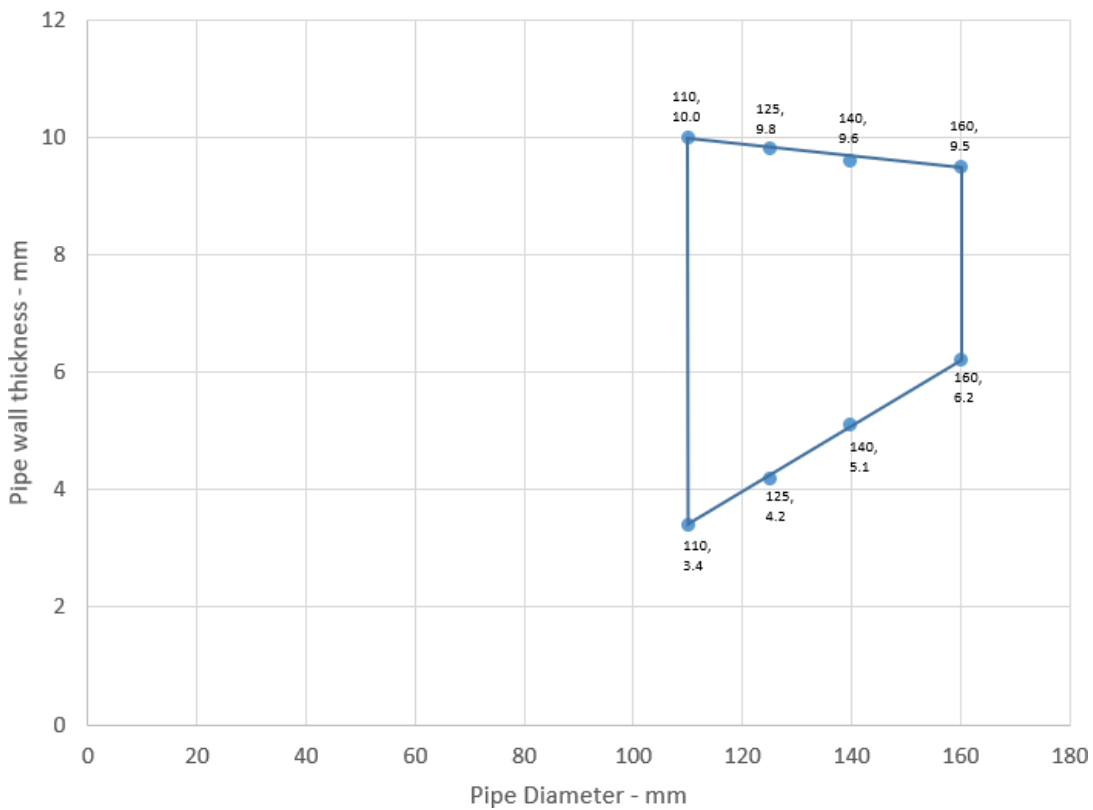

Figure 4 Intermediate pipe wall thicknesses for PE pipe diameters

Table 10 PP pipes protected with Protecta FR collar installed at both sides of the wall

Services	Collar Inlay	FRL
PP pipe		
Diameter 32 mm, wall thickness 2.0-4.6 mm	30 × 3.0 mm	-/60/30 U/U, C/U, U/C, C/C
Diameter 40 mm, wall thickness 2.0-4.6 mm		
Diameter 50 mm, wall thickness 2.0-4.6 mm		
Diameter 55 mm, wall thickness 2.1-5.1 mm*	30 × 3.2 mm	-/60/30 U/C, C/C
Diameter 63 mm, wall thickness 2.3-5.8 mm*	30 × 3.6 mm	
Diameter 75 mm, wall thickness 2.6-6.9 mm*	30 × 4.2 mm	
Diameter 82 mm, wall thickness 2.7-7.5 mm*	30 × 4.6 mm	
Diameter 90 mm, wall thickness 2.9-8.2 mm*	30 × 5.0 mm	
Diameter 110 mm, wall thickness 3.4-10.0 mm*	30 × 6.0 mm	-/60/45 U/C, C/C
Diameter 125 mm, wall thickness 3.9-11.4 mm*	60 × 8.8 mm	
Diameter 140 mm, wall thickness 4.3-12.8 mm*	60 × 11.5 mm	
Diameter 160 mm, wall thickness 4.9-14.6 mm*	60 × 15.0 mm	-/60/60 U/C, C/C
*Typical pipe diameters shown, see below graph for intermediate sizes		

PP Pipes 50-110 / 30 mm Collar

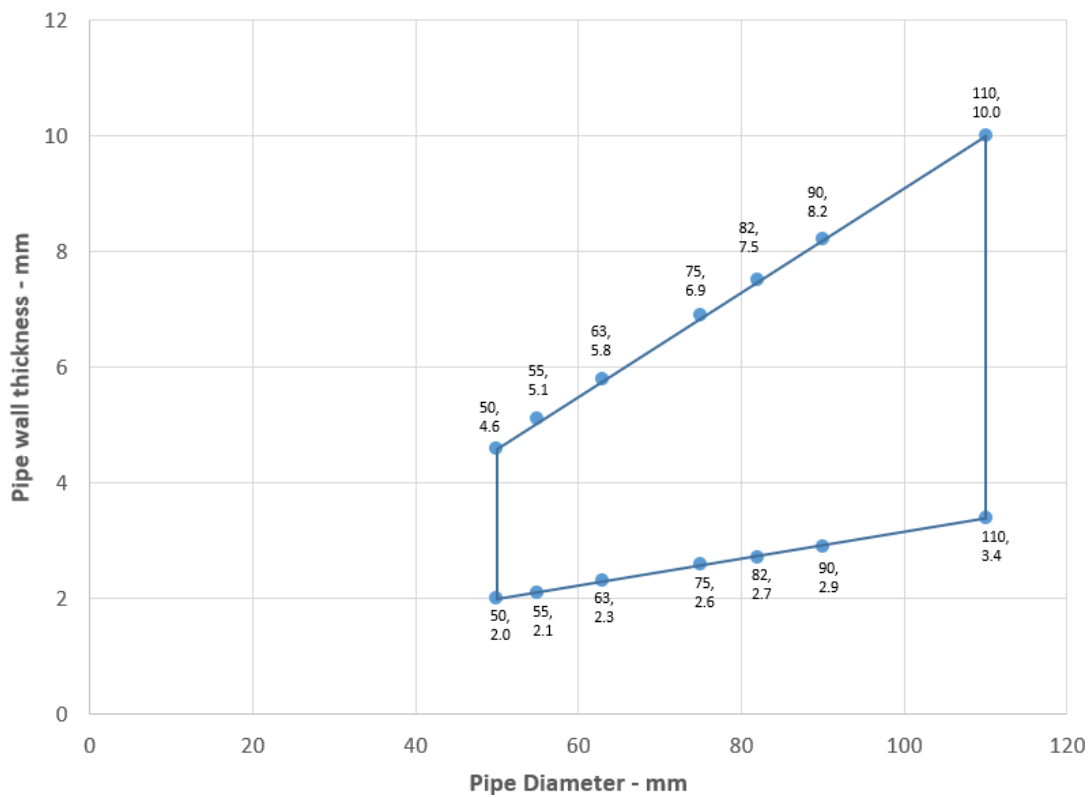

Figure 5 Intermediate pipe wall thicknesses for PP pipe diameters

PP Pipes 125-160 / 60 mm Collar - U/C

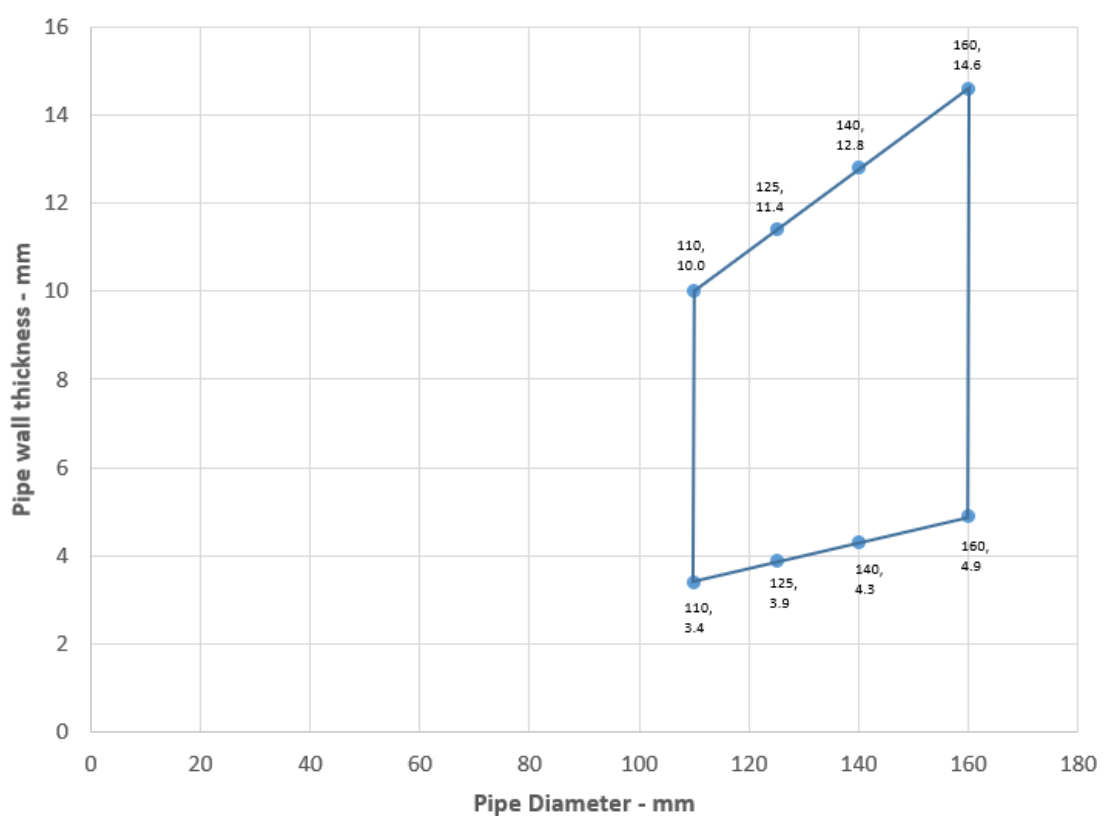

Figure 6 Intermediate pipe wall thicknesses for PP pipe diameters

6.4 Flexible or rigid wall constructions with wall thickness of minimum 100 mm

6.4.1 Penetration seals, in drywalls and concrete/masonry walls

Penetration seal: Combustible pipes fitted with Protecta FR Collar, to both sides of the wall.

Construction details:

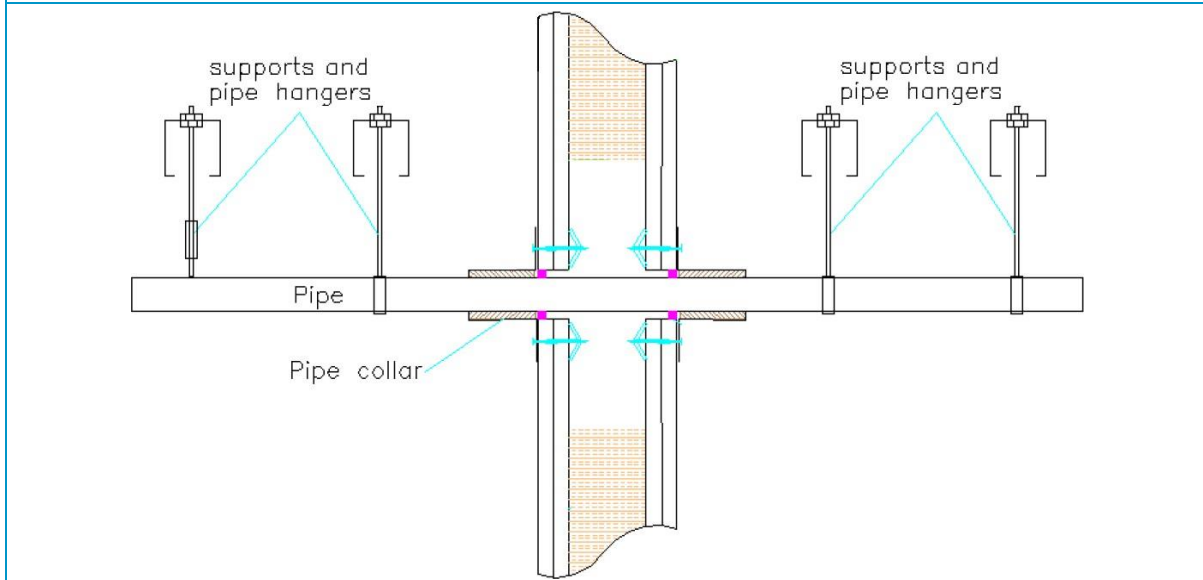

Table 11 PVC-U pipes (diameter 50 – 110 mm) protected with Protecta FR collar installed at both sides of the wall

Services	Collar Inlay	FRL
PVC-U pipe		
Diameter 32 mm, wall thickness 1.2-3.7 mm	30 × 3.0 mm	-/90/60 U/C, C/C
Diameter 40 mm, wall thickness 1.2-3.7 mm		
Diameter 50 mm, wall thickness 1.2-4.6 mm*		
Diameter 55 mm, wall thickness 1.3-4.7 mm*	30 × 3.2 mm	-/60/60 U/C, C/C
Diameter 63 mm, wall thickness 1.5-5.0 mm*	30 × 3.6 mm	
Diameter 75 mm, wall thickness 1.8-5.4 mm*	30 × 4.2 mm	
Diameter 82 mm, wall thickness 2.0-5.6 mm*	30 × 4.6 mm	
Diameter 90 mm, wall thickness 2.2-5.9 mm*	30 × 5.0 mm	
Diameter 110 mm, wall thickness 2.7-6.6 mm*	30 × 6.0 mm	
*Typical pipe diameters shown, see below graph for intermediate sizes		

PVC Pipes 50-110 / 30 mm Collar - U/C

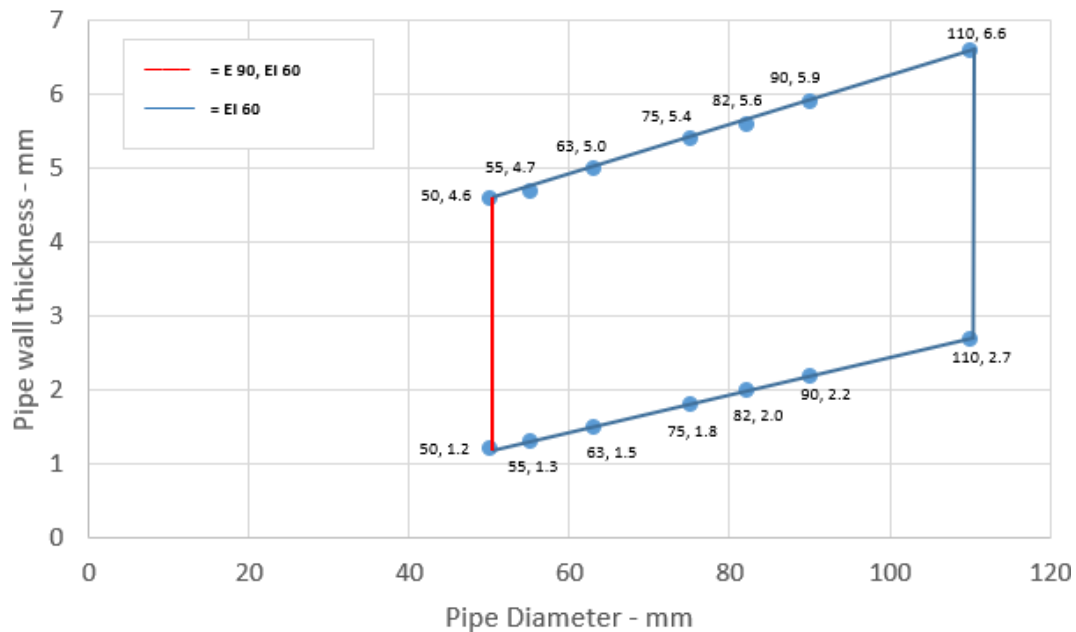

Figure 7 Intermediate pipe wall thicknesses for PVC pipe diameters

Table 12 PVC-U (diameter 110 – 160 mm) pipes protected with Protecta FR collar installed at both sides of the wall

Services	Collar Inlay	FRL
PVC-U pipe		
Diameter 110 mm, wall thickness 2.7-6.6 mm*	50 × 6.0 mm	-/90/60 U/U, C/U, U/C, C/C
Diameter 125 mm, wall thickness 2.9-7.4 mm*	50 × 8.8 mm	
Diameter 140 mm, wall thickness 3.0-8.3 mm*	50 × 11.5 mm	
Diameter 160 mm, wall thickness 3.2-9.5 mm*	50 × 15.0 mm	-/90/90 U/C, C/C
*Typical pipe diameters shown, see below graph for intermediate sizes		

PVC Pipes 110-160 / 50 mm Collar - U/C

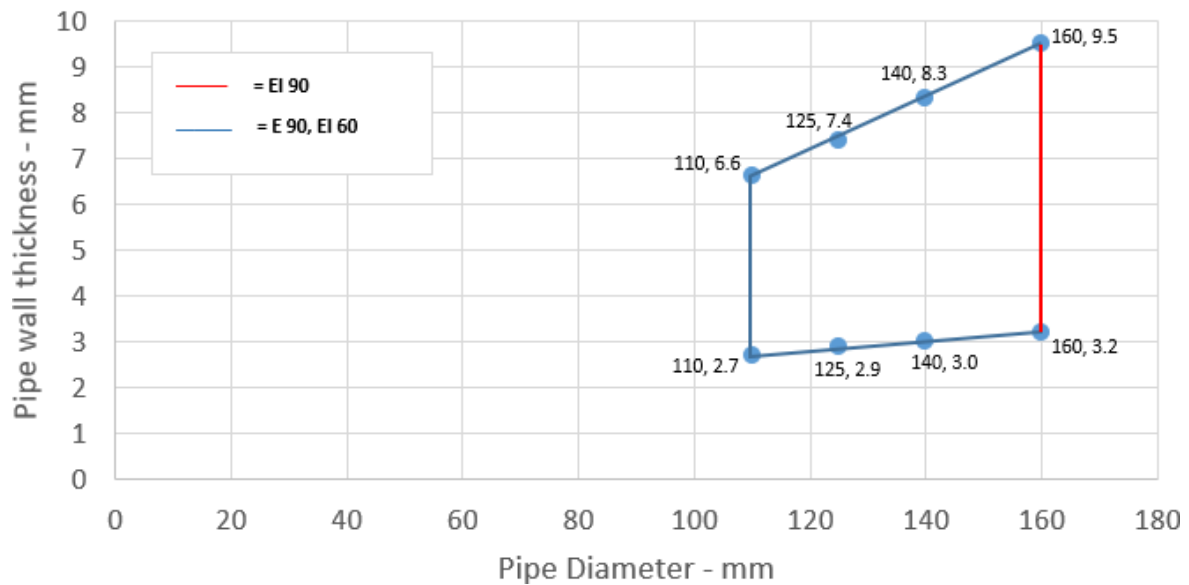

Figure 8 Intermediate pipe wall thicknesses for PVC pipe diameters

Table 13 PVC-U pipes with thicker walls (diameter 32 – 110 mm) protected with Protecta FR collar installed at both sides of the wall

Services	Collar Inlay	FRL
PVC-U pipe		
Diameter 32 mm, wall thickness 2.4-4.6 mm	30 × 3.0 mm	-/90/60 U/U, C/U, U/C, C/C
Diameter 40 mm, wall thickness 2.4-4.6 mm		
Diameter 50 mm, wall thickness 2.4-4.6 mm		
Diameter 55 mm, wall thickness 2.5-4.7 mm*	50 × 3.2 mm	
Diameter 63 mm, wall thickness 2.5-5.0 mm*	50 × 3.6 mm	
Diameter 75 mm, wall thickness 2.6-5.4 mm*	50 × 4.2 mm	
Diameter 82 mm, wall thickness 2.6-5.6 mm*	50 × 4.6 mm	
Diameter 90 mm, wall thickness 2.6-5.9 mm*	50 × 5.0 mm	
Diameter 110 mm, wall thickness 2.7-6.6 mm*	50 × 6.0 mm	
*Typical pipe diameters shown, see below graph for intermediate sizes		

PVC Pipes 50-110 / 50 mm Collar - U/U

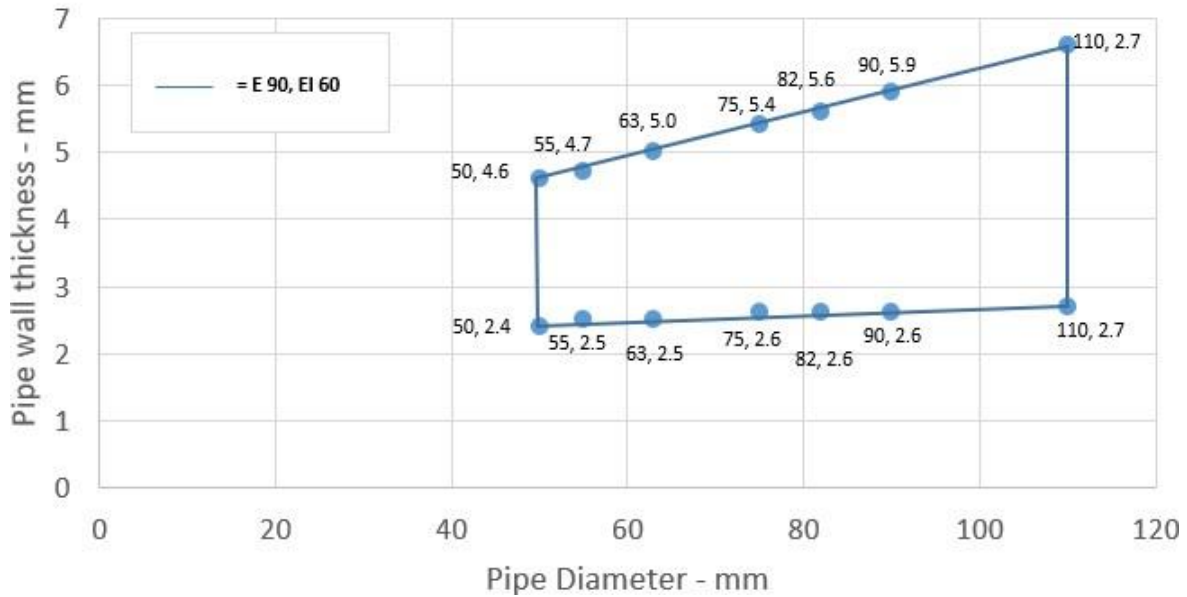

Figure 9 Intermediate pipe wall thicknesses for PVC pipe diameters

Table 14 PVC-U pipes with thicker walls (diameter 110 – 400 mm) protected with Protecta FR collar installed at both sides of the wall

Services	Collar Inlay	FRL
PVC-U pipe		
Diameter 110 mm, wall thickness 2.7-6.6 mm*	60 × 6.0 mm	-/90/60 U/U, C/U, U/C, C/C
Diameter 125 mm, wall thickness 2.9-7.4 mm*	60 × 9.0 mm	-/60/60 U/U, C/U
Diameter 140 mm, wall thickness 3.0-8.3 mm*	60 × 11.5 mm	
Diameter 160 mm, wall thickness 3.2-9.5 mm*	60 × 15.0 mm	
Diameter 200 mm, wall thickness 4.9-11.9 mm*	60 × 18 mm	-/120/120 U/C, C/C
Diameter 315 mm, wall thickness 7.7-12.1 mm*	75 × 30 mm	-/90/90 C/C
Diameter 400 mm, wall thickness 9.8-11.9 mm*	100 × 40 mm	-/120/90 C/C
*Typical pipe diameters shown, see below graph for intermediate sizes		

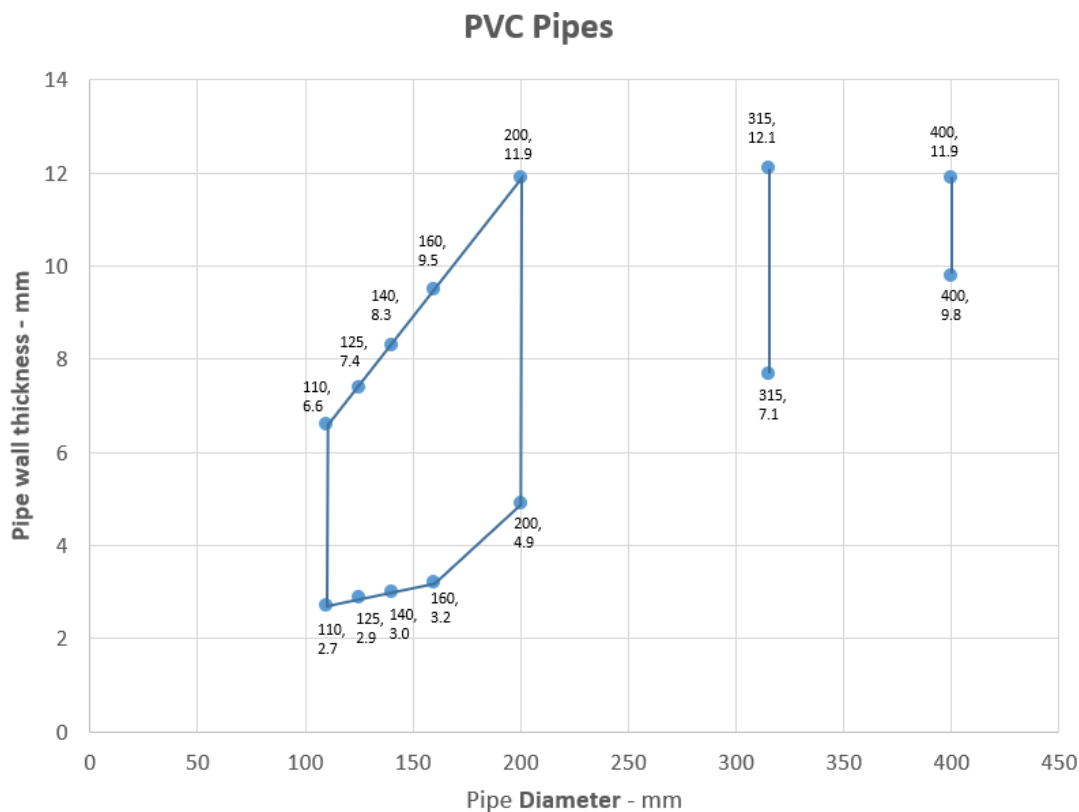

Figure 10 Intermediate pipe wall thicknesses for PVC pipe diameters

Table 15 PE pipes (diameter 32 – 110 mm) protected with Protecta FR collar installed at both sides of the wall

Services	Collar Inlay	FRL
PE pipe		
Diameter 32 mm, wall thickness 3.0-4.6 mm	30 × 3.0 mm	-/90/45 U/U, C/U, U/C, C/C
Diameter 40 mm, wall thickness 3.0-4.6 mm		
Diameter 50 mm, wall thickness 3.0-4.6 mm		
Diameter 32 mm, wall thickness 3.0-5.6 mm	30 × 3.2 mm	-/90/60 U/C, C/C
Diameter 40 mm, wall thickness 3.0-5.6 mm		
Diameter 50 mm, wall thickness 3.0-5.6 mm*		
Diameter 55 mm, wall thickness 3.0-6.0 mm*	30 × 3.2 mm	-/60/60 U/C, C/C
Diameter 63 mm, wall thickness 3.1-6.6 mm*	30 × 3.6 mm	
Diameter 75 mm, wall thickness 3.2-7.5 mm*	30 × 4.2 mm	
Diameter 82 mm, wall thickness 3.2-8.0 mm*	30 × 4.6 mm	
Diameter 90 mm, wall thickness 3.3-8.6 mm*	30 × 5.0 mm	
Diameter 110 mm, wall thickness 3.4-10.0 mm*	30 × 6.0 mm	
*Typical pipe diameters shown, see below graph for intermediate sizes		

PE Pipes 50-110 / 30 mm Collar - U/C

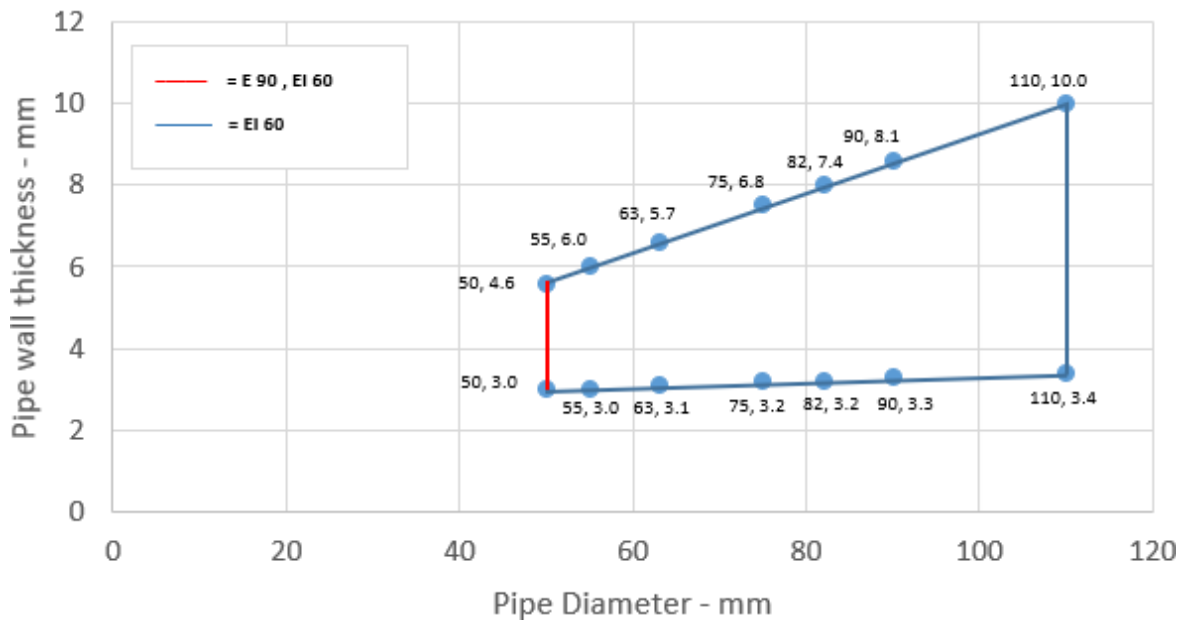

Figure 11 Intermediate pipe wall thicknesses for PE pipe diameters

Table 16 PE pipes (diameter 110 – 160 mm) protected with Protecta FR collar installed at both sides of the wall

Services	Collar Inlay	FRL
PE pipe		
Diameter 110 mm, wall thickness 3.4-10.0 mm*	50 × 6.0 mm	-/90/60 U/U, C/U, U/C, C/C
Diameter 125 mm, wall thickness 4.2-9.8 mm*	50 × 9.0 mm	-/60/60 U/C, C/C
Diameter 140 mm, wall thickness 5.1-9.6 mm*	50 × 11.5 mm	
Diameter 160 mm, wall thickness 6.2-9.5 mm*	50 × 15.0 mm	
*Typical pipe diameters shown, see below graph for intermediate sizes		

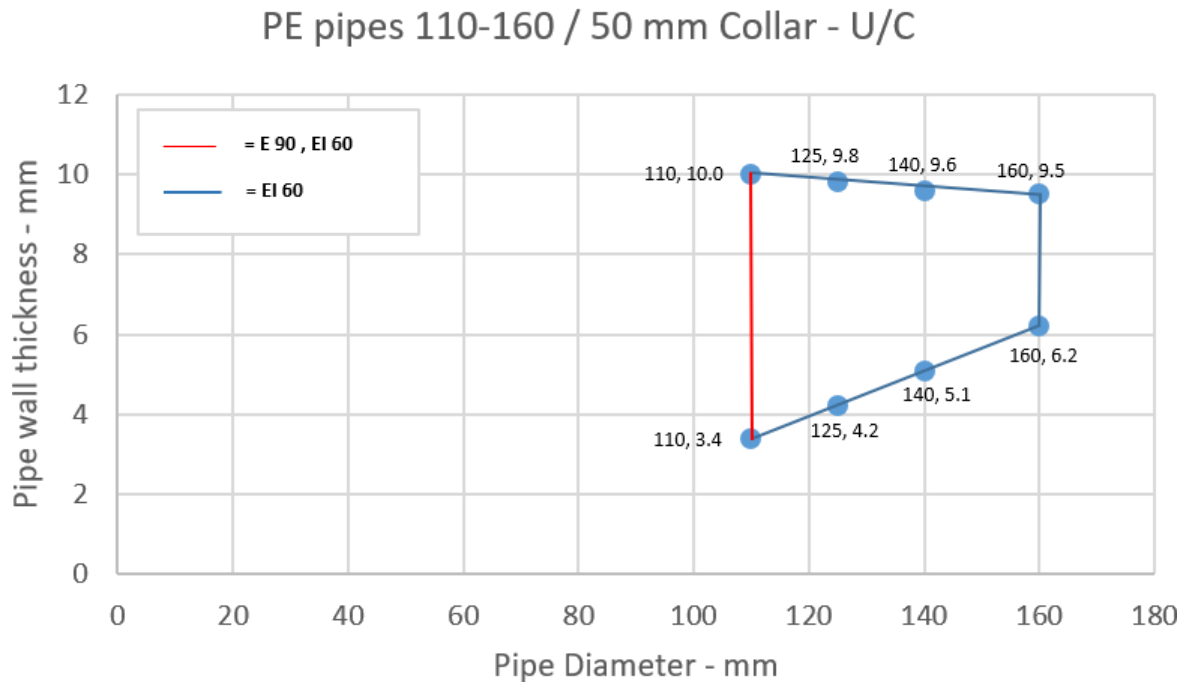

Figure 12 Intermediate pipe wall thicknesses for PE pipe diameters

Table 17 PE pipes (diameter 32 – 110 mm) protected with Protecta FR collar installed at both sides of the wall

Services	Collar Inlay	FRL
PE pipe		
Diameter 32 mm, wall thickness 3.0-4.6 mm	50 × 3.0 mm	-/120/90 U/U
Diameter 40 mm, wall thickness 3.0-4.6 mm		
Diameter 50 mm, wall thickness 3.0-4.6 mm*		
Diameter 55 mm, wall thickness 3.1-5.0 mm*	50 × 3.2 mm	-/90/60 U/U, C/U, U/C, C/C
Diameter 63 mm, wall thickness 3.1-5.7 mm*	50 × 3.6 mm	
Diameter 75 mm, wall thickness 3.2-6.8 mm*	50 × 4.2 mm	
Diameter 82 mm, wall thickness 3.2-7.4 mm*	50 × 4.6 mm	
Diameter 90 mm, wall thickness 3.3-8.1 mm*	50 × 5.0 mm	
Diameter 110 mm, wall thickness 3.4-10.0 mm*	50 × 6.0 mm	
*Typical pipe diameters shown, see below graph for intermediate sizes		

PE Pipes 50-110 / 50 mm Collar - U/U

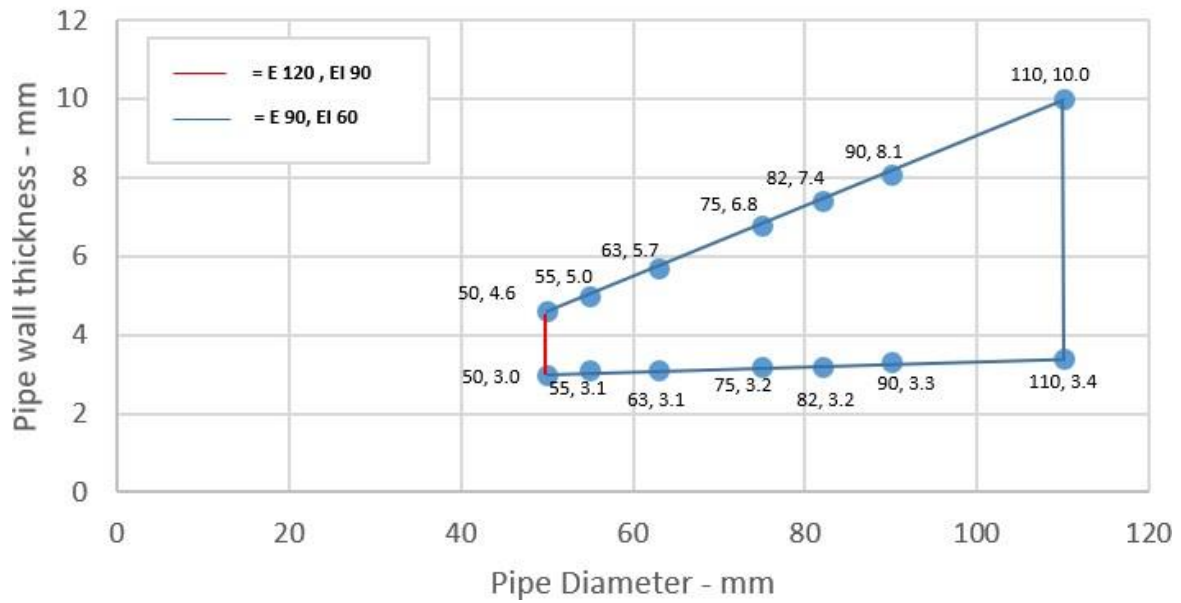

Figure 13 Intermediate pipe wall thicknesses for PE pipe diameters

PE Pipes

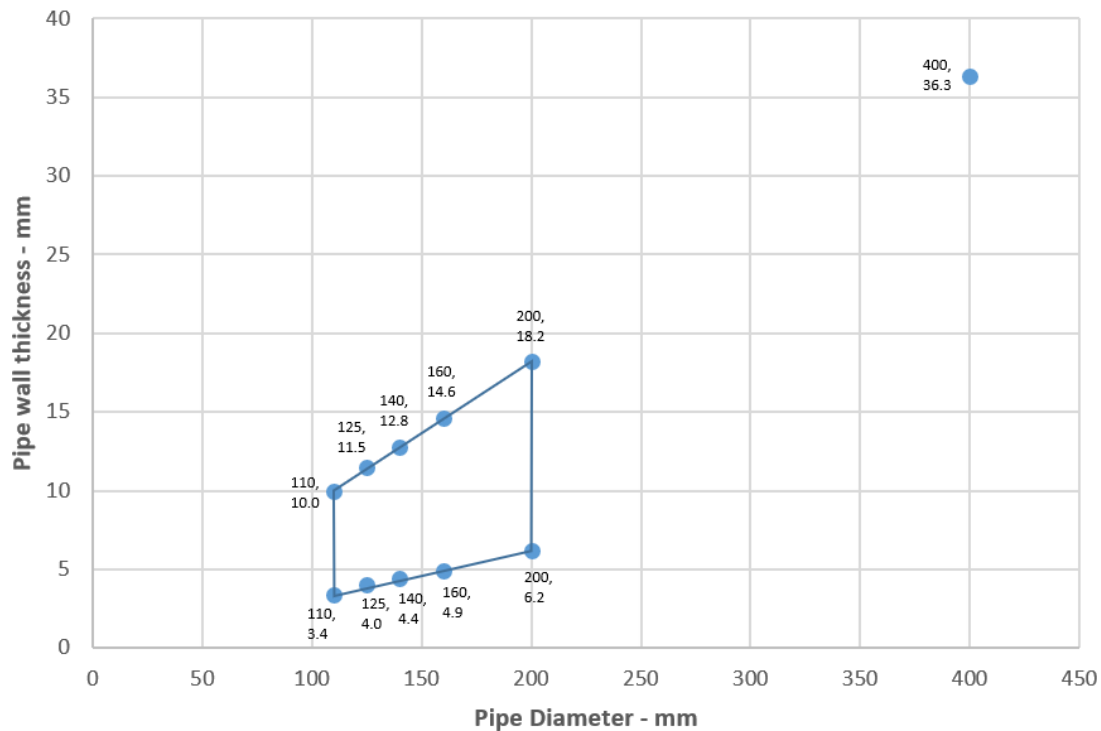

Figure 14 Intermediate pipe wall thicknesses for PE pipe diameters

Table 18 PE pipes (diameter 110 – 160 mm) protected with Protecta FR collar installed at both sides of the wall

Services	Collar Inlay	FRL
PE pipe		
Diameter 110 mm, wall thickness 3.4-10.0 mm*	60 × 6.0 mm	-/90/60 U/U, C/U, U/C, C/C
Diameter 125 mm, wall thickness 4.0-11.5 mm*	60 × 8.8 mm	
Diameter 140 mm, wall thickness 4.4-12.8 mm*	60 × 11.5 mm	
Diameter 160 mm, wall thickness 4.9-14.6 mm*	60 × 15.0 mm	-/90/90 U/U, C/U, U/C, C/C
Diameter 200 mm, wall thickness 6.2-18.2 mm*	60 × 18.0 mm	-/120/90 U/C, C/C
Diameter 400 mm, wall thickness 36.3 mm*	100 × 40.0 mm	-/90/90 C/C
*Typical pipe diameters shown, see below graph for intermediate sizes		

Table 19 PP pipes (diameter 32 – 110 mm) protected with Protecta FR collar installed at both sides of the wall

Services	Collar Inlay	FRL	
PP pipe			
Diameter 32 mm, wall thickness 3.0-5.6 mm	30 × 3.0 mm	-/90/60 U/C, C/C	
Diameter 40 mm, wall thickness 3.0-5.6 mm			
Diameter 50 mm, wall thickness 3.0-5.6 mm			
Diameter 32 mm, wall thickness 1.8-4.6 mm	30 × 3.0 mm	-/90/60 U/U, C/U, U/C, C/C	
Diameter 40 mm, wall thickness 1.8-4.6 mm			
Diameter 50 mm, wall thickness 1.8-4.6 mm			
Diameter 50 mm, wall thickness 1.8-5.6 mm*	30 × 3.0 mm	-/90/60 U/C, C/C	
Diameter 55 mm, wall thickness 2.0-5.7 mm*	30 × 3.2 mm		
Diameter 63 mm, wall thickness 2.2-5.8 mm*	30 × 3.6 mm		
Diameter 75 mm, wall thickness 2.5-5.9 mm*	30 × 4.2 mm		
Diameter 82 mm, wall thickness 2.7-6.0 mm*	30 × 4.6 mm		
Diameter 90 mm, wall thickness 2.9-6.1 mm*	30 × 5.0 mm		
Diameter 110 mm, wall thickness 3.4-6.3 mm*	30 × 6.0 mm		
*Typical pipe diameters shown, see below graph for intermediate sizes			

PP Pipes 50-110 / 30 mm Collar - U/C

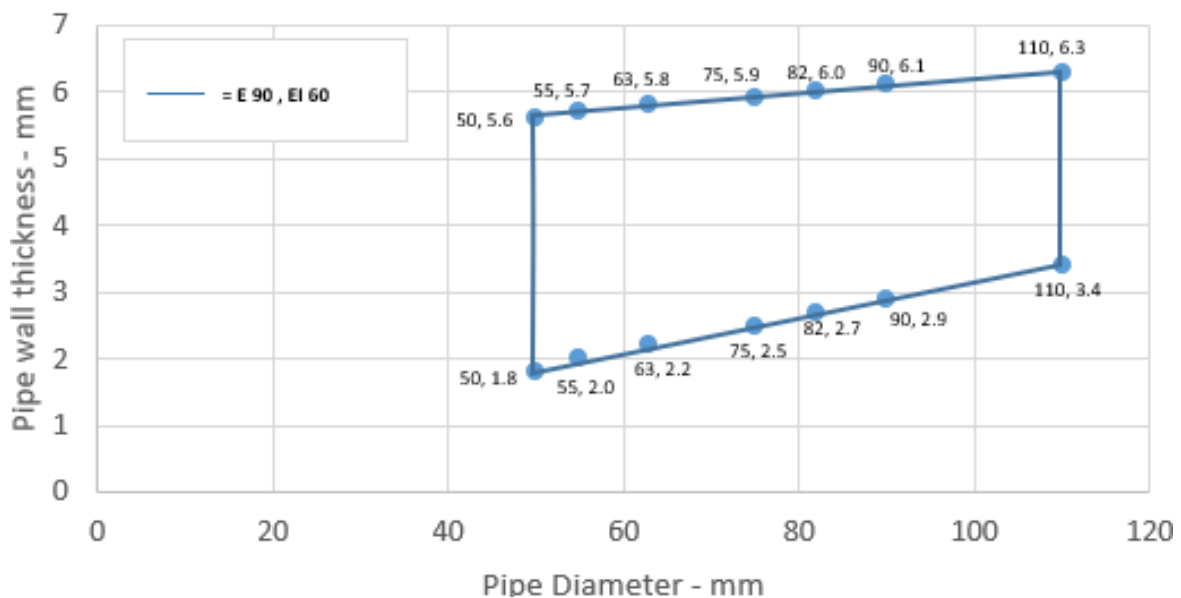

Figure 15 Intermediate pipe wall thicknesses for PP pipe diameters

Table 20 PP pipes (diameter 50 – 160 mm) protected with Protecta FR collar installed at both sides of the wall

Services	Collar Inlay	FRL
PP pipe		
Diameter 50 mm, wall thickness 1.8-5.6 mm*	50 × 3.0 mm	-/90/60 U/C, C/C
Diameter 55 mm, wall thickness 2.0-6.0 mm*	50 × 3.2 mm	
Diameter 63 mm, wall thickness 2.2-6.6 mm*	50 × 3.6 mm	
Diameter 75 mm, wall thickness 2.5-7.6 mm*	50 × 4.2 mm	
Diameter 82 mm, wall thickness 2.7-8.2 mm*	50 × 4.6 mm	
Diameter 90 mm, wall thickness 2.9-8.9 mm*	50 × 5.0 mm	
Diameter 110 mm, wall thickness 3.4-10.5 mm*	50 × 6.0 mm	
Diameter 125 mm, wall thickness 3.8-11.7 mm*	50 × 8.8 mm	
Diameter 140 mm, wall thickness 4.2-12.9 mm*	50 × 11.5 mm	
Diameter 160 mm, wall thickness 4.9-14.6 mm*	50 × 15.0 mm	

*Typical pipe diameters shown, see below graph for intermediate sizes

PP Pipes 50-160 / 50 mm Collar - U/C

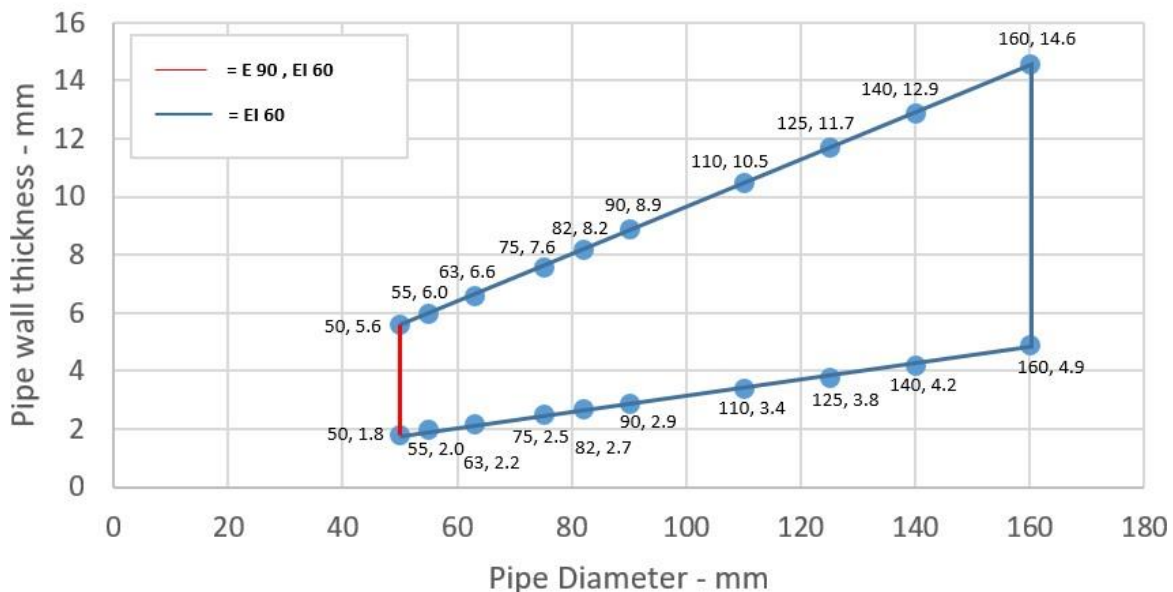

Figure 16 Intermediate pipe wall thicknesses for PP pipe diameters

Table 21 PP pipes (diameter 50 – 110 mm) protected with Protecta FR collar installed at both sides of the wall

Services	Collar inlay	FRL
PP pipe		
Diameter 50 mm, wall thickness 1.8-4.6 mm*	50 × 3.0 mm	-/90/60 U/U, C/U, U/C, C/C
Diameter 55 mm, wall thickness 2.0-4.7 mm*	50 × 3.2 mm	
Diameter 63 mm, wall thickness 2.2-5.0 mm*	50 × 3.6 mm	
Diameter 75 mm, wall thickness 2.5-5.4 mm*	50 × 4.2 mm	
Diameter 82 mm, wall thickness 2.7-5.6 mm*	50 × 4.6 mm	
Diameter 90 mm, wall thickness 2.9-5.9 mm*	50 × 5.0 mm	
Diameter 110 mm, wall thickness 3.4-6.6 mm*	50 × 6.0 mm	
*Typical pipe diameters shown, see below graph for intermediate sizes		

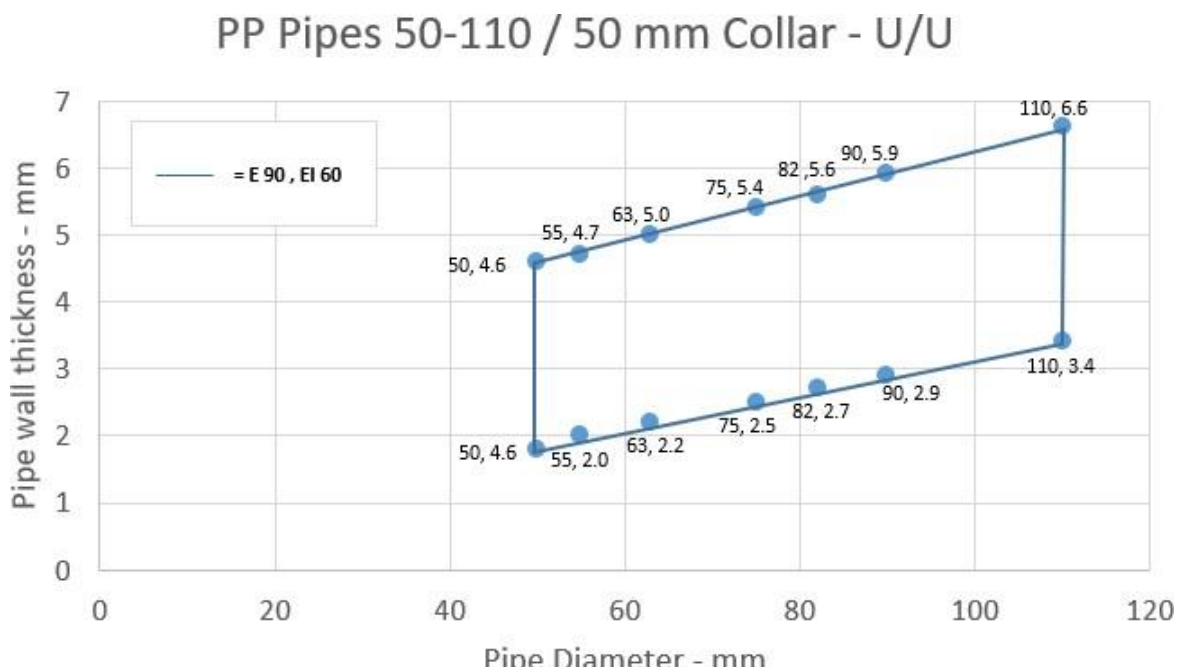

Figure 17 Intermediate pipe wall thicknesses for PP pipe diameters

Table 22 PP pipes (diameter 110 – 400 mm) protected with Protecta FR collar installed at both sides of the wall

Services	Collar Inlay	FRL
PP pipe		
Diameter 110 mm, wall thickness 3.4-6.6 mm*	60 × 6.0 mm	-/90/60 U/U, C/U, U/C, C/C
Diameter 125 mm, wall thickness 3.9-9.0 mm*	60 × 9.0 mm	
Diameter 140 mm, wall thickness 4.4-11.4 mm*	60 × 11.5 mm	
Diameter 160 mm, wall thickness 4.9-14.6 mm*	60 × 15.0 mm	
Diameter 200 mm, wall thickness 4.9-18.2 mm*	60 × 18.0 mm	-/120/90 U/C, C/C
Diameter 400 mm, wall thickness 22.7 mm*	100 × 40.0 mm	-/60/60 C/C

*Typical pipe diameters shown, see below graph for intermediate sizes

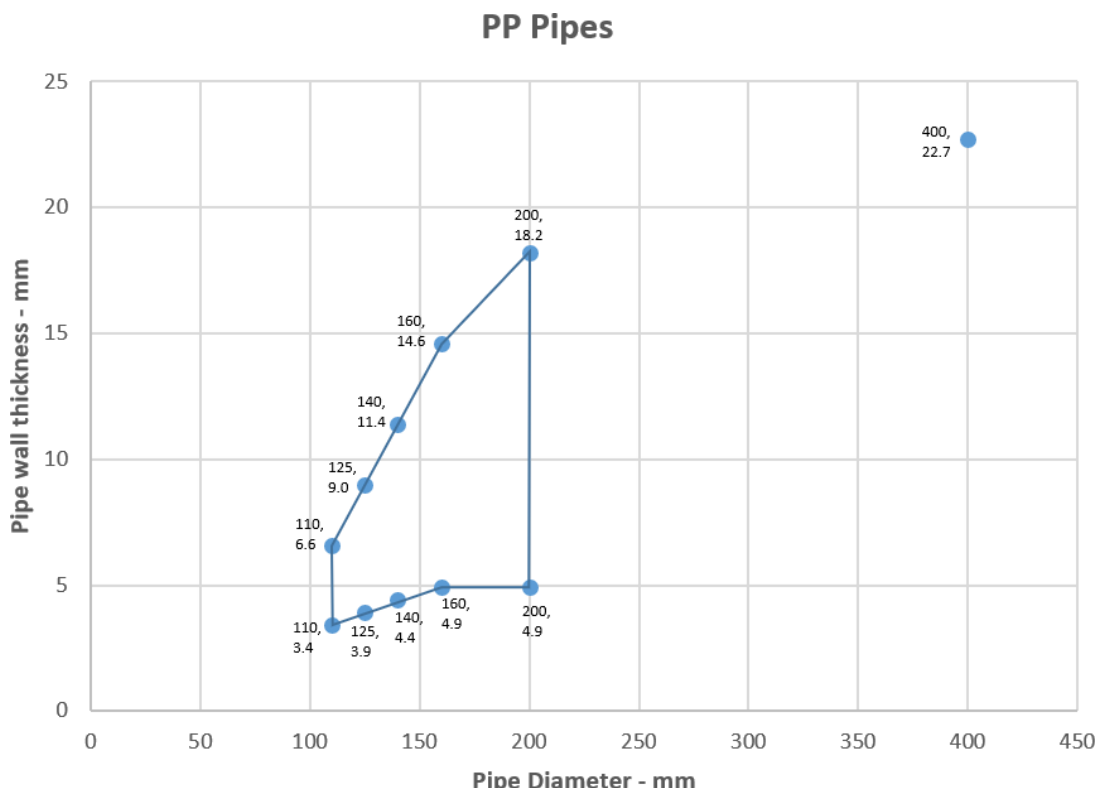

Figure 18 Intermediate pipe wall thicknesses for PP pipe diameters

Table 23 Pipes protected with Protecta FR collar installed at both sides of the wall

Services	Collar Inlay	FRL
Wavin SiTech + PP-M B		
32-40 mm diameter/ 1.8 mm wall thickness	50 × 3.0 mm	-/120/120 U/U
50 mm diameter/ 1.8 mm wall thickness	50 × 3.2 mm	
75 mm diameter/ 1.8-2.5 mm wall thickness	50 × 4.2 mm	-/120/60 U/U
90 mm diameter/ 1.8-2.9 mm wall thickness	50 × 5.0 mm	
110 mm diameter/ 1.8-3.4 mm wall thickness	50 × 6.0 mm	
Aquatherm Green SDR9 MF PP-RP		
32 mm diameter/3.0-5.6 mm wall thickness	30 × 3.0 mm	-/120/120 C/C
40 mm diameter/3.0-5.6 mm wall thickness	50 × 3.0 mm	
50 mm diameter/3.0-5.6 mm wall thickness	50 × 3.2 mm	
63 diameter/3.6-7.0 mm wall thickness	50 × 3.6 mm	-/120/60 C/C
75 diameter/4.1-8.4 mm wall thickness	50 × 4.2 mm	
90 diameter/4.7-10.1 mm wall thickness	50 × 5.0 mm	
110 diameter/5.6-12.3 mm wall thickness	50 × 6.0 mm	
Geberit Silent PP		
32-50 mm diameter/ 1.8 mm wall thickness	50 × 3.0 mm	-/120/120 U/U
75 mm diameter/1.8-2.5 mm wall thickness	50 × 4.2 mm	-/120/60 U/U
90 mm diameter/1.8-2.9 mm wall thickness	50 × 5.0 mm	
110 mm diameter/1.8-3.4 mm wall thickness	50 × 6.0 mm	
Polo-Kal NG Poloplast PP-MV		
32-40 mm diameter/1.8-2.0 mm wall thickness	50 × 3.0 mm	-/120/120 U/U
50 mm diameter/1.8-2.0 mm wall thickness	50 × 3.2 mm	
75 mm diameter/1.9-2.6 mm wall thickness	50 × 4.2 mm	-/120/90 U/U
90 mm diameter/1.9-2.9 mm wall thickness	50 × 5.0 mm	
110 mm diameter/2.0-3.4 wall thickness	50 × 6.0 mm	
Diameter 125 mm, wall thickness 3.9 mm	60 × 9.0 mm	-/120/- U/U, -/120/120 U/C
Diameter 160 mm, wall thickness 4.9 mm	60 × 15 mm	-/120/120 U/U
Rehau Raupiano Plus PP-DD		
40 mm diameter/1.8 mm wall thickness	50 × 3.0 mm	-/120/90 U/U
50 mm diameter/1.8 mm wall thickness	50 × 3.2 mm	
75 mm diameter/1.8-2.2 mm wall thickness	50 × 4.2 mm	-/120/60 U/U
90 mm diameter/1.8-2.4 mm wall thickness	50 × 5.0 mm	
110 mm diameter/1.8-2.7 mm wall thickness	50 × 6.0 mm	
Diameter 125 mm, wall thickness 3.1 mm	60 × 9.0 mm	-/120/120 U/U
Diameter 160 mm, wall thickness 3.9 mm	60 × 15.0 mm	

Services	Collar Inlay	FRL
BluePower Multilayer pipe – TR02-PP		
32-40 mm diameter/1.8 mm wall thickness	50 × 3.0 mm	-/120/90 U/U
50 mm diameter/1.8 mm wall thickness	50 × 3.2 mm	
75 mm diameter/1.8-2.5 mm wall thickness	50 × 4.2 mm	-/120/60 C/U
90 mm diameter/1.8-2.9 mm wall thickness	50 × 5.0 mm	
110 mm diameter/1.8-3.4 mm wall thickness	50 × 6.0 mm	
125 mm diameter/2.3-3.8 mm wall thickness	60 × 9.0 mm	-/-/60 C/U
160 mm diameter/3.4-4.9 mm wall thickness	60 × 15.0 mm	-/-/90 C/U
Uponor Decibel		
50 mm diameter/ 2.0 mm wall thickness	50 × 3.0 mm	-/120/60 U/U
75 mm diameter/ 2.6 mm wall thickness	50 × 4.2 mm	
110 mm diameter/ 3.8 mm wall thickness	50 × 6.0 mm	
*Typical pipe diameters shown, see below graph for intermediate sizes		

6.4.2 Penetration seals, in drywalls and concrete/masonry walls

Penetration seal: Cables and pipes fitted with Protecta FR Collar, to both sides of the wall.

Construction details:

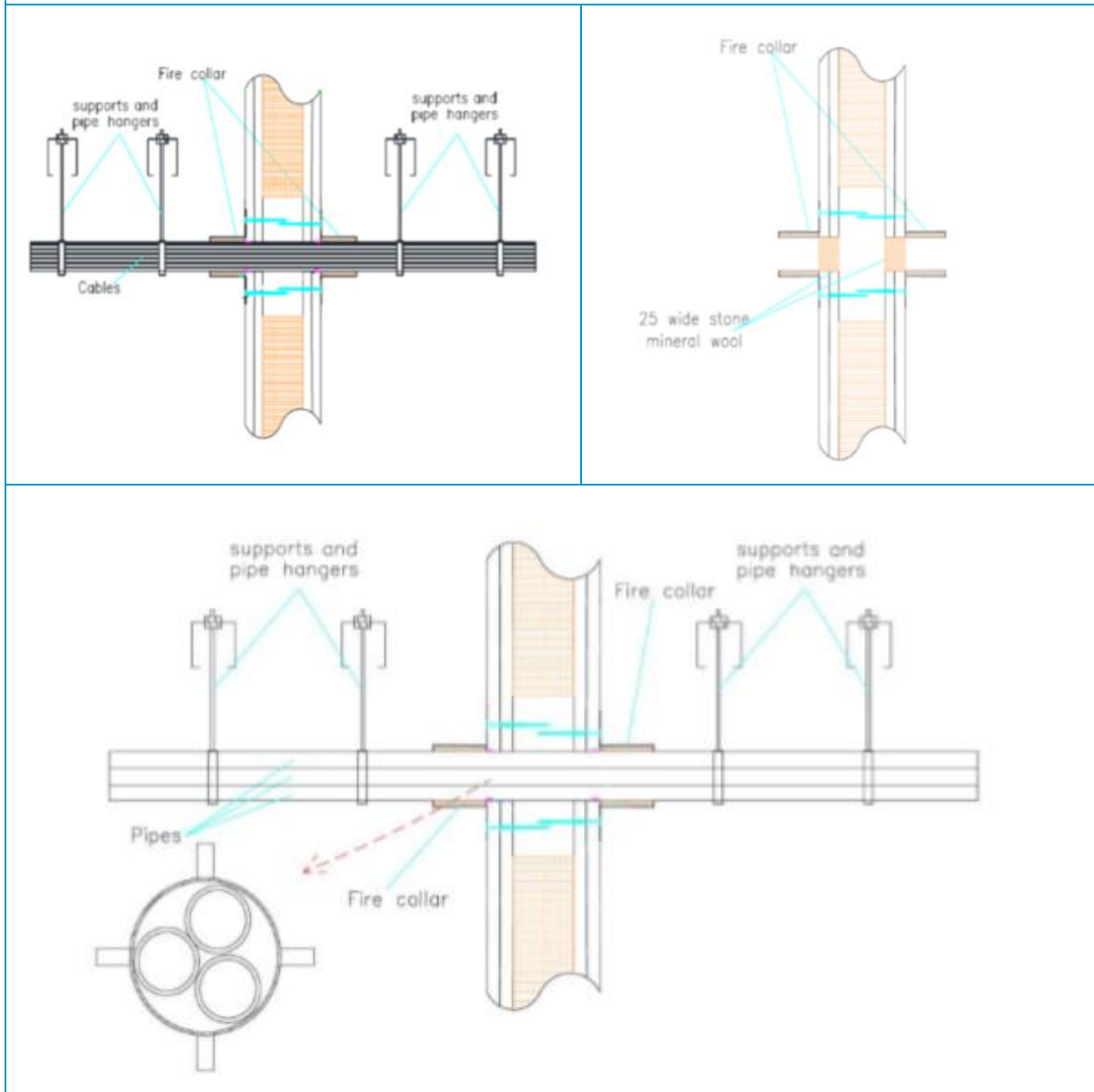

Table 24 Cables and pipes protected with Protecta FR collar on both sides

Services	Collar	Collar inlay	FRL
Cables up to Ø 21 mm, in partial or fully filled tied bundles up to Ø 110 mm (Collar internal diameter to match cable bundle size).	Up to 110 mm collar at 30 mm height	Between 3.0 and 6.0 mm	-/120/60
Cables up to Ø 80 mm, in partial or fully filled tied bundles up to Ø 160 mm (Collar internal diameter to match cable bundle size).	Up to 110 mm collar at 50 mm height, 125-160 mm at 60 mm height	Between 3.0 and 15.0 mm	-/120/60
PVC pipes up to Ø 40 mm, wall thickness 1.0-3.7 mm with or without cables up to Ø 21 mm, in partial or fully filled pipe bundles up to Ø 160 mm.	Up to 110 mm collar at 50 mm height, 125-160 mm at 60 mm height	Between 3.0 and 15.0 mm	-/90/90 U/C

Services	Collar	Collar inlay	FRL
PE pipes up to Ø 40 mm, wall thickness 2.0-3.7 mm with or without cables up to Ø 21 mm, in partial or fully filled pipe bundles up to Ø 160 mm			
PP pipes up to Ø 40 mm, wall thickness 1.8-3.7 mm with or without cables up to Ø 21 mm, in partial or fully filled pipe bundles up to Ø 160 mm.			
None (blank). Hole behind collar to be fitted with minimum 25 mm thick stone mineral wool insulation at minimum 33 kg/m ³ .	Up to 110 mm collar at 30 mm height	Between 3.0 and 6.0 mm	-/120/60
None (blank). Hole behind collar to be fitted with minimum 25 mm thick stone mineral wool insulation at minimum 33 kg/m ³ .	160 mm collar at 60 mm height	15.0 mm	-/120/120
Uponor Aqua PEX pipe in pipe system			
Diameter up to 25 mm pipes, wall thickness 0.6 mm, in bundles up to 55 mm	55 mm collar at 30 mm height	3.2 mm	-/120/90 C/C
*PVC, PE and PP pipes can be mixed in the same bundle.			

6.4.3 Penetration seals, in drywalls and concrete/masonry walls

Penetration seal: CS (Continuous Sustained) insulated metallic pipes fitted with Protecta FR Collar, to both sides of the wall.

Construction details:

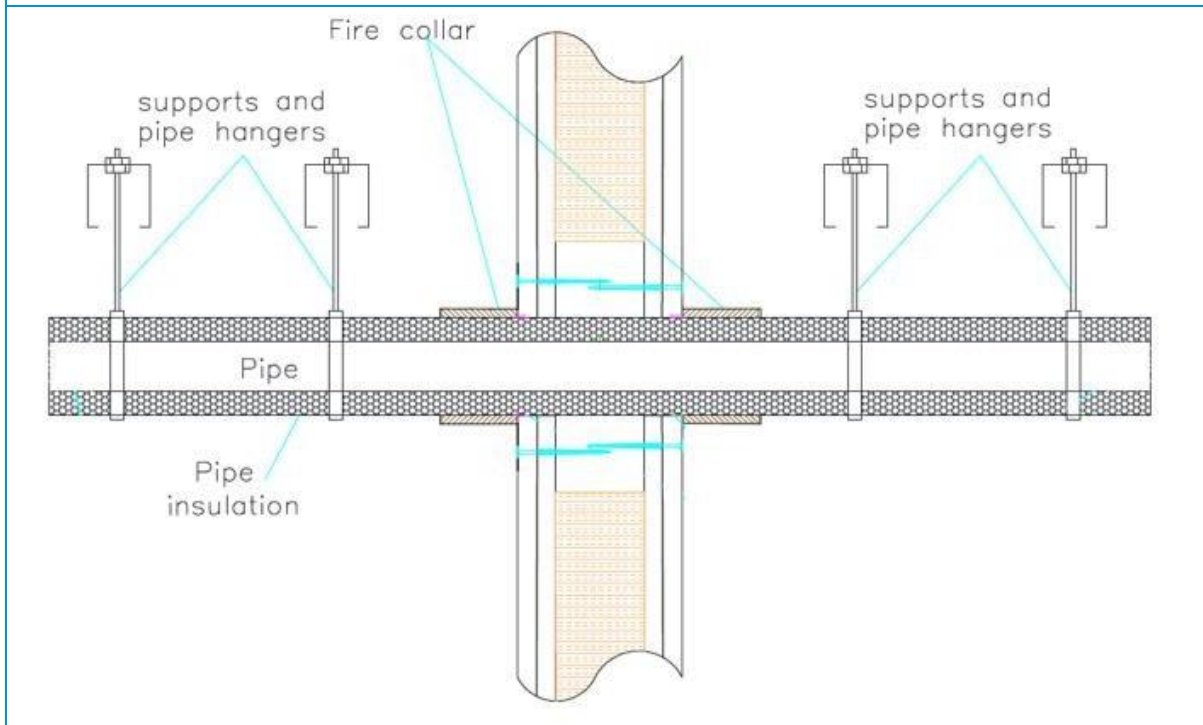

Table 25 Insulated metallic pipes protected with Protecta FR collar on both sides

Services	Insulation	Collar	FRL
Copper pipe or mild steel*			
Maximum diameter 54 mm, wall thickness 0.7-14.2 mm*	9-50 mm thick Elastomeric insulation minimum class B-s3, d0	Up to 110 mm collar at 50 mm height, 125-160 mm at 60 mm height	-/90/60 C/C
Diameter 54 mm, wall thickness 1.2 mm	25 mm thick Phenolic Foam insulation	Ø 110 × 50 × 6.0 mm	-/120/60 C/C
Diameter 54 mm, wall thickness 1.2 mm	20 mm thick PE foam insulation	Ø 110 × 50 × 6.0 mm	-/120/90 C/C
Alupex pipe			
Maximum diameter 75 mm, wall thickness 2.25-4.6 mm*	9-50 mm thick Elastomeric insulation minimum class B-s3, d0	Up to 110 mm collar at 50 mm height, 125-200 mm at 60 mm height	-/90/60 C/C
* Typical pipe diameters shown, see below graphs for intermediate sizes			
+The integrity performances listed can be applied to bare metallic pipes (copper or steel). However, no insulation performance will be given.			

Copper or Steel Pipes 32-54 / 9-50 mm Elastomeric Insulation

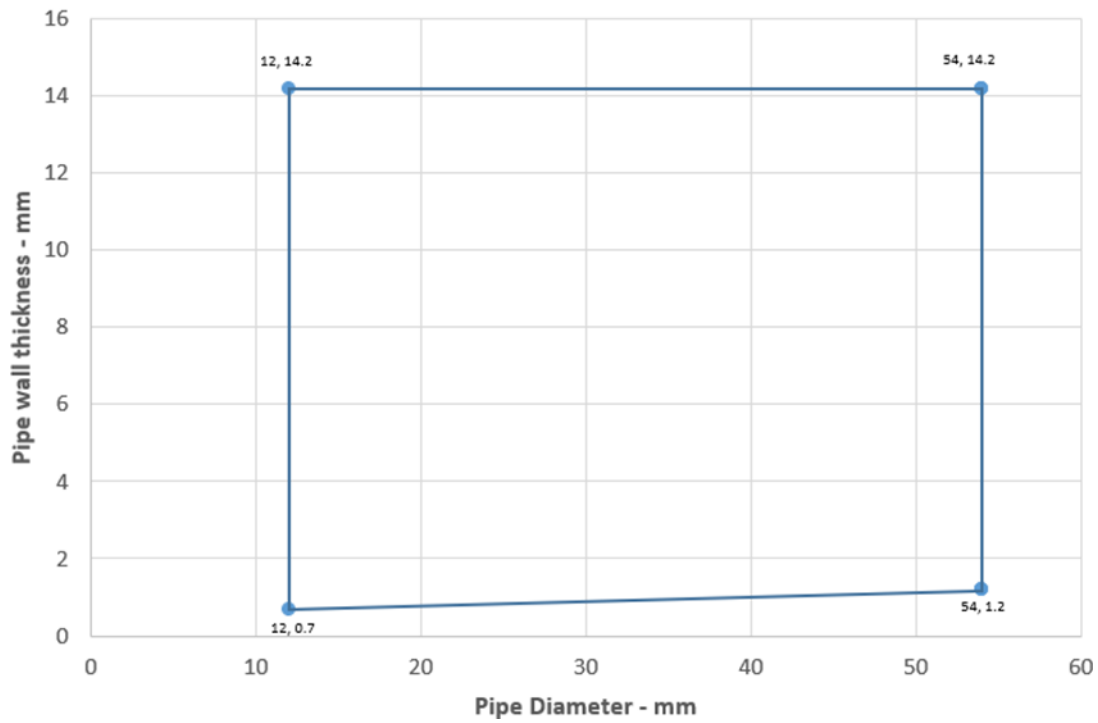

Figure 19 Intermediate pipe wall thicknesses for copper or steel pipe diameters

Alupex Pipes 16-75 / 9-50 mm Elastomeric Insulation - C/C

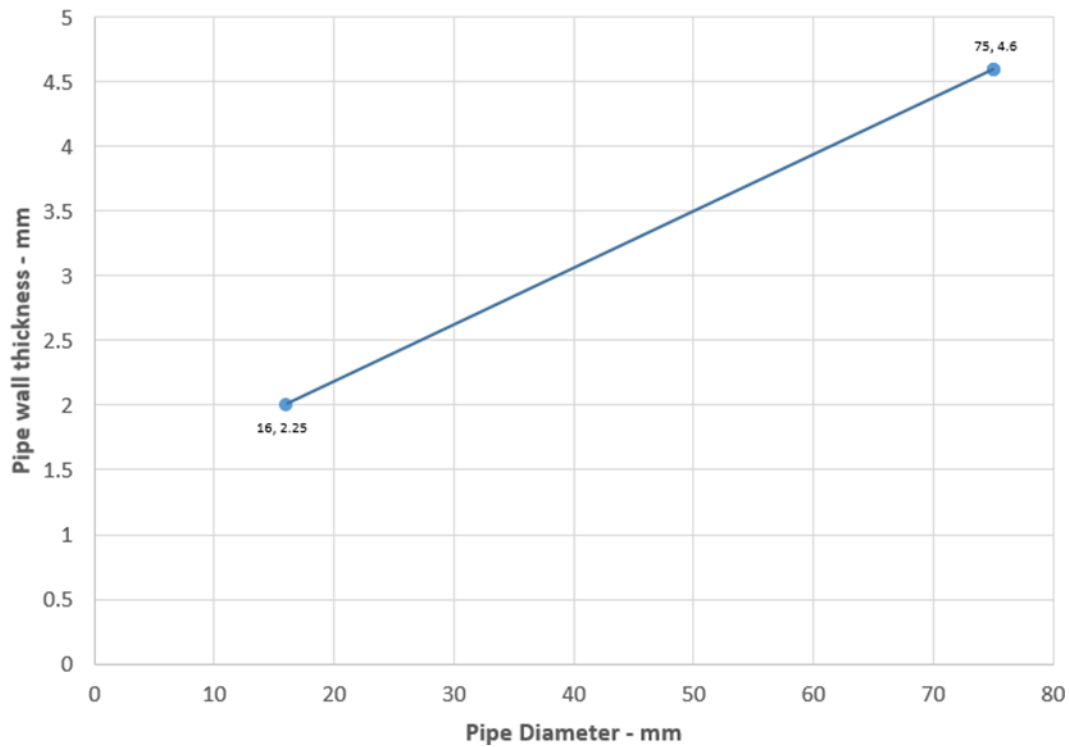

Figure 20 Intermediate pipe wall thicknesses for Alupex pipe diameters

Table 26 PE and PP pipes protected with Protecta FR collar on both sides

Services	Insulation	Collar	FRL
PE pipe			
Maximum diameter 50 mm, wall thickness 3.0-9.5 mm*	9-50 mm thick Elastomeric insulation minimum class D-s3, d0	Up to 110 mm collar at 50 mm height, 125-200 mm at 60 mm height, 250-315 mm at 75 mm height	-/90/90 C/C
Diameter 160 mm, wall thickness 4.9-9.5 mm			-/120/120 C/C
PP pipe			
Maximum diameter 50 mm, wall thickness 1.8-14.6 mm*	9-50 mm thick Elastomeric insulation minimum class D-s3, d0	Up to 110 mm collar at 50 mm height, 125-200 mm at 60 mm height, 250-315 mm at 75 mm height	-/90/90 C/C
Diameter 160 mm, wall thickness 4.9-14.6 mm			-/120/120 C/C
*Typical pipe diameters shown, see below graphs for intermediate sizes			

PE Pipes 50-160 with Elastomeric Insulation - C/C

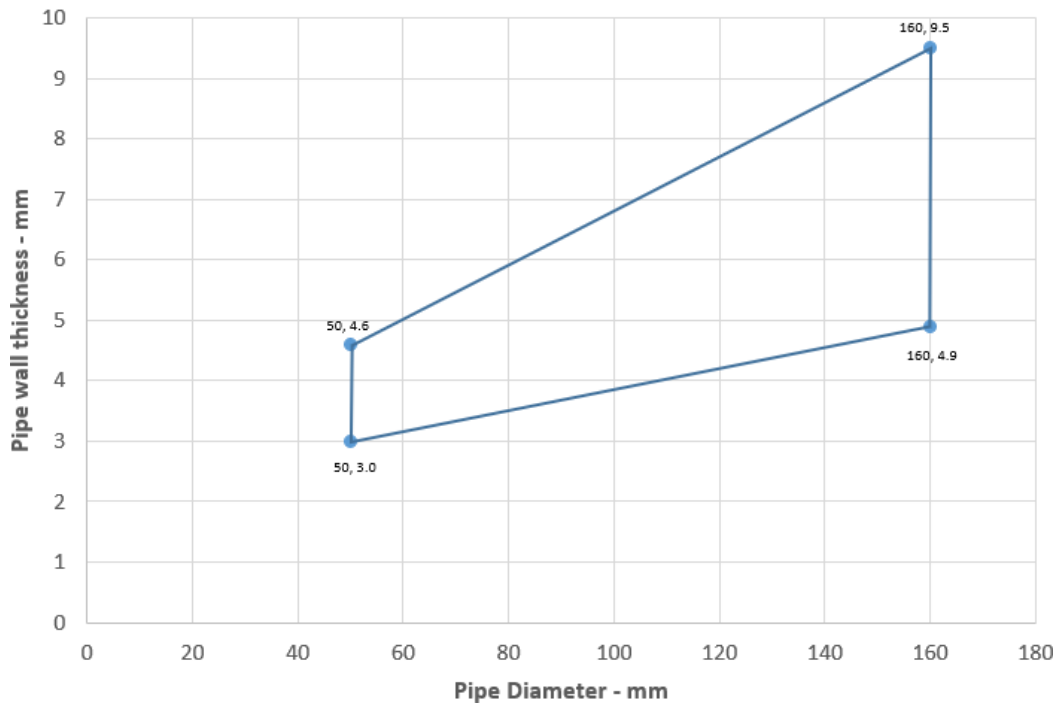

Figure 21 Intermediate pipe wall thicknesses for PE pipe diameters

PP Pipes 50-160 with Elastomeric Insulation - C/C

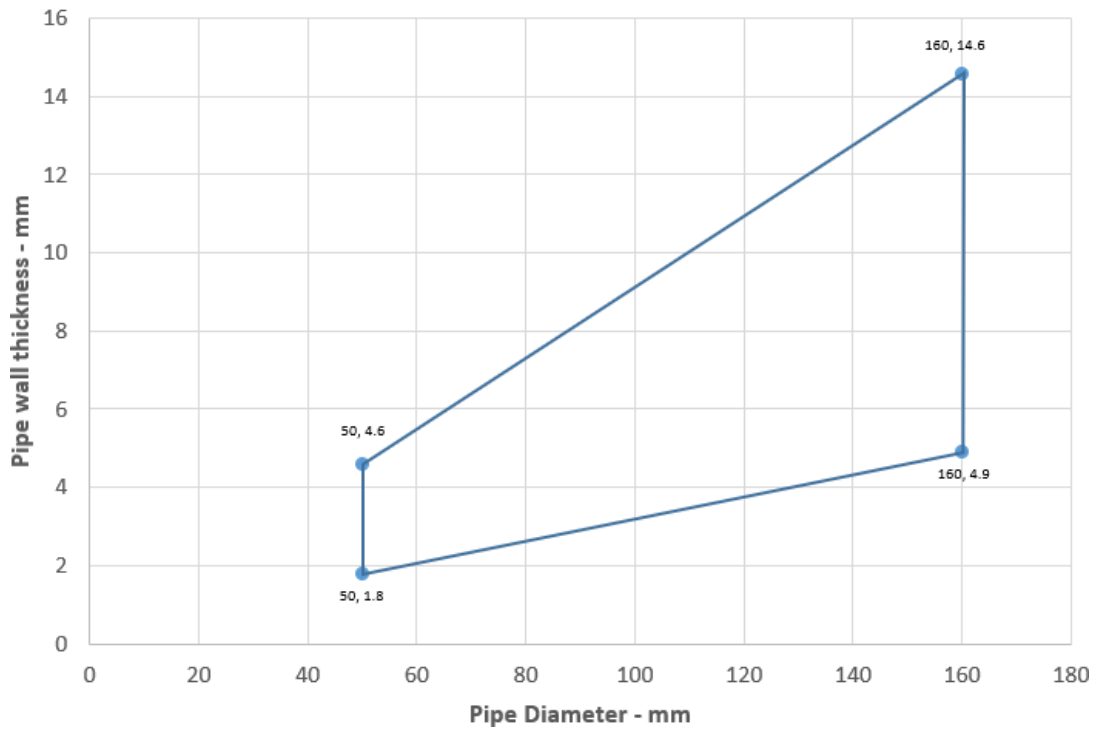

Figure 22 Intermediate pipe wall thicknesses for PP pipe diameters

6.4.4 Penetration seals, in drywalls and concrete/masonry walls

Penetration seal: Combustible pipes fitted with Protecta FR Collar, to both sides of the FR Board. Minimum separation between penetration seals and seal edges of 50 mm (Configuration 1 & 2). Maximum seal size 1200 mm wide × 600 mm high.

Construction details:

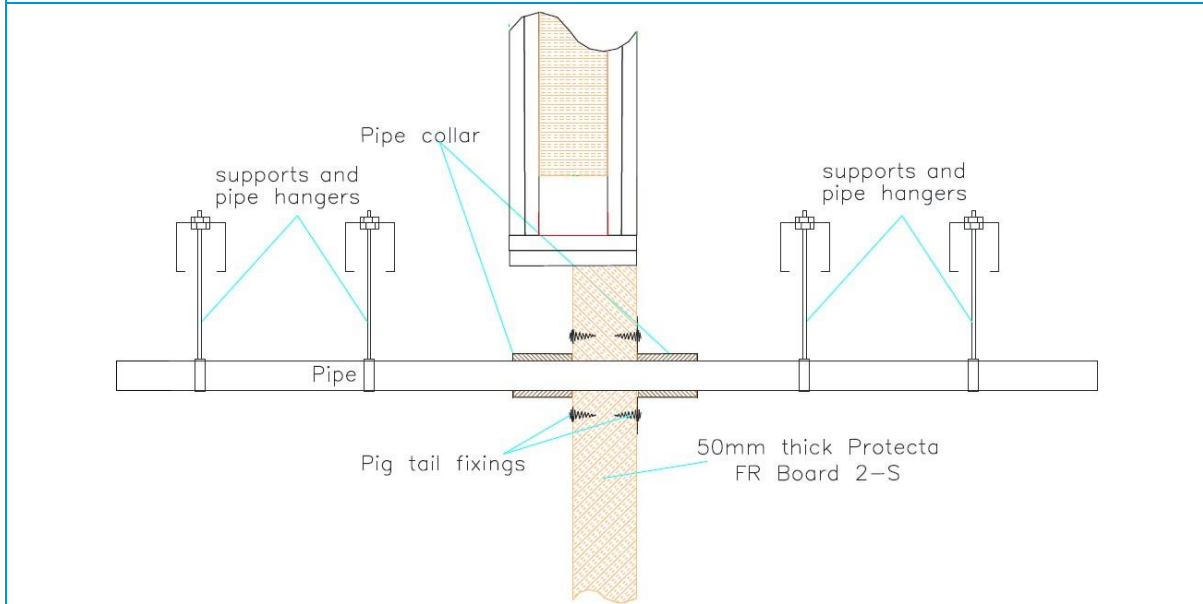

Table 27 PVC-U pipes protected with Protecta FR collar on both sides penetrating Protecta FR board

Services	Collar inlay	FRL
PVC-U pipe		
32-50 mm diameter / 1.9-3.7 mm wall thickness	50 × 3.0 mm	-/120/60 U/C
55 mm, / 1.9-4.0 mm wall thickness	50 × 3.2 mm	-/90/60 U/C
63 mm, / 2.0-4.4 mm wall thickness	50 × 3.6 mm	
75 mm, / 2.2-4.9 mm wall thickness	50 × 4.2 mm	
82 mm, / 2.3-5.3 mm wall thickness	50 × 4.6 mm	
90 mm, / 2.4-5.7 mm wall thickness	50 × 5.0 mm	
110 mm diameter / 2.7-6.6 mm wall thickness	50 × 6.0 mm	

PVC pipes 50-110 / 50 mm Collar - U/C

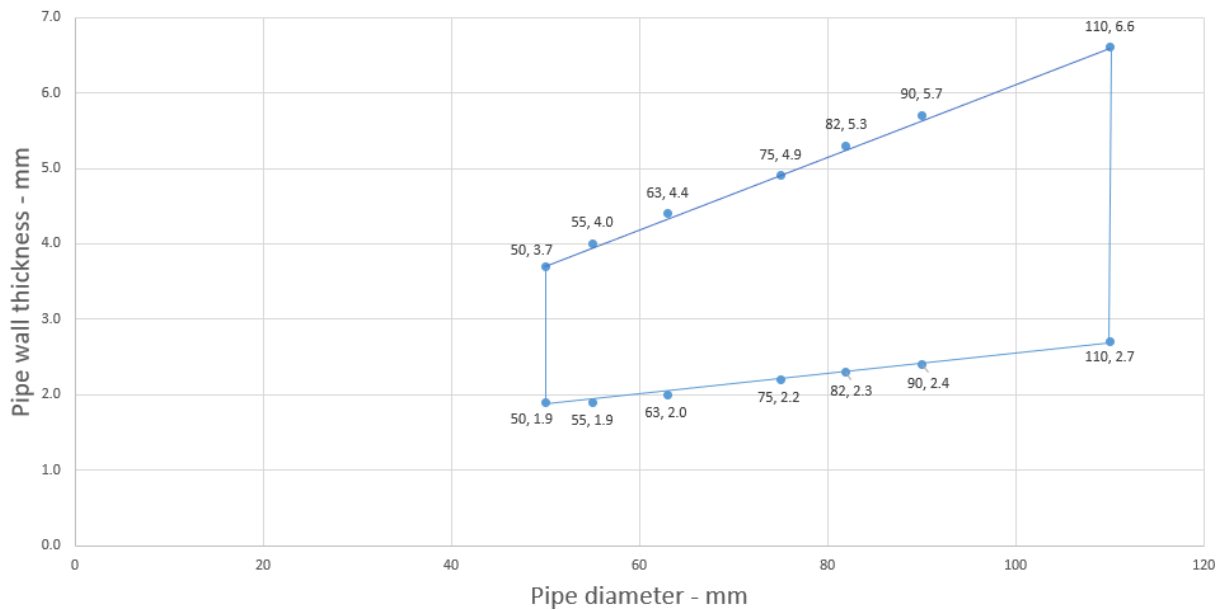

Figure 23 Intermediate pipe wall thicknesses for PVC pipe diameters

Table 28 PE pipes protected with Protecta FR collar on both sides penetrating Protecta FR board

Services	Collar inlay	FRL
PE pipe		
32-50 mm diameter / 3.0-4.6 mm wall thickness	50 × 3.0 mm	-/120/60 U/C
55 mm, / 3.0-5.2 mm wall thickness	50 × 3.2 mm	
63 mm, / 3.0-5.9 mm wall thickness	50 × 3.6 mm	
75 mm, / 3.1-6.9 mm wall thickness	50 × 4.2 mm	
82 mm, / 3.1-7.6 mm wall thickness	50 × 4.6 mm	
90 mm, / 3.2-8.3 mm wall thickness	50 × 5.0 mm	
110 mm, / 3.4-10.0 mm wall thickness	50 × 6.0 mm	

PE pipes 50-110 / 50 mm Collar - C/C

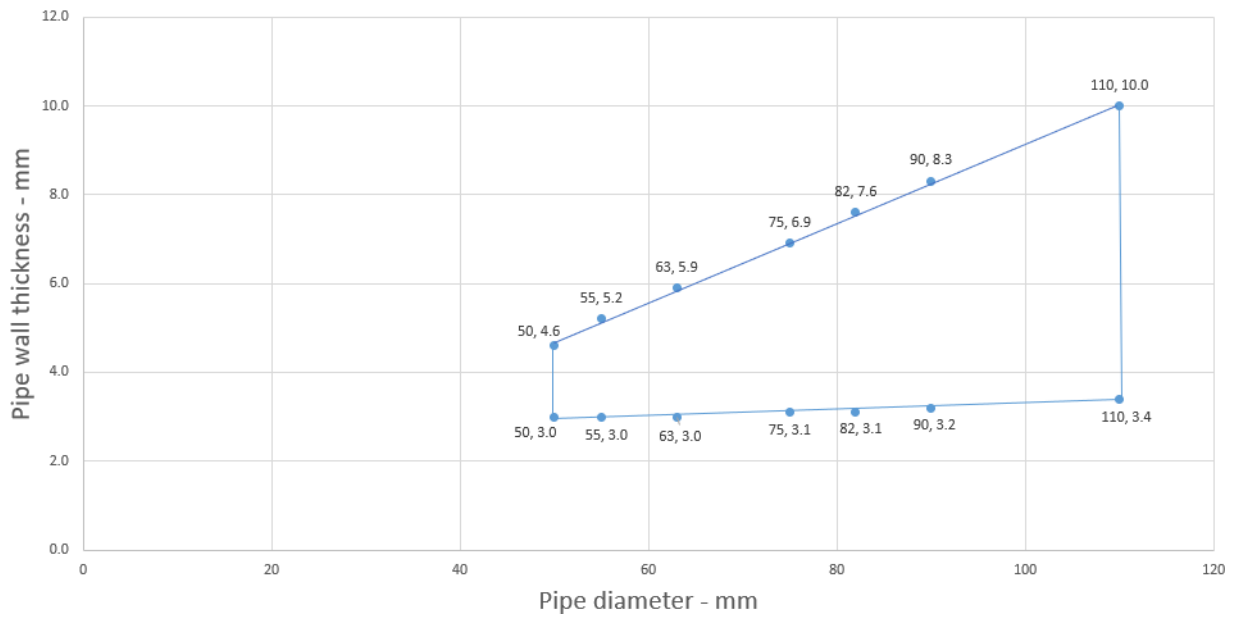

Figure 24 Intermediate pipe wall thicknesses for PE pipe diameters

6.5 Flexible or rigid wall constructions with wall thickness of minimum 120 mm

6.5.1 Flexible or rigid wall constructions with wall thickness of minimum 120 mm

Penetration seal: Combustible pipes fitted with Protecta FR Collar, to both sides of the wall.

Construction details:

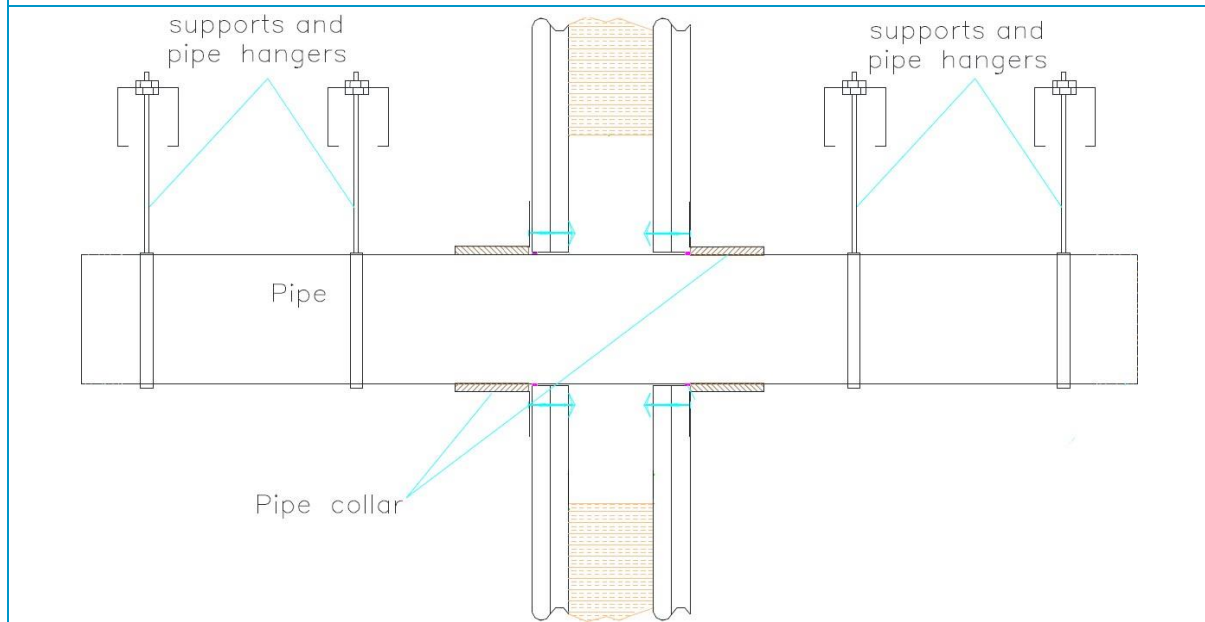

Table 29 PVC-U pipes (diameter 32-110 mm) protected with Protecta FR collar on both sides of the wall

Services	Collar inlay	FRL
PVC-U pipe		
Diameter 32-50 mm, wall thickness 2.4-3.7 mm*	50 × 3.0 mm	-/120/120 C/C
Diameter 55 mm, wall thickness 2.4-3.9 mm*	50 × 3.2 mm	
Diameter 63 mm, wall thickness 2.5-4.3 mm*	50 × 3.6 mm	
Diameter 75 mm, wall thickness 2.5-4.9 mm*	50 × 4.2 mm	
Diameter 82 mm, wall thickness 2.6-5.2 mm*	50 × 4.6 mm	
Diameter 90 mm, wall thickness 2.6-5.6 mm*	50 × 5.0 mm	
Diameter 110 mm, wall thickness 2.7-6.6 mm*	50 × 6.0 mm	
* Typical pipe diameters shown, see below graph for intermediate sizes		

PVC Pipes 50-110 / 50 mm Collar -C/C

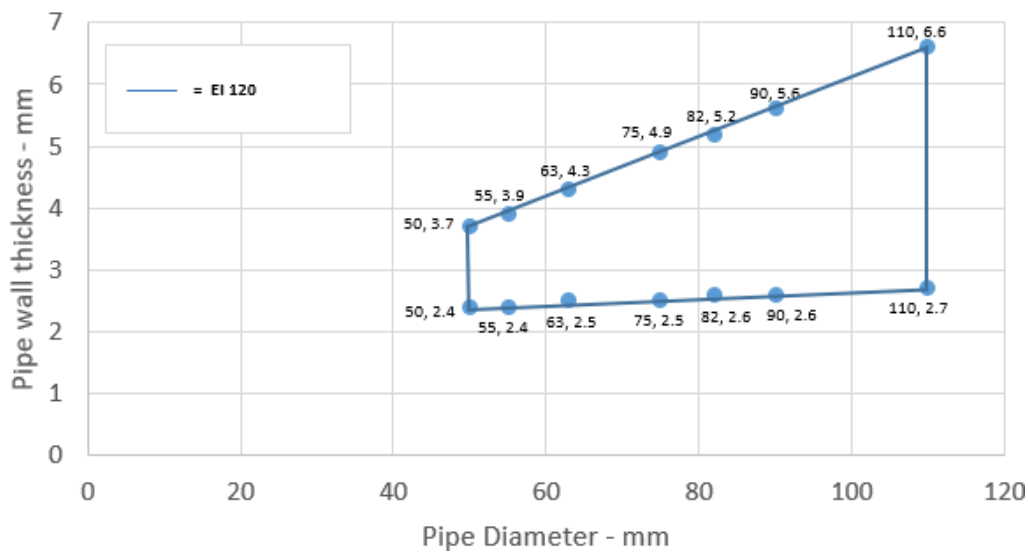

Figure 25 Intermediate pipe wall thicknesses for PVC pipe diameters

Table 30 PVC-U pipes (diameter 110-160 mm) protected with Protecta FR collar on both sides of the wall

Services	Collar inlay	FRL
PVC-U pipe		
Diameter 110 mm, wall thickness 2.7-6.6 mm*	50 × 6.0 mm	-/120/120 C/C
Diameter 125 mm, wall thickness 3.1-7.5 mm*	60 × 8.8 mm	
Diameter 140 mm, wall thickness 3.5-8.4 mm*	60 × 11.5 mm	
Diameter 160 mm, wall thickness 4.0-9.5 mm*	60 × 15.0 mm	
* Typical pipe diameters shown, see below graph for intermediate sizes		

PVC Pipes 125-160 / 60 mm Collar - C/C

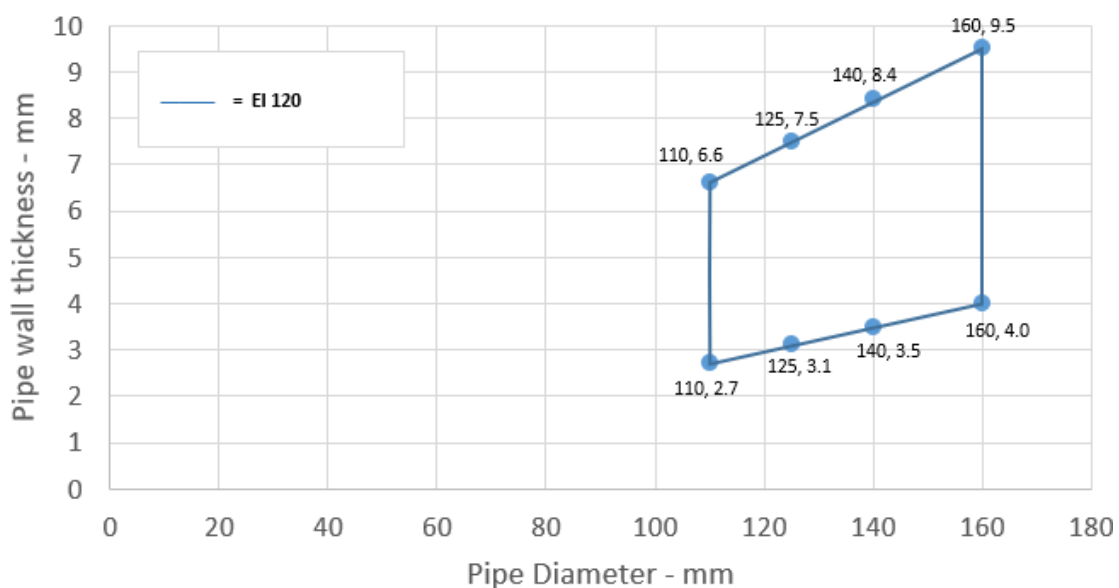

Figure 26 Intermediate pipe wall thicknesses for PVC pipe diameters

Table 31 PE pipes (diameter 32-110 mm) protected with Protecta FR collar on both sides of the wall

Services	Collar inlay	FRL
PE pipe		
Diameter 32-50 mm, wall thickness 3.0-4.6 mm*	50 × 3.0 mm	-/120/120 C/C
Diameter 55 mm, wall thickness 3.1-5.0 mm*	50 × 3.2 mm	
Diameter 63 mm, wall thickness 3.1-5.7 mm*	50 × 3.6 mm	
Diameter 75 mm, wall thickness 3.2-6.8 mm*	50 × 4.2 mm	
Diameter 82 mm, wall thickness 3.2-7.5 mm*	50 × 4.6 mm	
Diameter 90 mm, wall thickness 3.3-8.2 mm*	50 × 5.0 mm	
Diameter 110 mm, wall thickness 3.4-10.0 mm*	50 × 6.0 mm	
Diameter 110 mm, wall thickness 3.4 mm*	50 × 6.0 mm	-/120/120 C/C

* Typical pipe diameters shown, see below graph for intermediate sizes

PE Pipes 50-110 / 50 mm Collar - C/C

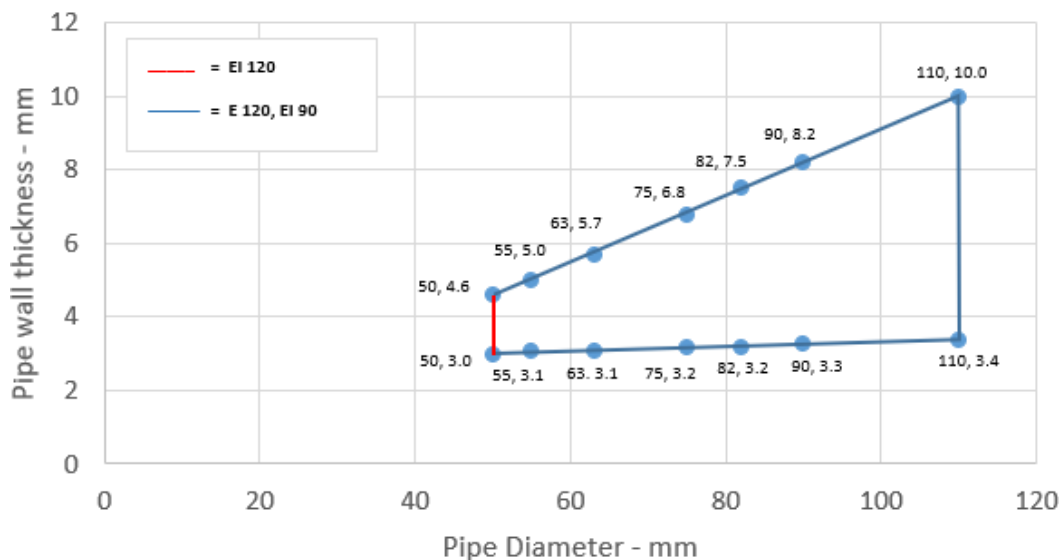

Figure 27 Intermediate pipe wall thicknesses for PE pipe diameters

Table 32 PE pipes (diameter 110-160 mm) protected with Protecta FR collar on both sides of the wall

Services	Collar inlay	FRL
PE pipe		
Diameter 110 mm, wall thickness 3.4-10.0 mm*	50 × 6.0 mm	-/120/90 C/C
Diameter 125 mm, wall thickness 3.9-9.8 mm*	60 × 8.8 mm	
Diameter 140 mm, wall thickness 4.4-9.7 mm*	60 × 11.5 mm	-/120/120 C/C
Diameter 160 mm, wall thickness 4.9-9.5 mm*	60 × 15.0 mm	

* Typical pipe diameters shown, see below graph for intermediate sizes

PE Pipes 125-160 / 60 mm Collar - C/C

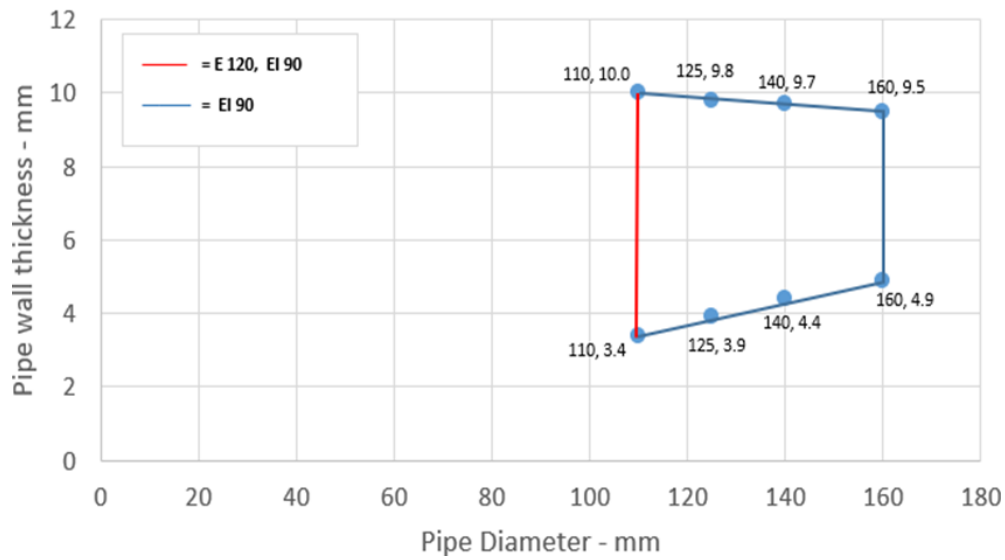

Figure 28 Intermediate pipe wall thicknesses for PE pipe diameters

Table 33 PE pipes (diameter 110-160 mm) protected with Protecta FR collar on both sides of the wall

Services	Collar inlay	FRL
PE pipe		
Diameter 110 mm, wall thickness 3.4 mm*	50 × 6.0 mm	-/120/120 C/C
Diameter 125 mm, wall thickness 3.9-5.3 mm*	60 × 8.8 mm	
Diameter 140 mm, wall thickness 4.3-7.1 mm*	60 × 11.5 mm	
Diameter 160 mm, wall thickness 4.9-9.5 mm*	60 × 15.0 mm	
* Typical pipe diameters shown, see below graph for intermediate sizes		

PE Pipes 110-200 / 60 mm Collar

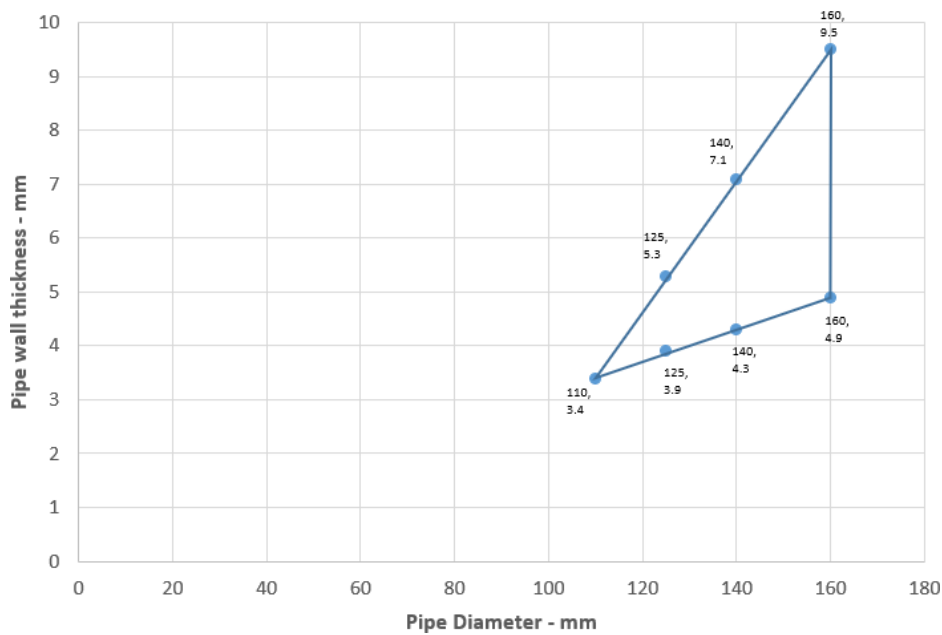

Figure 29 Intermediate pipe wall thicknesses for PE pipe diameters

Table 34 PP pipes (diameter 32-110 mm) protected with Protecta FR collar on both sides of the wall

Services	Collar inlay	FRL
PP pipe		
Diameter 32-50 mm, wall thickness 2.9-4.6 mm	50 × 3.0 mm	-/120/90 C/C
Diameter 55 mm, wall thickness 2.9-5.0 mm*	50 × 3.2 mm	
Diameter 63 mm, wall thickness 2.9-5.7 mm*	50 × 3.6 mm	
Diameter 75 mm, wall thickness 2.8-6.8 mm*	50 × 4.2 mm	
Diameter 82 mm, wall thickness 2.8-7.5 mm*	50 × 4.6 mm	
Diameter 90 mm, wall thickness 2.8-8.2 mm*	50 × 5.0 mm	
Diameter 110 mm, wall thickness 2.7-10 mm*	50 × 6.0 mm	
* Typical pipe diameters shown, see below graph for intermediate sizes		

PP Pipes 50-110 / 50 mm Collar - C/C

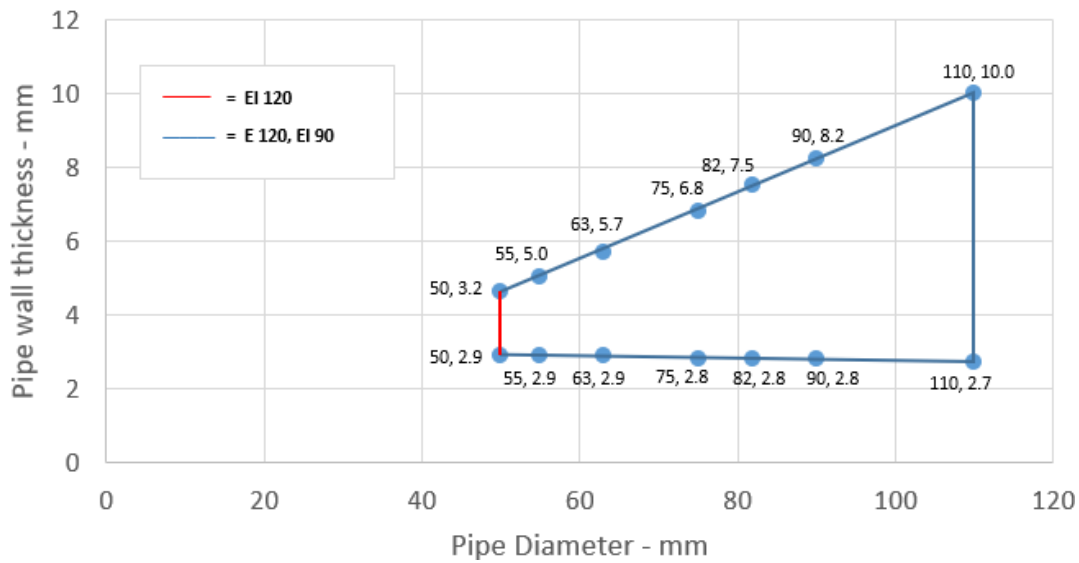

Figure 30 Intermediate pipe wall thicknesses for PP pipe diameters

Table 35 PP pipes (diameter 110-160 mm) protected with Protecta FR collar on both sides of the wall

Services	Collar inlay	FRL
PP pipe		
Diameter 110 mm, wall thickness 2.7-10 mm*	50 × 6.0 mm	-/120/90 C/C
Diameter 125 mm, wall thickness 3.3-11.3 mm*	60 × 8.8 mm	
Diameter 140 mm, wall thickness 4.0-12.8 mm*	60 × 11.5 mm	
Diameter 160 mm, wall thickness 4.9-14.6 mm*	60 × 15.0 mm	-/120/120 C/C

* Typical pipe diameters shown, see below graph for intermediate sizes

PP Pipes 125-160 / 60 mm collar - C/C

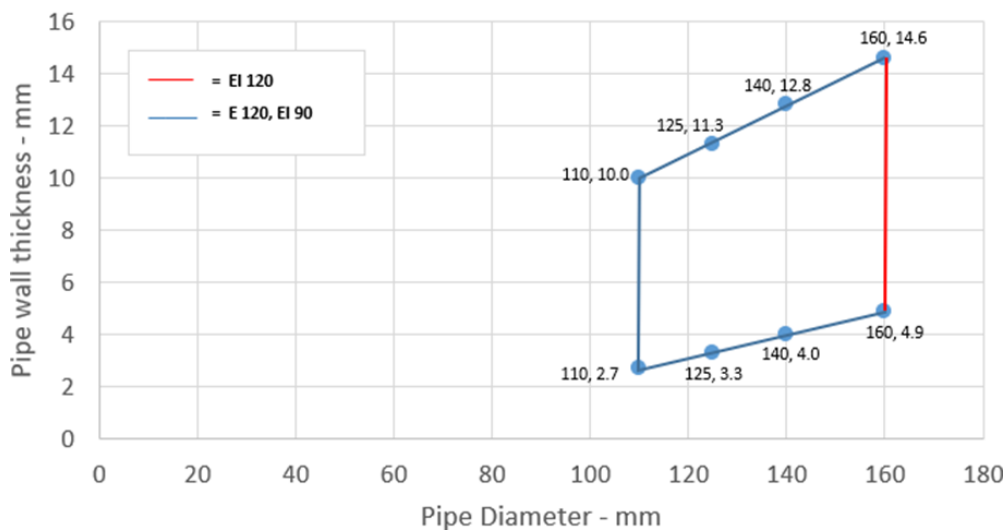

Figure 31 Intermediate pipe wall thicknesses for PP pipe diameters

6.5.2 Oversize penetration seals, in drywalls and concrete/masonry walls or floors

Penetration seal example: Combustible pipes fitted with Protecta FR Collar, to both sides of the wall.

Construction details:

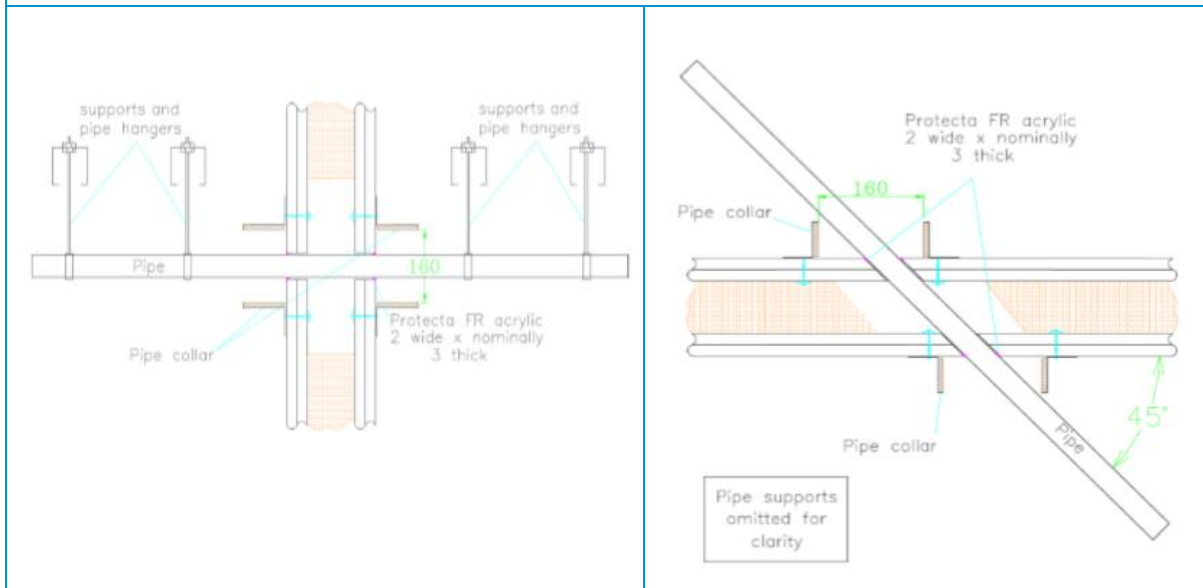

Table 36 PVC-U pipe installed at an angle (45°)

Services	Collar inlay	FRL
PVC-U pipe		
Diameter 50 mm, wall thickness 2.4 mm*	60 × 15.0 mm	-/90/90 C/C
<p>*Pipe fitted at 45° to the face of the partition in a horizontal plane</p> <p>Note: Oversize collars can be used as a method of fire protection in both walls and floors for any type of services as assessed in section 6 including both pipes and cables where the requirement for oversize collars arise due to angling of services or oversized apertures. However, when used with over-sized collars, the fire resistance performance of any 180 minutes or 240 minutes systems must be reduced to maximum 120 minutes in integrity and insulation.</p>		

6.6 Rigid walls constructions with wall thickness of minimum 150 mm

6.6.1 Penetration seals, in concrete/masonry walls

Penetration seal: Combustible pipes fitted with Protecta FR Collar, to both sides of the wall.

Construction details:

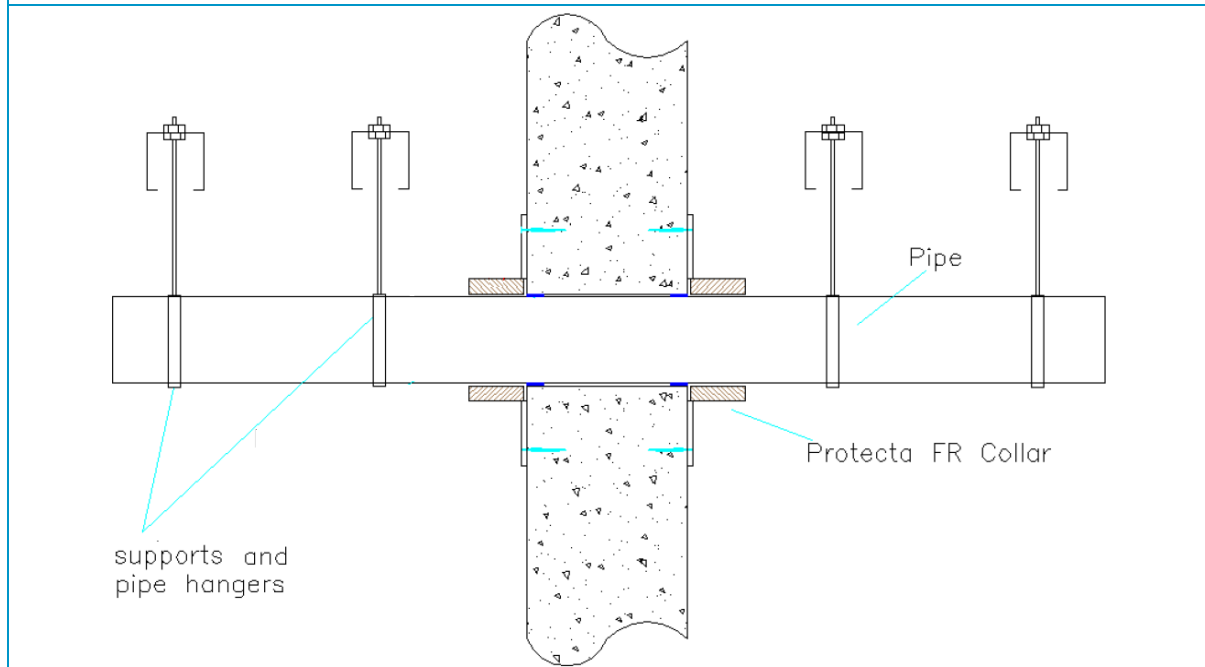

Table 37 PVC-U pipes (diameters 32 – 110 mm) protected with Protecta FR Collar installed at both sides of a rigid wall

Services	Collar inlay	FRL
PVC-U pipe		
Diameter 32 mm, wall thickness 2.0-3.7 mm*	50 × 3.0 mm	-/240/180 U/U, C/U, U/C, C/C
Diameter 40 mm, wall thickness 2.0-3.7 mm*		
Diameter 50 mm, wall thickness 2.0-3.7 mm*		
Diameter 55 mm, wall thickness 2.1-3.9 mm*	50 × 3.2 mm	-/180/180 U/U, C/U, U/C, C/C
Diameter 63 mm, wall thickness 2.2-4.3 mm*	50 × 3.6 mm	
Diameter 75 mm, wall thickness 2.3-4.9 mm*	50 × 4.2 mm	
Diameter 82 mm, wall thickness 2.4-5.2 mm*	50 × 4.6 mm	
Diameter 90 mm, wall thickness 2.5-5.6 mm*	50 × 5.0 mm	
Diameter 110 mm, wall thickness 2.7-6.6 mm*	50 × 6.0 mm	
* Typical pipe diameters shown, see below graph for intermediate sizes		

PVC Pipes 32-110 / 50 mm Collar - U/U

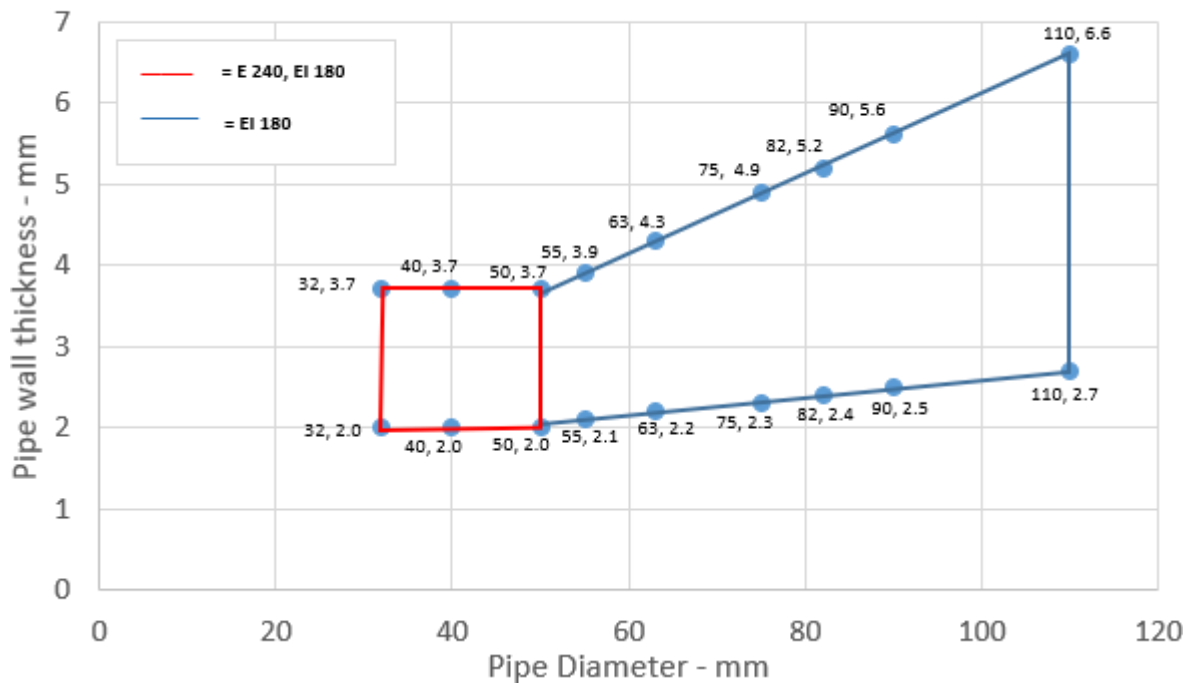

Figure 32 Intermediate pipe wall thicknesses for PVC pipe diameters

Table 38 PVC-U pipes (diameters 110 – 315 mm) protected with Protecta FR Collar installed at both sides of a rigid wall

Services	Collar inlay	FRL
PVC-U pipe		
Diameter 110 mm, wall thickness 2.7-6.6 mm*	50 × 6.0 mm	-/180/180 U/U, C/U, U/C, C/C
Diameter 125 mm, wall thickness 3.1-7.5 mm*	60 × 8.8 mm	-/240/240 U/U, C/U, U/C, C/C
Diameter 140 mm, wall thickness 3.5-8.4 mm*	60 × 11.5 mm	
Diameter 160 mm, wall thickness 4.0-9.5 mm*	60 × 15.0 mm	-/240/120 U/C, C/C
Diameter 315 mm, wall thickness 9.2 mm	75 × 18 mm	-/120/120 C/C
* Typical pipe diameters shown, see below graph for intermediate sizes		

PVC Pipes 125-160 / 60 mm Collar - U/U

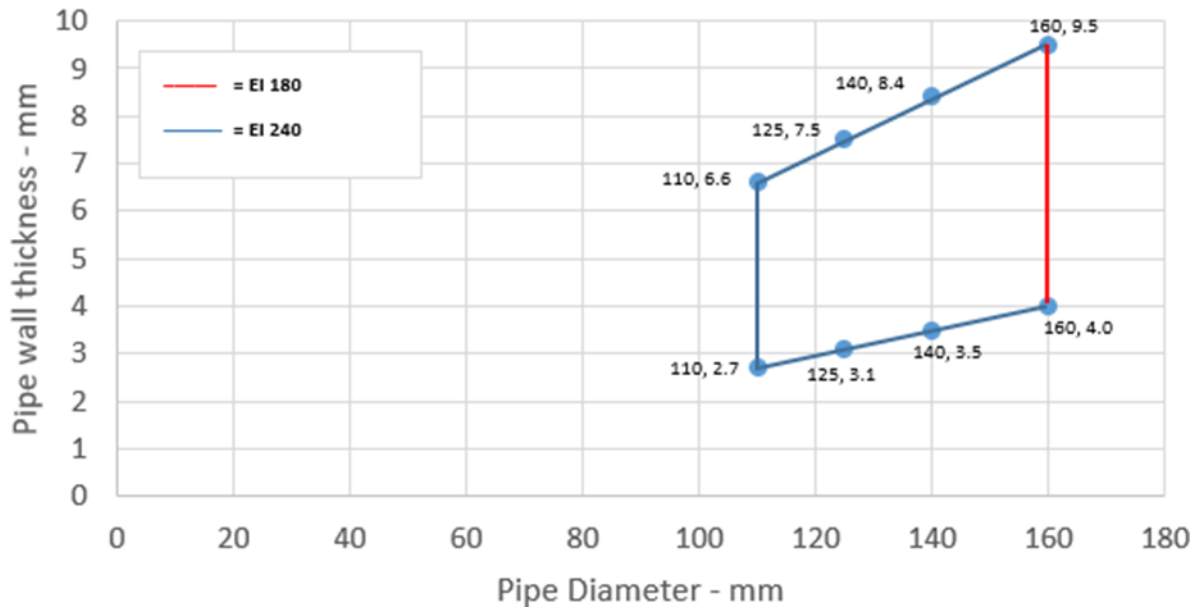

Figure 33 Intermediate pipe wall thicknesses for PVC pipe diameters

Table 39 PE pipes (diameters 32 – 110 mm) protected with Protecta FR Collar installed at both sides of a rigid wall

Services	Collar inlay	FRL
PE pipe		
Diameter 32 mm, wall thickness 3.0-4.6 mm*	50 × 3.0 mm	-/240/240 U/U, C/U, U/C, C/C
Diameter 40 mm, wall thickness 3.0-4.6 mm*		
Diameter 50 mm, wall thickness 3.0-4.6 mm*		
Diameter 55 mm, wall thickness 3.1-4.5 mm*	50 × 3.2 mm	-/240/180 U/U, C/U, U/C, C/C
Diameter 63 mm, wall thickness 3.1-4.3 mm*	50 × 3.6 mm	
Diameter 75 mm, wall thickness 3.2-4.1 mm*	50 × 4.2 mm	
Diameter 82 mm, wall thickness 3.3-3.9 mm*	50 × 4.6 mm	
Diameter 90 mm, wall thickness 3.3-3.8 mm*	50 × 5.0 mm	
Diameter 110 mm, wall thickness 3.4 mm*	50 × 6.0 mm	
* Typical pipe diameters shown, see below graph for intermediate sizes		

PE Pipes 32-110 / 50 mm Collar-U/U

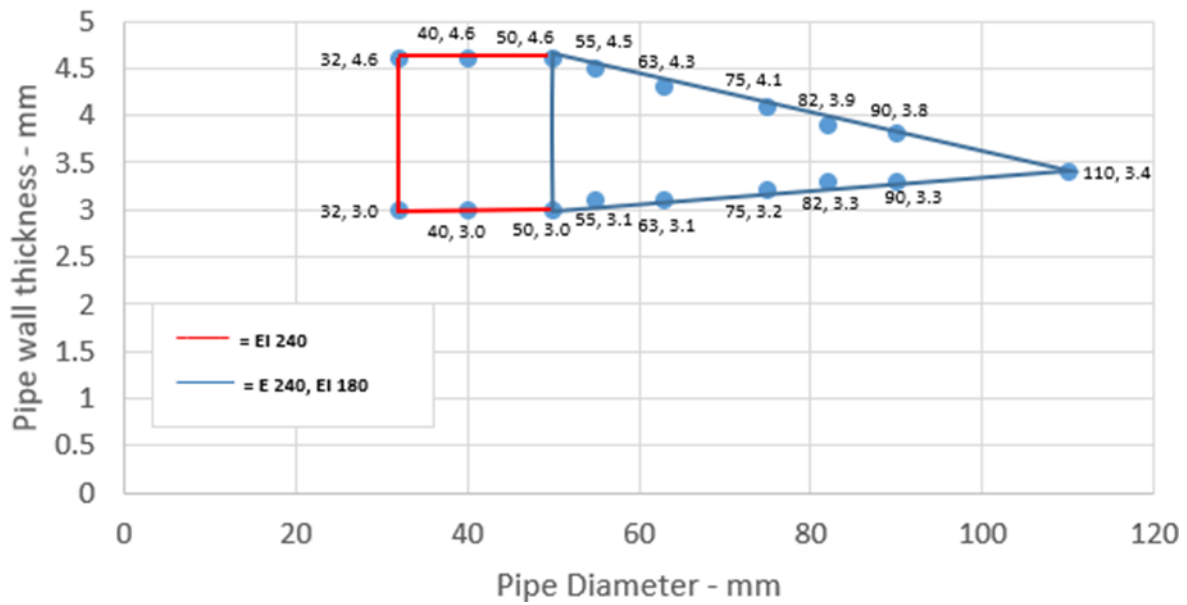

Figure 34 Intermediate pipe wall thicknesses for PE pipe diameters

Table 40 PE pipes (diameters 110 – 250 mm) protected with Protecta FR Collar installed at both sides of a rigid wall

Services	Collar inlay	FRL
PE pipe		
Diameter 110 mm, wall thickness 3.4 mm*	50 × 6.0 mm	-/240/180 U/U, C/U, U/C, C/C
Diameter 125 mm, wall thickness 3.9-5.2 mm*	60 × 9.0 mm	-/180/180 U/U, C/U, U/C, C/C
Diameter 140 mm, wall thickness 4.3-7.0 mm*	60 × 11.5 mm	
Diameter 160 mm, wall thickness 4.9-9.5 mm*	60 × 15.0 mm	
Diameter 200 mm, wall thickness 18.2 mm	75 × 10.8 mm	-/60/60 C/C
Diameter 250 mm, wall thickness 22.7 mm	75 × 12.6 mm	-/120/90 C/C
* Typical pipe diameters shown, see below graph for intermediate sizes		

PE Pipes 125-160 / 60 mm Pipes - U/U

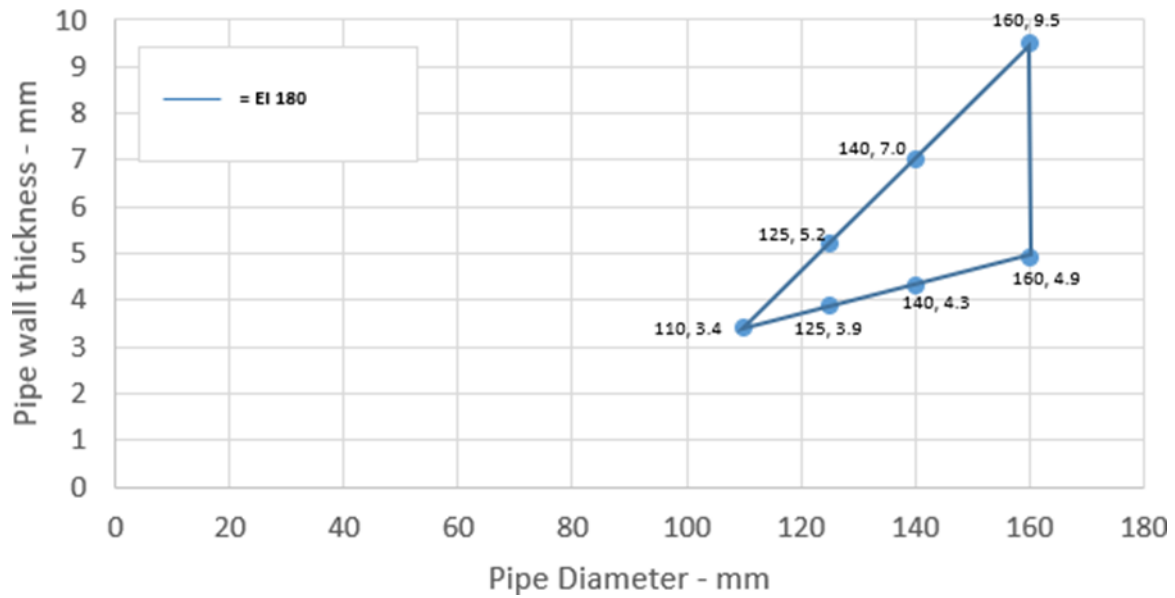

Figure 35 Intermediate pipe wall thicknesses for PE pipe diameters

Table 41 PE pipes (diameters 50 – 160 mm) protected with Protecta FR Collar installed at both sides of a rigid wall

Services	Collar inlay	FRL
PE pipe		
Diameter 50 mm, wall thickness 3.0-4.6 mm*	50 × 3.0 mm	-/180/180 U/U, C/U, U/C, C/C
Diameter 55 mm, wall thickness 3.1-4.8 mm*	50 × 3.2 mm	-/180/120 U/C, C/C
Diameter 63 mm, wall thickness 3.1-5.0 mm*	50 × 3.6 mm	
Diameter 75 mm, wall thickness 3.2-5.4 mm*	50 × 4.2 mm	
Diameter 82 mm, wall thickness 3.2-5.7 mm*	50 × 4.6 mm	
Diameter 90 mm, wall thickness 3.3-5.9 mm*	50 × 5.0 mm	
Diameter 110 mm, wall thickness 3.4-6.6 mm*	50 × 6.0 mm	
Diameter 125 mm, wall thickness 3.8-7.5 mm*	60 × 9.0 mm	
Diameter 140 mm, wall thickness 4.3-8.3 mm*	60 × 11.5 mm	-/180/180 U/U, C/U, U/C, C/C
Diameter 160 mm, wall thickness 4.9-9.5 mm*	60 × 15.0 mm	
* Typical pipe diameters shown, see below graph for intermediate sizes		

PE Pipes 50-110 / 50 mm Collar

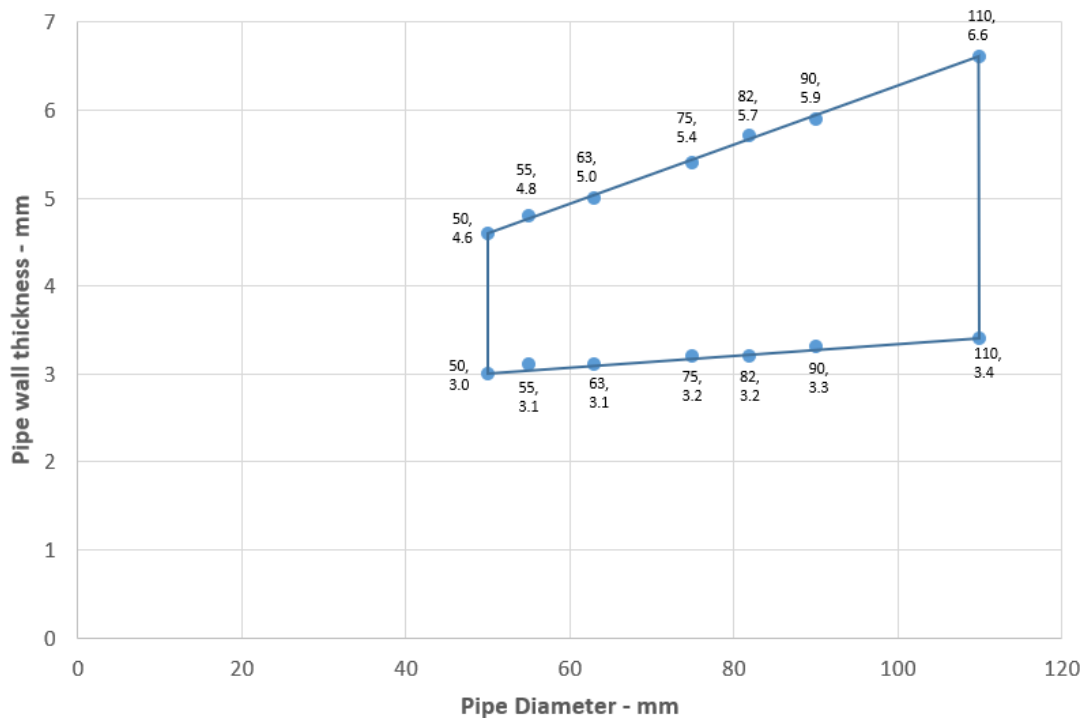

Figure 36 Intermediate pipe wall thicknesses for PE pipe diameters

PE Pipes 125-160 / 60 mm Collar

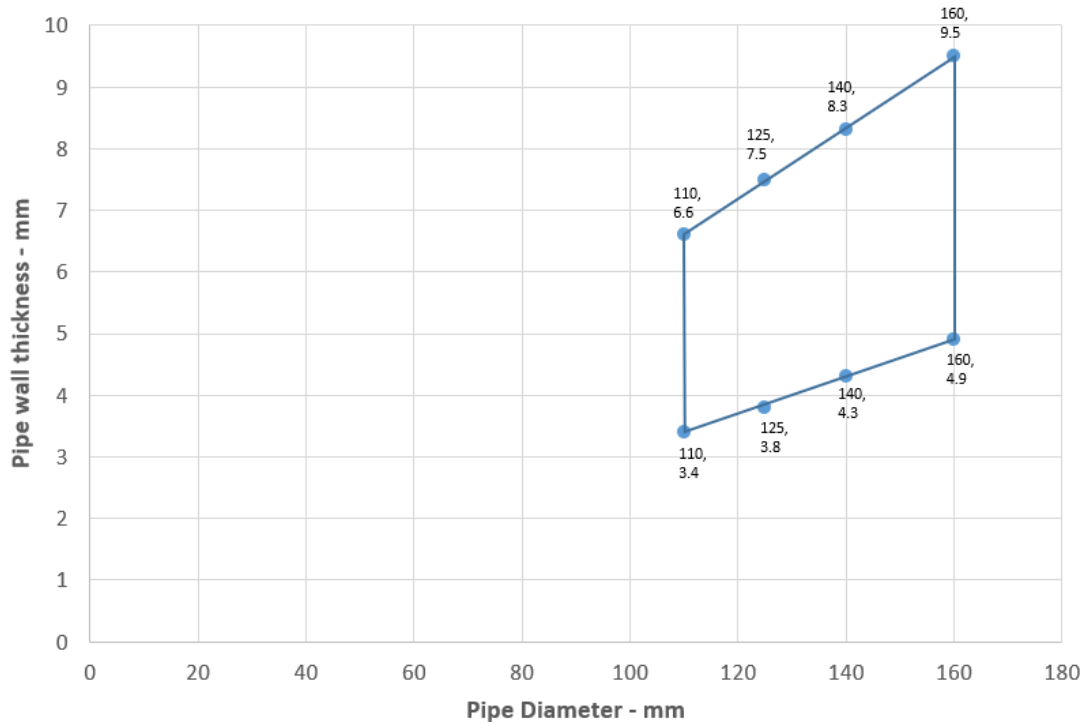

Figure 37 Intermediate pipe wall thicknesses for PE pipe diameters

Table 42 PP pipes (diameters 32 – 110 mm) protected with Protecta FR Collar installed at both sides of a rigid wall

Services	Collar inlay	FRL
PP pipe		
Diameter 32 mm, wall thickness 1.6-5.5 mm*	30 × 3.0 mm	-/240/240 U/C, C/C
Diameter 40 mm, wall thickness 1.6-5.5 mm*		
Diameter 50 mm, wall thickness 1.6-5.5 mm*		
Diameter 55 mm, wall thickness 1.7-5.9 mm*		
Diameter 63 mm, wall thickness 1.8-6.5 mm*	50 × 3.2 mm	
Diameter 75 mm, wall thickness 2.1-7.3 mm*	50 × 3.6 mm	
Diameter 82 mm, wall thickness 2.2-7.9 mm*	50 × 4.2 mm	
Diameter 90 mm, wall thickness 2.3-8.5 mm*	50 × 4.6 mm	
Diameter 110 mm, wall thickness 2.7-10.0 mm*	50 × 5.0 mm	
* Typical pipe diameters shown, see below graph for intermediate sizes		

PP Pipes 32-110 / 50 mm Collar - U/C

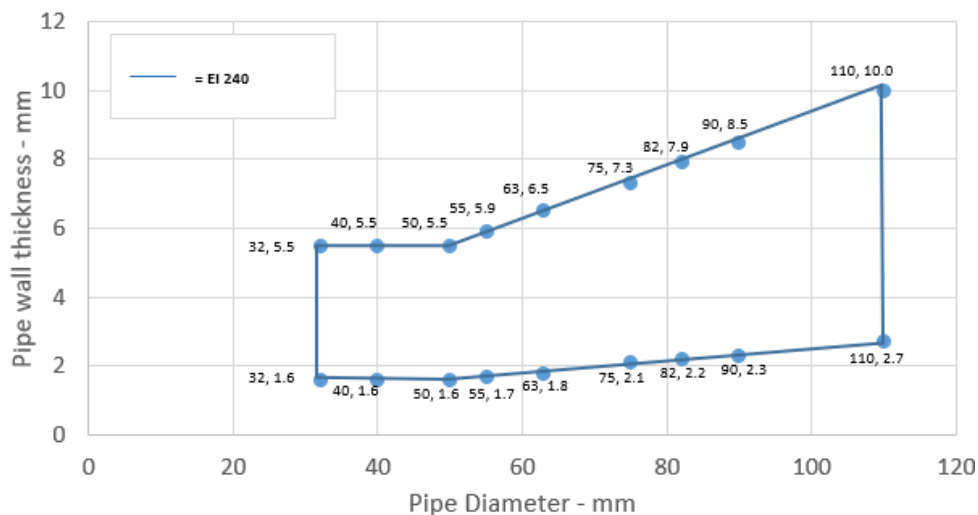

Figure 38 Intermediate pipe wall thicknesses for PP pipe diameters

Table 43 PP pipes (diameters 110 – 160 mm) protected with Protecta FR Collar installed at both sides of a rigid wall

Services	Collar inlay	FRL
PP pipe		
Diameter 110 mm, wall thickness 2.7-10.0 mm*	50 × 6.0 mm	-/240/240 U/C, C/C
Diameter 125 mm, wall thickness 3.3-11.4 mm*	60 × 9.0 mm	
Diameter 140 mm, wall thickness 4.0-12.8 mm*	60 × 11.5 mm	
Diameter 160 mm, wall thickness 4.9-14.6 mm*	60 × 15.0 mm	
* Typical pipe diameters shown, see below graph for intermediate sizes		

PP Pipes 125-160 / 60 mm Collar - U/C

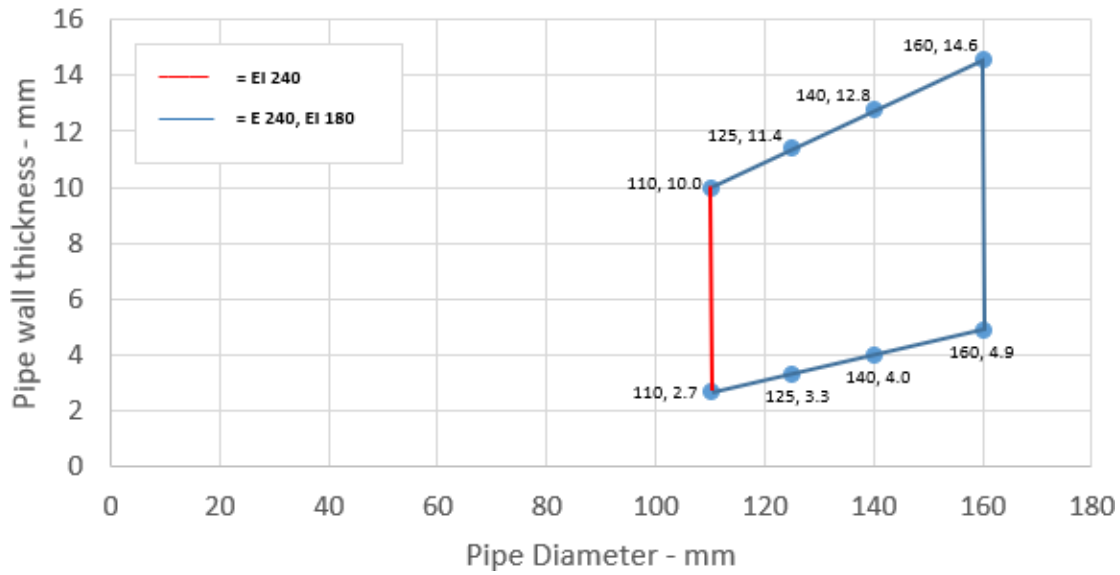

Figure 39 Intermediate pipe wall thicknesses for PP pipe diameters

Table 44 PP pipes (diameters 32 – 50 mm) protected with Protecta FR Collar installed at both sides of a rigid wall

Services	Collar inlay	FRL
PP pipe		
Diameter 32 mm, wall thickness 1.6-5.5 mm*	30 × 3.0 mm	-/240/240 U/U, C/U, U/C, C/C
Diameter 40 mm, wall thickness 1.6-5.5 mm*		
Diameter 50 mm, wall thickness 1.6-5.5 mm*		
* Typical pipe diameters shown, see below graph for intermediate sizes		

PP Pipes 32-50 / 30 mm Collar - U/U

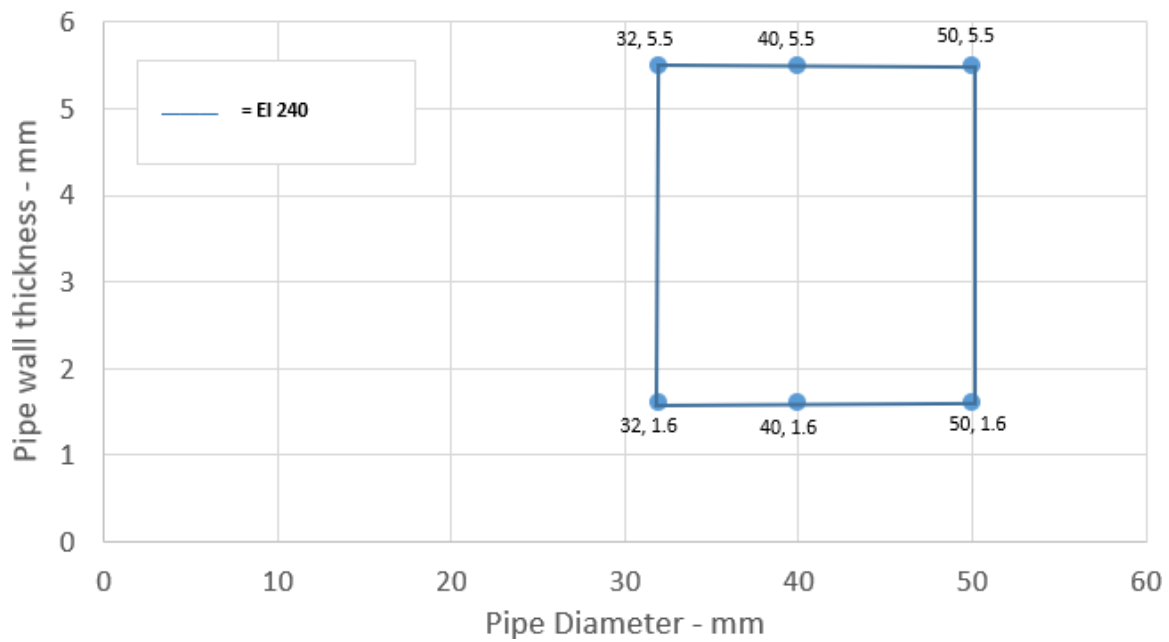

Figure 40 Intermediate pipe wall thicknesses for PP pipe diameters

Table 45 PP pipes (diameters 50 – 110 mm) protected with Protecta FR Collar installed at both sides of a rigid wall

Services	Collar inlay	FRL
PP pipe		
Diameter 50 mm, wall thickness 1.6-5.5 mm*	50 × 3.0 mm	-/240/240 U/U, C/U, U/C, C/C
Diameter 55 mm, wall thickness 1.7-5.9 mm*	50 × 3.2 mm	-/240/60 U/U, C/U
Diameter 63 mm, wall thickness 1.8-6.5 mm*	50 × 3.6 mm	
Diameter 75 mm, wall thickness 2.1-7.3 mm*	50 × 4.2 mm	
Diameter 82 mm, wall thickness 2.2-7.9 mm*	50 × 4.6 mm	
Diameter 90 mm, wall thickness 2.3-8.5 mm*	50 × 5.0 mm	
Diameter 110 mm, wall thickness 2.7-10.0 mm*	50 × 6.0 mm	
* Typical pipe diameters shown, see below graph for intermediate sizes		

PP Pipes 55-110 / 50 mm Collar - U/U

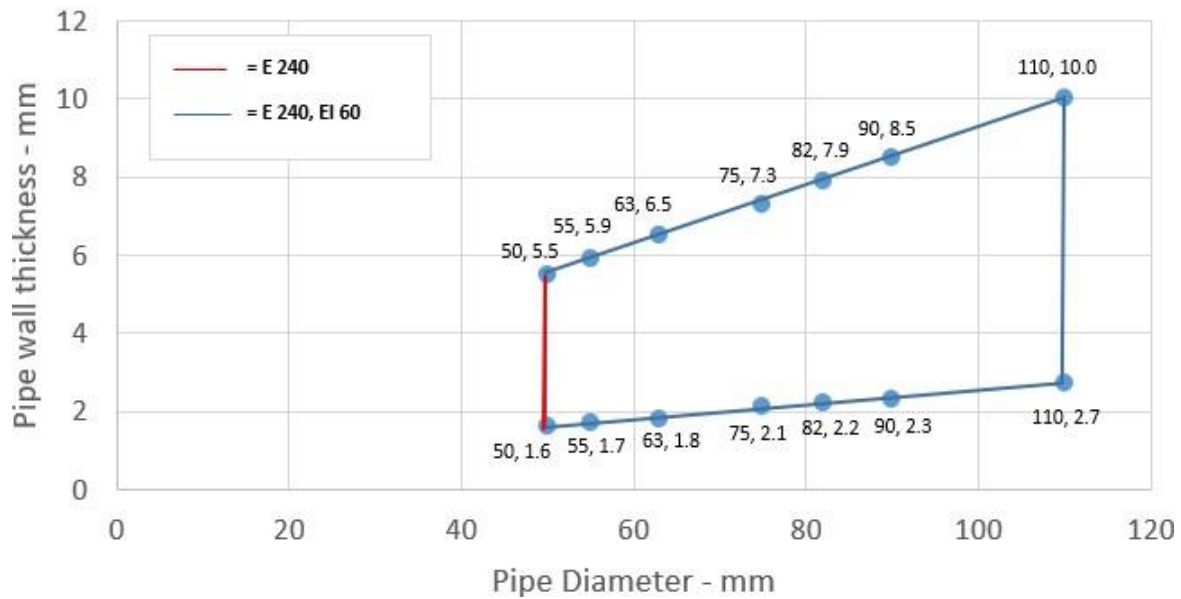

Figure 41 Intermediate pipe wall thicknesses for PP pipe diameters

Table 46 PP pipes (diameters 50 – 110 mm) protected with Protecta FR Collar installed at both sides of a rigid wall

Services	Collar inlay	FRL
PP pipe		
Diameter 50 mm, wall thickness 1.6-5.5 mm*	50 × 3.0 mm	-/240/240 U/U, C/U, U/C, C/C
Diameter 55 mm, wall thickness 1.7-5.6 mm*	50 × 3.2 mm	-/240/90 U/U
Diameter 63 mm, wall thickness 1.8-5.7 mm*	50 × 3.6 mm	
Diameter 75 mm, wall thickness 2.0-5.9 mm*	50 × 4.2 mm	
Diameter 82 mm, wall thickness 2.1-6.0 mm*	50 × 4.6 mm	
Diameter 90 mm, wall thickness 2.3-6.1 mm*	50 × 5.0 mm	
Diameter 110 mm, wall thickness 2.7-6.3 mm	50 × 6.0 mm	
* Typical pipe diameters shown, see below graph for intermediate sizes		

PP pipes 50-110 / 50 mm Collar - U/U

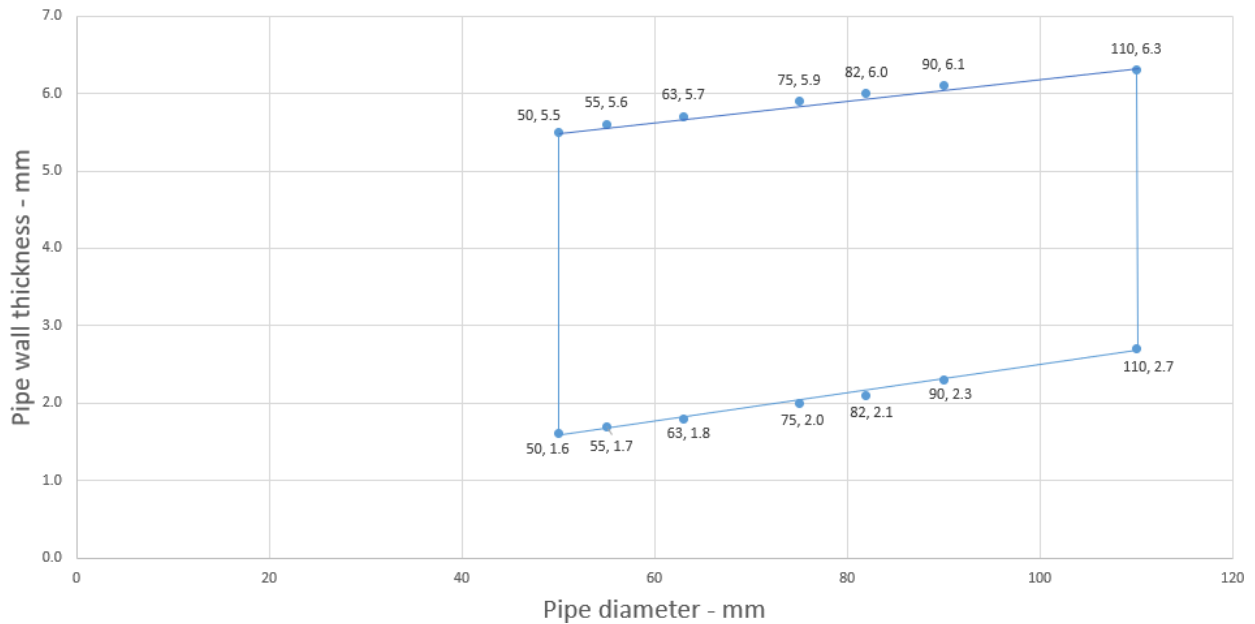

Figure 42 Intermediate pipe wall thicknesses for PP pipe diameters

Table 47 PP pipes (diameters 110 – 160 mm) protected with Protecta FR Collar installed at both sides of a rigid wall

Services	Collar inlay	FRL
PP pipe		
Diameter 110 mm, wall thickness 2.7-10.0 mm*	60 × 6.0 mm	-/240/60 U/U, C/U
Diameter 125 mm, wall thickness 33-11.4 mm*	60 × 8.8 mm	
Diameter 140 mm, wall thickness 4.0-12.8 mm*	60 × 11.5 mm	
Diameter 160 mm, wall thickness 4.9-14.6 mm*	60 × 15.0 mm	-/240/180 U/U, C/U, U/C, C/C
* Typical pipe diameters shown, see below graph for intermediate sizes		

PP Pipes 125-160 / 60 mm Collar - U/U

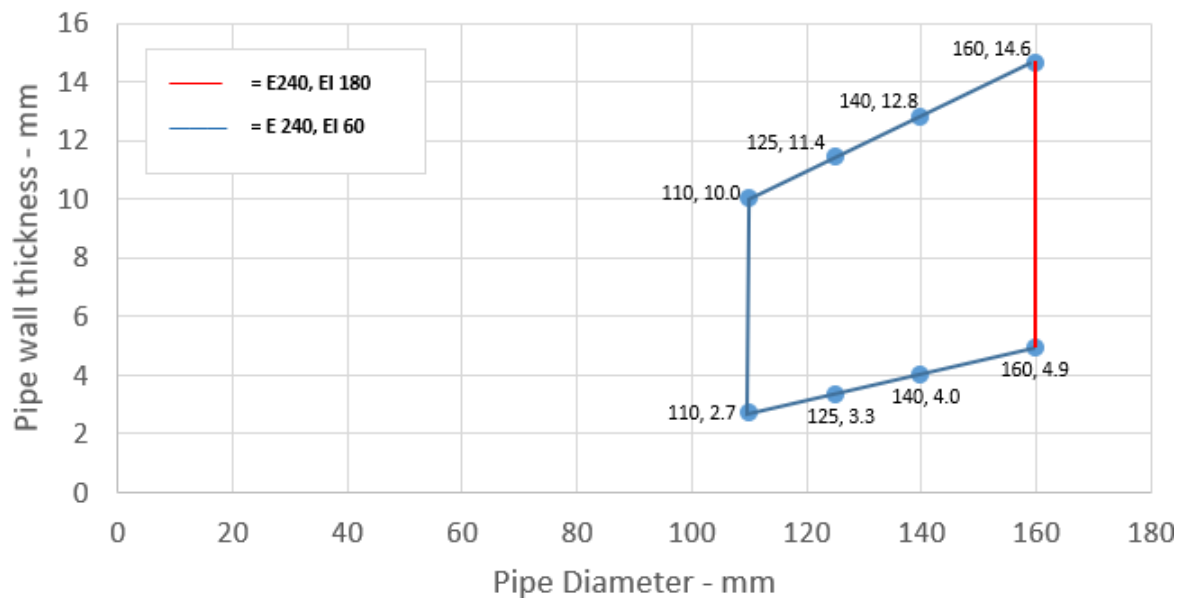

Figure 43 Intermediate pipe wall thicknesses for PP pipe diameters

6.6.2 Penetration seals, in concrete/masonry walls

Penetration seal: Combustible pipes fitted with single Protecta FR Collar, to either side of the wall.

Construction details:

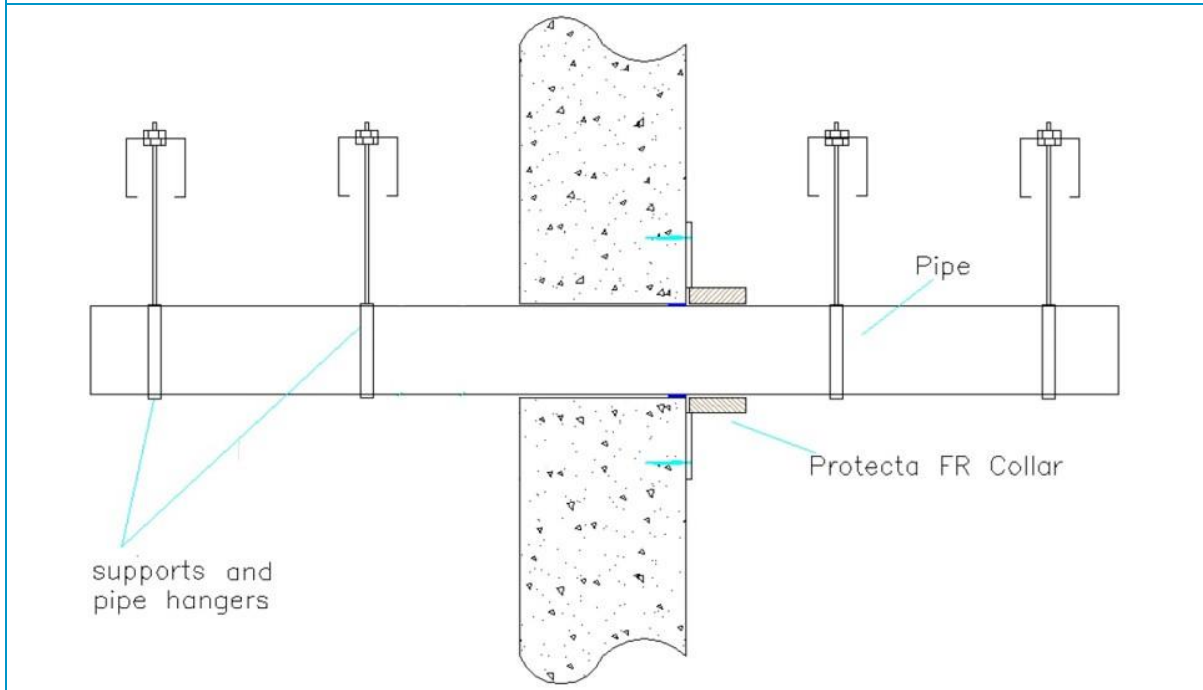

Table 48 Combustible PVC-U pipes protected with single Protecta FR collar

Services	Collar inlay	FRL
PVC-U pipe		
Diameter 32 mm, wall thickness 2.4-3.7 mm	50 × 3.0 mm	-/240/180 U/C, C/C
Diameter 40 mm, wall thickness 2.4-3.7 mm		
Diameter 50 mm, wall thickness 2.4-3.7 mm*		
Diameter 55 mm, wall thickness 2.5-3.9 mm*	50 × 3.2 mm	-/180/120 U/C, C/C
Diameter 63 mm, wall thickness 2.6-4.3 mm*	50 × 3.6 mm	
Diameter 75 mm, wall thickness 2.7-4.9 mm*	50 × 4.2 mm	
Diameter 82 mm, wall thickness 2.8-5.2 mm*	50 × 4.6 mm	
Diameter 90 mm, wall thickness 2.9-5.6 mm*	50 × 5.0 mm	
Diameter 110 mm, wall thickness 3.2-6.6 mm*	50 × 6.0 mm	
Diameter 125 mm, wall thickness 3.4-7.5 mm*	60 × 8.8 mm	-/120/120 U/C, C/C
Diameter 140 mm, wall thickness 3.7-8.3 mm*	60 × 11.5 mm	
Diameter 160 mm, wall thickness 4.0-9.5 mm*	60 × 15.0 mm	
* Typical pipe diameters shown, see below graph for intermediate sizes		

PVC-U Pipes 50-110 / 50 mm Collar

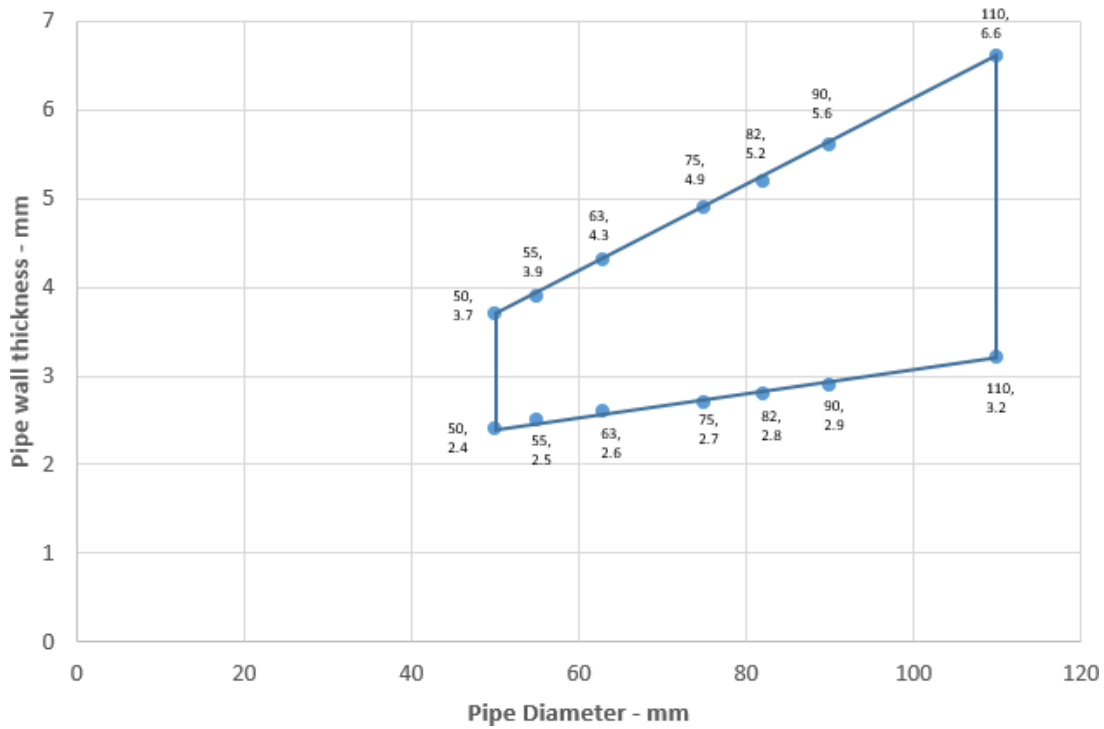

Figure 44 Intermediate pipe wall thicknesses for PVC pipe diameters

PVC-U Pipes 125-160 / 60 mm Collar

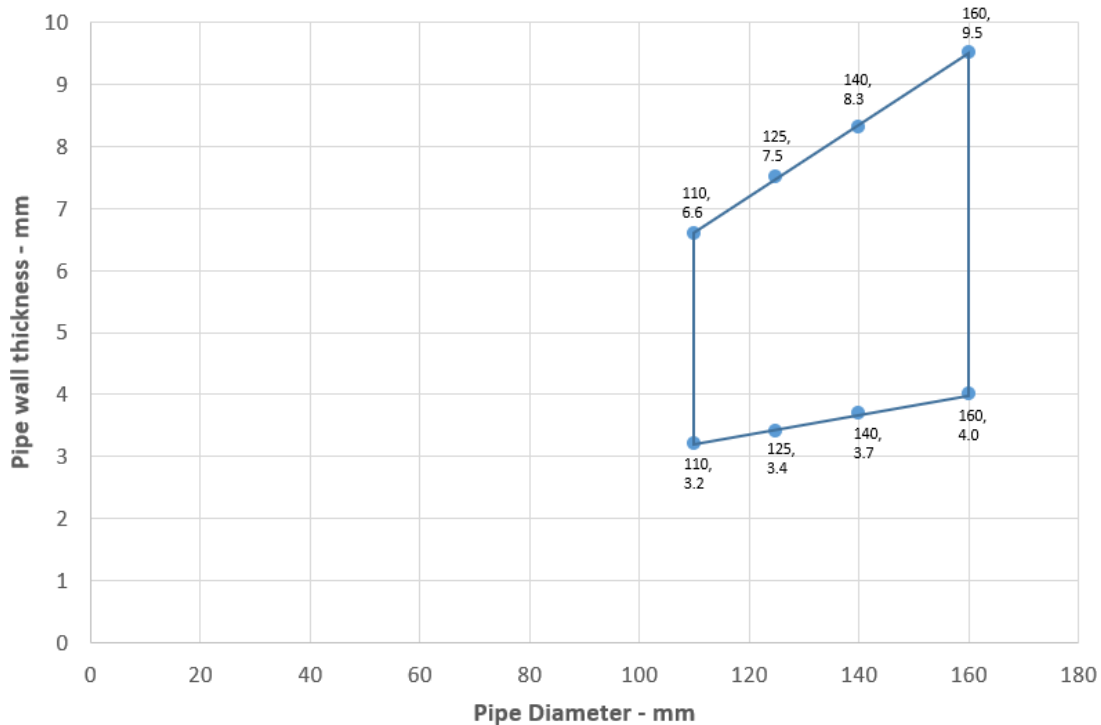

Figure 45 Intermediate pipe wall thicknesses for PVC pipe diameters

Table 49 Combustible PE pipes protected with single Protecta FR collar

Services	Collar inlay	FRL
PE pipe		
Diameter 32 mm, wall thickness 3.0-4.6 mm	50 × 3.0 mm	-/180/120 U/C, C/C
Diameter 40 mm, wall thickness 3.0-4.6 mm		
Diameter 50 mm, wall thickness 3.0-4.6 mm		
Diameter 55 mm, wall thickness 3.1-4.5 mm*	50 × 3.2 mm	-/90/90 U/C, C/C
Diameter 63 mm, wall thickness 3.1-4.3 mm*	50 × 3.6 mm	
Diameter 75 mm, wall thickness 3.2-4.1 mm*	50 × 4.2 mm	
Diameter 82 mm, wall thickness 3.2-3.9 mm*	50 × 4.6 mm	
Diameter 90 mm, wall thickness 3.3-3.8 mm*	50 × 5.0 mm	
Diameter 110 mm, wall thickness 3.4 mm*	50 × 6.0 mm	
* Typical pipe diameters shown, see below graph for intermediate sizes		

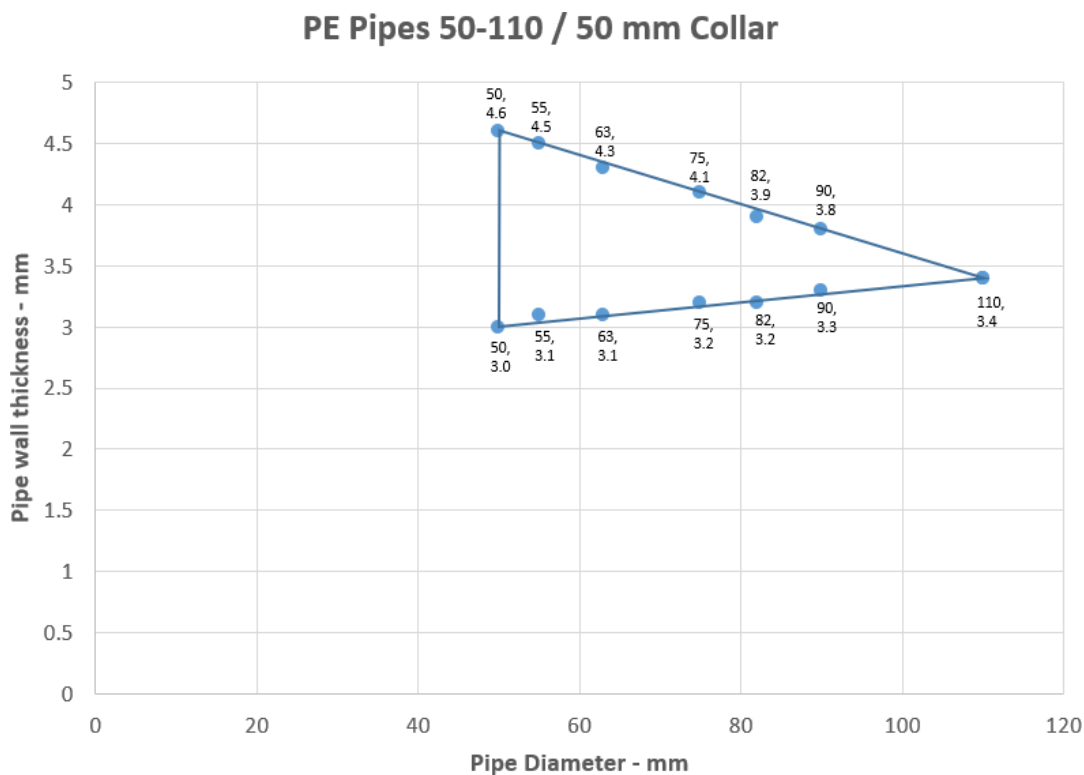

Figure 46 Intermediate pipe wall thicknesses for PE pipe diameters

Table 50 Combustible PP pipes protected with single Protecta FR collar

Services	Collar inlay	FRL
PP pipe		
Diameter 32 mm, wall thickness 2.0-4.6 mm	50 × 3.0 mm	-/90/90 U/C, C/C
Diameter 40 mm, wall thickness 2.0-4.6 mm		
Diameter 50 mm, wall thickness 2.0-4.6 mm		
*Typical pipe diameters shown, see below graph for intermediate sizes		

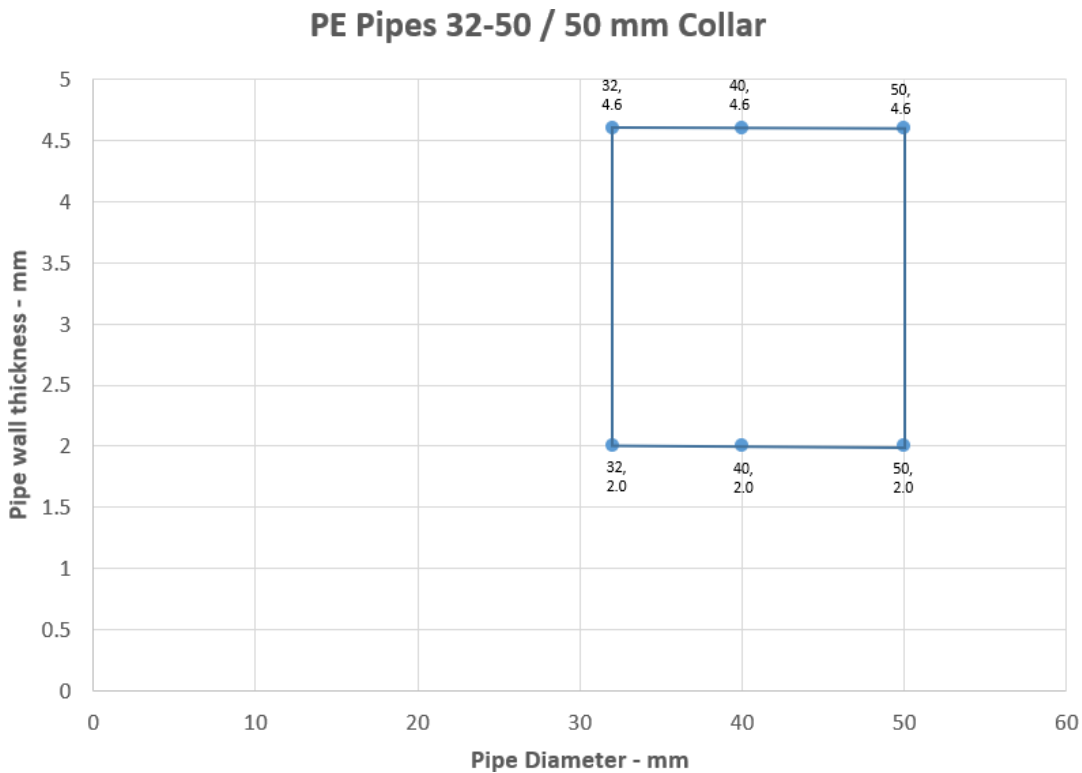

Figure 47 Intermediate pipe wall thicknesses for PE pipe diameters

6.7 Rigid floor constructions with floor thickness of minimum 150 mm

6.7.1 Penetration seals, surface mounted in concrete floors

Penetration seal: Combustible pipes fitted with Protecta FR Collar, to the soffit of the floor.

Construction details:

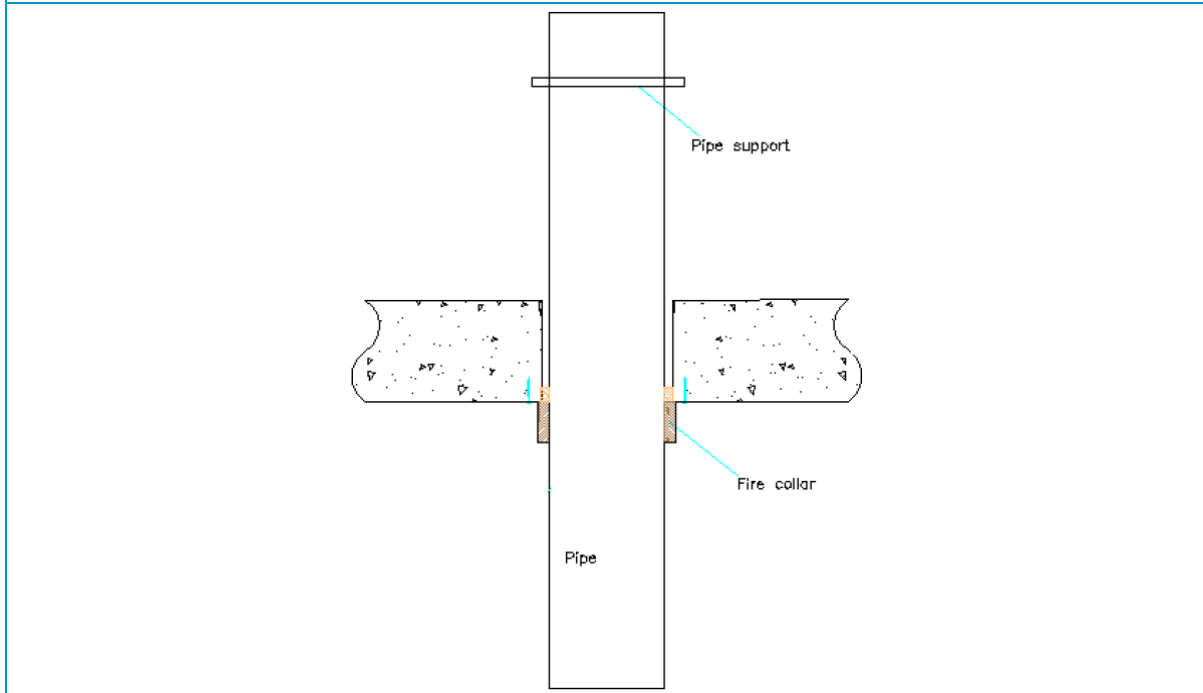

Table 51 PVC-U pipes (diameter 32 – 110 mm) protected with Protecta FR Collar on the exposed side

Services	Collar inlay	FRL
PVC-U pipe		
Diameter 32 mm, wall thickness 1.9-3.7 mm*	30 × 3.0 mm	-/90/60 U/U, C/U, U/C, C/C
Diameter 40 mm, wall thickness 1.9-3.7 mm*		
Diameter 50 mm, wall thickness 2.0-3.7 mm*		
Diameter 55 mm, wall thickness 2.1-3.9 mm*	30 × 3.2 mm	-/60/60 U/U, C/U, U/C, C/C
Diameter 63 mm, wall thickness 2.2-4.3 mm*	30 × 3.6 mm	
Diameter 75 mm, wall thickness 2.5-4.9 mm*	30 × 4.2 mm	
Diameter 82 mm, wall thickness 2.6-5.2 mm*	30 × 4.6 mm	
Diameter 90 mm, wall thickness 2.8-5.6 mm*	30 × 5.0 mm	
Diameter 110 mm, wall thickness 3.2-6.6 mm*	30 × 6.0 mm	
*Typical pipe diameters shown, see below graph for intermediate sizes		

PVC Pipes 32-110 / 30 mm Collar - U/U

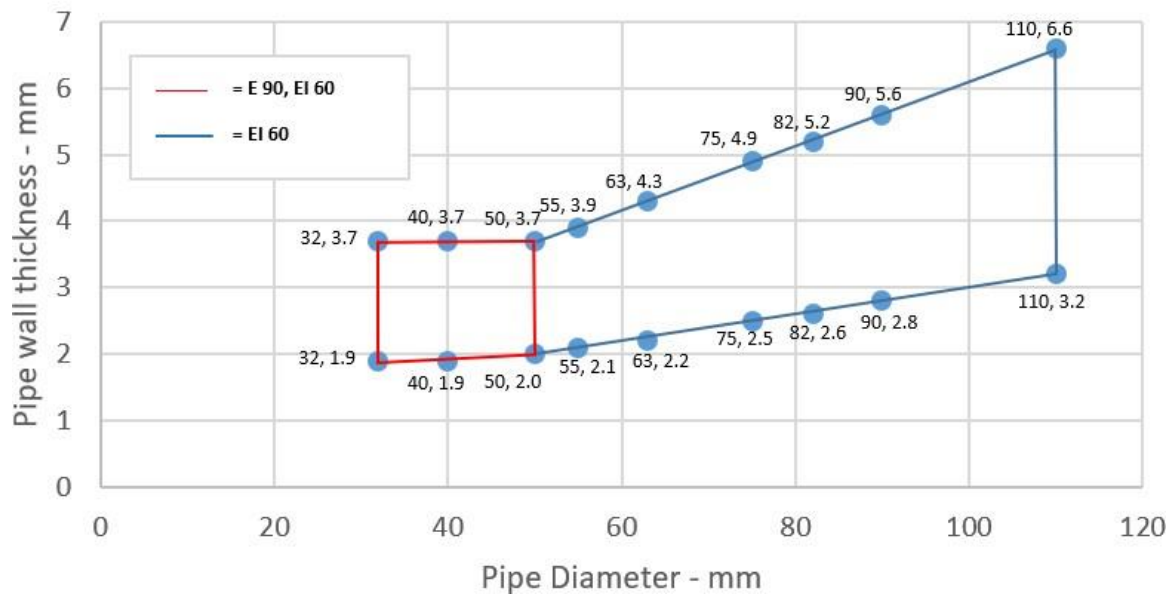

Figure 48 Intermediate pipe wall thicknesses for PVC pipe diameters

Table 52 PVC-U pipes (diameter 32 – 110 mm) protected with Protecta FR Collar on the exposed side

Services	Collar inlay	FRL
PVC-U pipe		
Diameter 32 mm, wall thickness 2.0-3.7 mm	50 × 3.0 mm	-/120/120 U/C, C/C
Diameter 40 mm, wall thickness 2.0-3.7 mm		
Diameter 50 mm, wall thickness 2.0-3.7 mm*		
Diameter 55 mm, wall thickness 2.4-3.9 mm*	50 × 3.2 mm	
Diameter 63 mm, wall thickness 3.0-4.3 mm*	50 × 3.6 mm	
Diameter 75 mm, wall thickness 3.8-4.8 mm*	50 × 4.2 mm	
Diameter 82 mm, wall thickness 4.3-5.1 mm*	50 × 4.6 mm	
Diameter 90 mm, wall thickness 4.9-5.4 mm*	50 × 5.0 mm	
Diameter 110 mm, wall thickness 6.3 mm*	50 × 6.0 mm	
*Typical pipe diameters shown, see below graph for intermediate sizes		

PVC Pipes 50-110 / 50 mm Collar - U/C

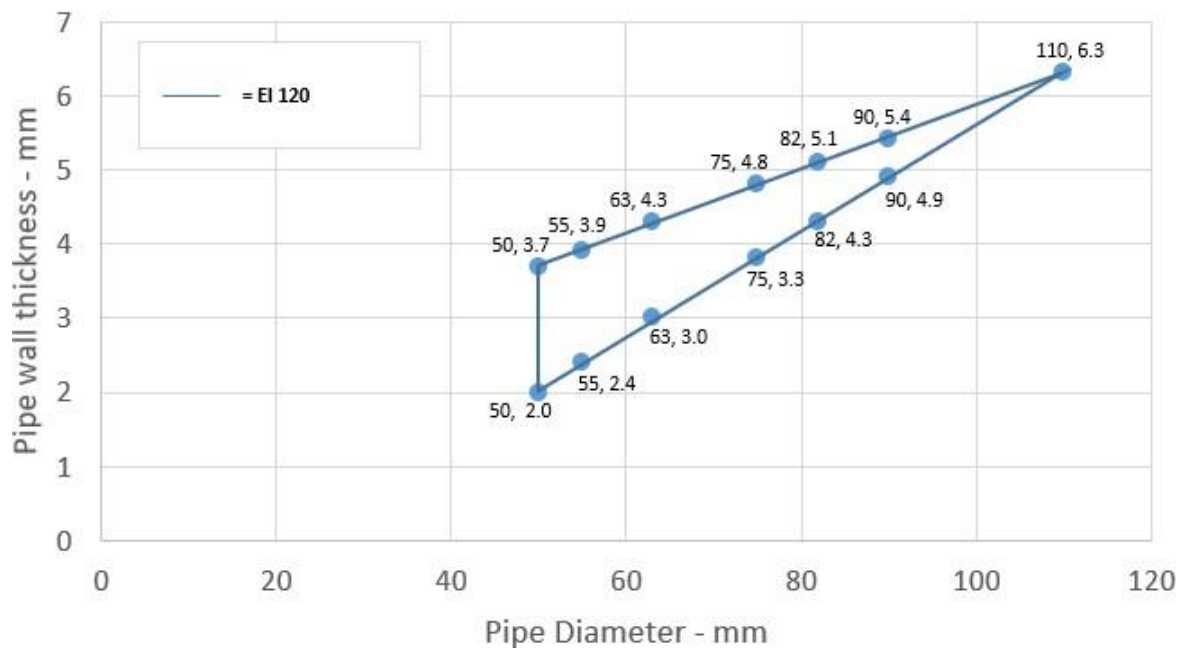

Figure 49 Intermediate pipe wall thicknesses for PVC pipe diameters

Table 53 PVC-U pipes (diameter 50 – 160 mm) protected with Protecta FR Collar on the exposed side

Services	Collar inlay	FRL
PVC-U pipe		
Diameter 50 mm, wall thickness 2.0-3.7 mm*	50 × 3.0 mm	-/120/90 U/C
Diameter 55 mm, wall thickness 2.1-4.0 mm*	50 × 3.2 mm	
Diameter 63 mm, wall thickness 2.2-4.4 mm*	50 × 3.6 mm	
Diameter 75 mm, wall thickness 2.4-5.0 mm*	50 × 4.2 mm	
Diameter 82 mm, wall thickness 2.4-5.4 mm*	50 × 4.6 mm	
Diameter 90 mm, wall thickness 2.5-5.8 mm*	50 × 5.0 mm	
Diameter 110 mm, wall thickness 2.7-6.9 mm*	50 × 6.0 mm	
Diameter 125 mm, wall thickness 2.9-7.6 mm*	50 × 8.8 mm	-/180/90 U/C, C/C
Diameter 140 mm, wall thickness 3.0-8.4 mm*	50 × 11.5 mm	
Diameter 160 mm, wall thickness 3.2-9.5 mm*	50 × 15.0 mm	
Diameter 160 mm, wall thickness 3.2-9.5 mm	50 × 15.0 mm	
*Typical pipe diameters shown, see below graph for intermediate sizes		

PVC Pipes 50-160 / 50 mm Collar - U/C

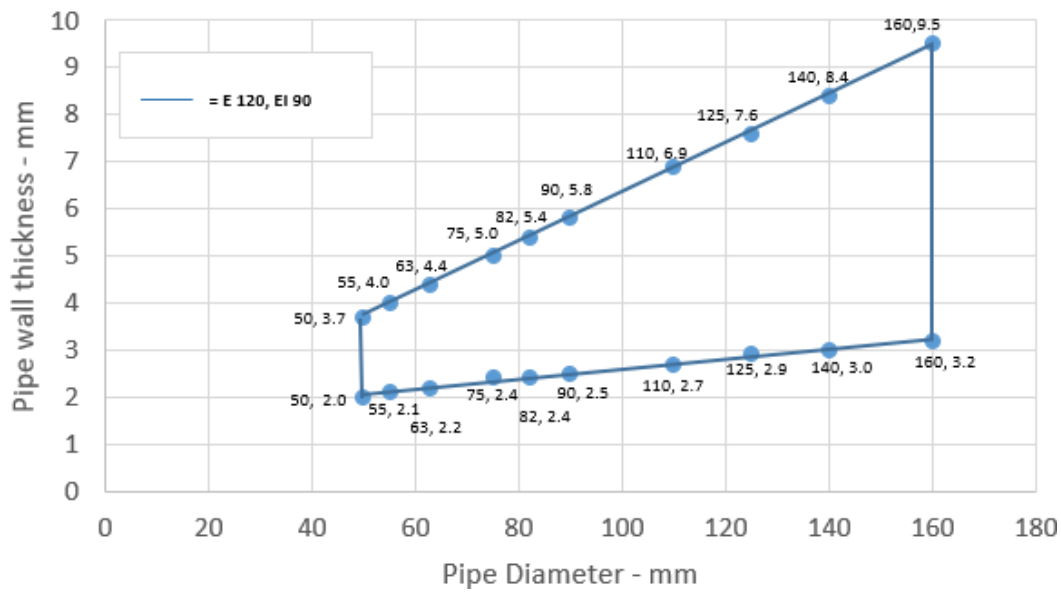

Figure 50 Intermediate pipe wall thicknesses for PVC pipe diameters

Table 54 PVC-U pipes (diameter 110 – 160 mm) protected with Protecta FR Collar on the exposed side

Services	Collar inlay	FRL
PVC-U pipe		
Diameter 110 mm, wall thickness 6.3 mm*	60 × 6.0 mm	-/120/120 U/C, C/C
Diameter 125 mm, wall thickness 5.6-7.3 mm*	60 × 9.0 mm	
Diameter 140 mm, wall thickness 5.0-8.2 mm*	60 × 11.5 mm	
Diameter 160 mm, wall thickness 4.0-9.5 mm*	60 × 15.0 mm	
*Typical pipe diameters shown, see below graph for intermediate sizes		

PVC Pipes 125-160 / 60 mm Collar -U/C

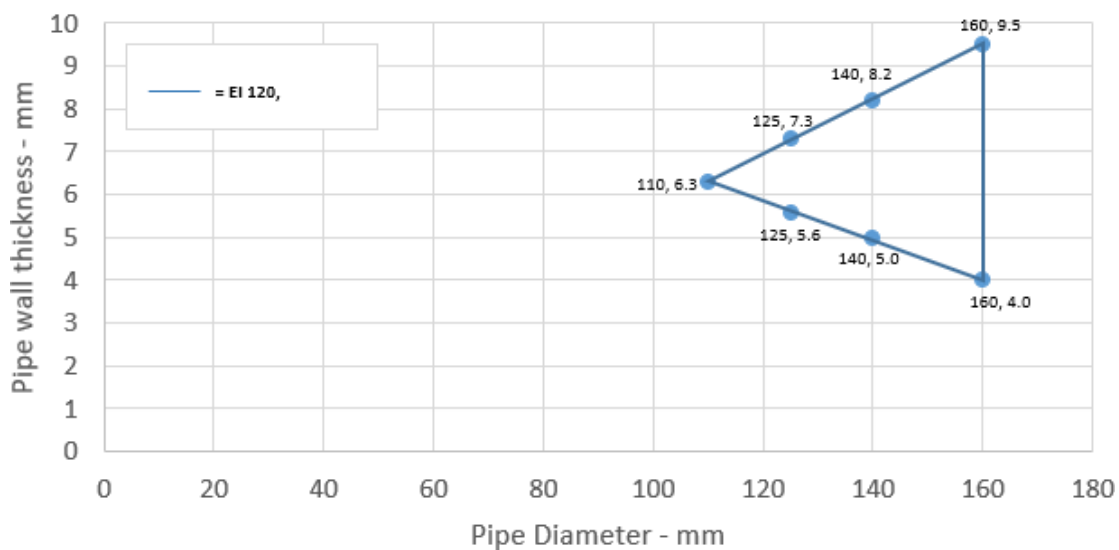

Figure 51 Intermediate pipe wall thicknesses for PVC pipe diameters

Table 55 PVC-U pipes (diameter 110 – 160 mm) protected with Protecta FR Collar on the exposed side

Services	Collar inlay	FRL
PVC-U pipe		
Diameter 110 mm, wall thickness 2.7-6.3 mm*	60 × 6.0 mm	-/60/60 U/C
Diameter 125 mm, wall thickness 2.8-7.2 mm*	60 × 8.7 mm	
Diameter 140 mm, wall thickness 3.0-8.2 mm*	60 × 11.4 mm	
Diameter 160 mm, wall thickness 3.2-9.5 mm*	60 × 15.0 mm	
*Typical pipe diameters shown, see below graph for intermediate sizes		

PVC Pipes 125-160 / 60 mm Collar -U/C

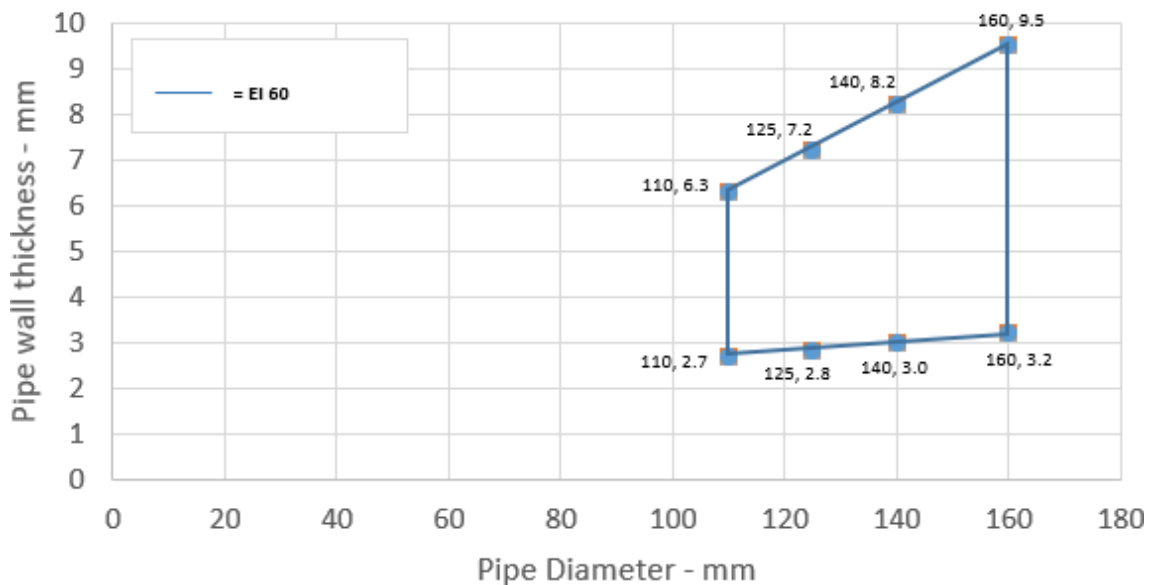

Figure 52 Intermediate pipe wall thicknesses for PVC pipe diameters

Table 56 PVC-U pipes (diameter 110 – 160 mm) protected with Protecta FR Collar on the exposed side

Services	Collar inlay	FRL
PVC-U pipe		
Diameter 110 mm, wall thickness 3.2-6.6 mm*	60 × 6.0 mm	-/60/60 U/U
Diameter 125 mm, wall thickness 3.2-7.4 mm*	60 × 8.7 mm	
Diameter 140 mm, wall thickness 3.2-8.3 mm*	60 × 11.4 mm	
Diameter 160 mm, wall thickness 3.2-9.5 mm*	60 × 15.0 mm	
*Typical pipe diameters shown, see below graph for intermediate sizes		

PVC Pipes 125-160 / 60 mm Collars - U/U

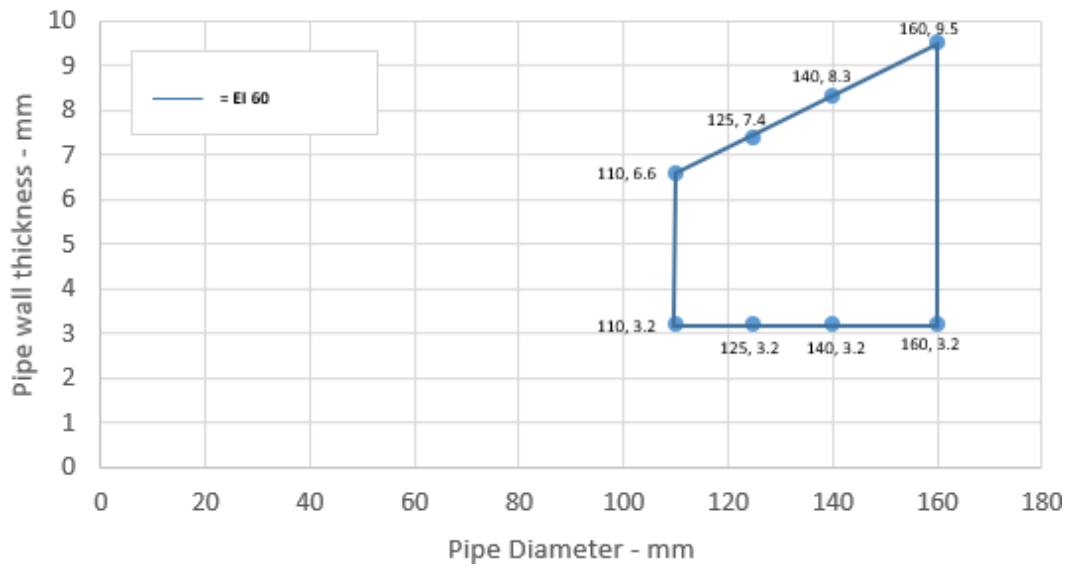

Figure 53 Intermediate pipe wall thicknesses for PVC pipe diameters

Table 57 PVC-U pipes (diameter 110 – 160 mm) protected with Protecta FR Collar on the exposed side

Services	Collar inlay	FRL
PVC-U pipe		
Diameter 110 mm, wall thickness 2.7-6.6 mm*	50 × 6.0 mm	-/60/60 C/U
Diameter 125 mm, wall thickness 2.8-7.4 mm*	60 × 8.7 mm	
Diameter 140 mm, wall thickness 3.0-8.3 mm*	60 × 11.4 mm	
Diameter 160 mm, wall thickness 3.2-9.5 mm*	60 × 15.0 mm	
*Typical pipe diameters shown, see below graph for intermediate sizes		

PVC Pipes 125-160 / 60 mm Collar - C/U

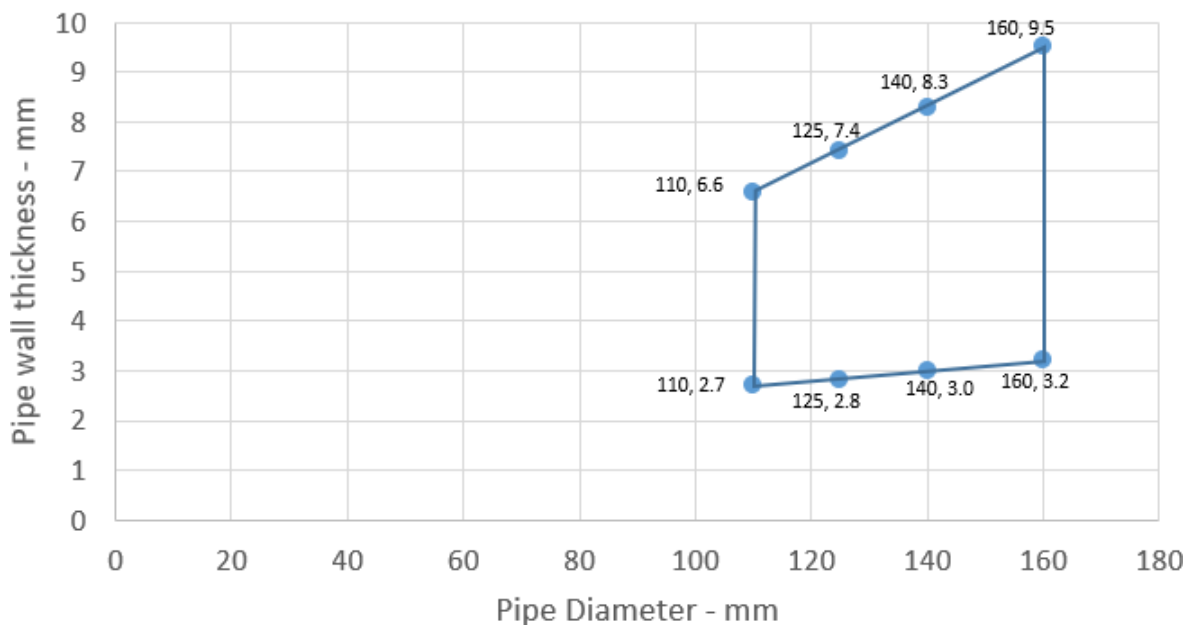

Figure 54 Intermediate pipe wall thicknesses for PVC pipe diameters

Table 58 PE pipes (diameter 32 – 110 mm) protected with Protecta FR Collar on the exposed side

Services	Collar inlay	FRL
PE pipe		
Diameter 32 mm, wall thickness 3.0-4.6 mm*	30 × 3.0 mm	-/60/60 U/U, C/U, U/C, C/C
Diameter 40 mm, wall thickness 3.0-4.6 mm*		
Diameter 50 mm, wall thickness 3.0-4.6 mm*		
Diameter 110 mm, wall thickness 10.0 mm	30 × 6.0 mm	-/180/180 U/C
*Typical pipe diameters shown, see below graph for intermediate sizes		

PE Pipes 32-50 / 30 mm Collar - U/U

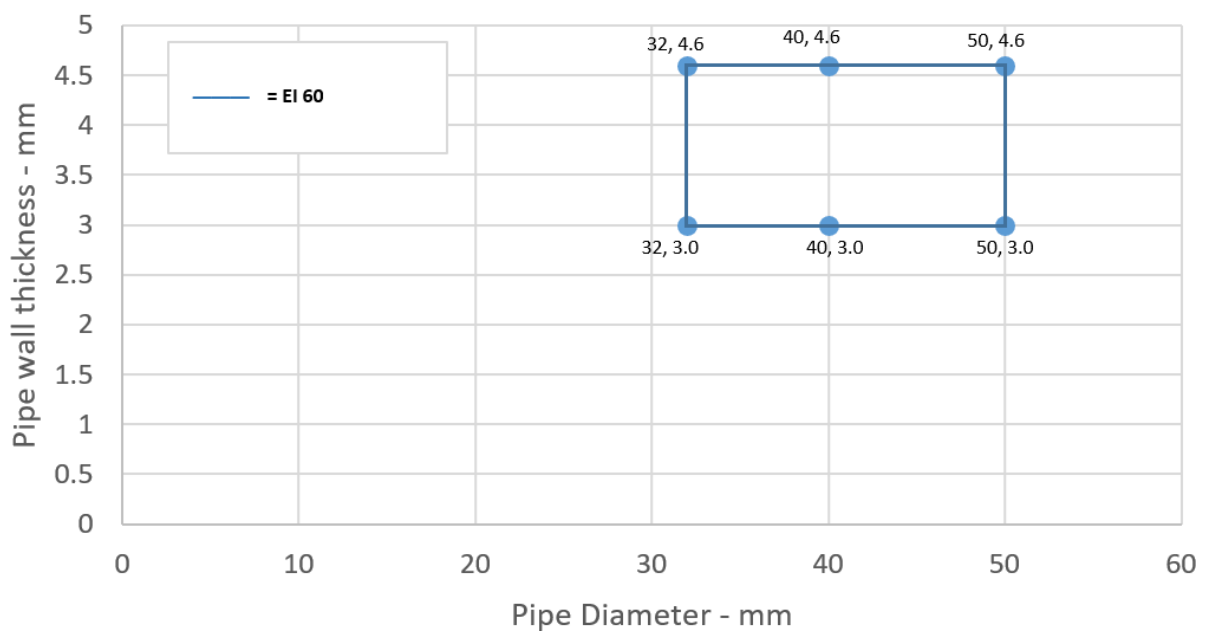

Figure 55 Intermediate pipe wall thicknesses for PE pipe diameters

Table 59 PE pipes (diameter 50 – 110 mm) protected with Protecta FR Collar on the exposed side

Services	Collar inlay	FRL
PE pipe		
Diameter 50 mm, wall thickness 3.0-4.6 mm*	30 × 3.0 mm	-/60/60 U/U, C/U, U/C, C/C
Diameter 55 mm, wall thickness 3.0-5.2 mm*	30 × 3.2 mm	
Diameter 63 mm, wall thickness 3.0-5.9 mm*	30 × 3.6 mm	-/60/60 U/C, C/C
Diameter 75 mm, wall thickness 3.1-6.9 mm*	30 × 4.2 mm	
Diameter 82 mm, wall thickness 3.1-7.6 mm*	30 × 4.6 mm	
Diameter 90 mm, wall thickness 3.2-8.3 mm*	30 × 5.0 mm	
Diameter 110 mm, wall thickness 3.4-10.0 mm*	30 × 6.0 mm	
*Typical pipe diameters shown, see below graph for intermediate sizes		

PE pipes 50-110 / 30 mm Collar - U/C

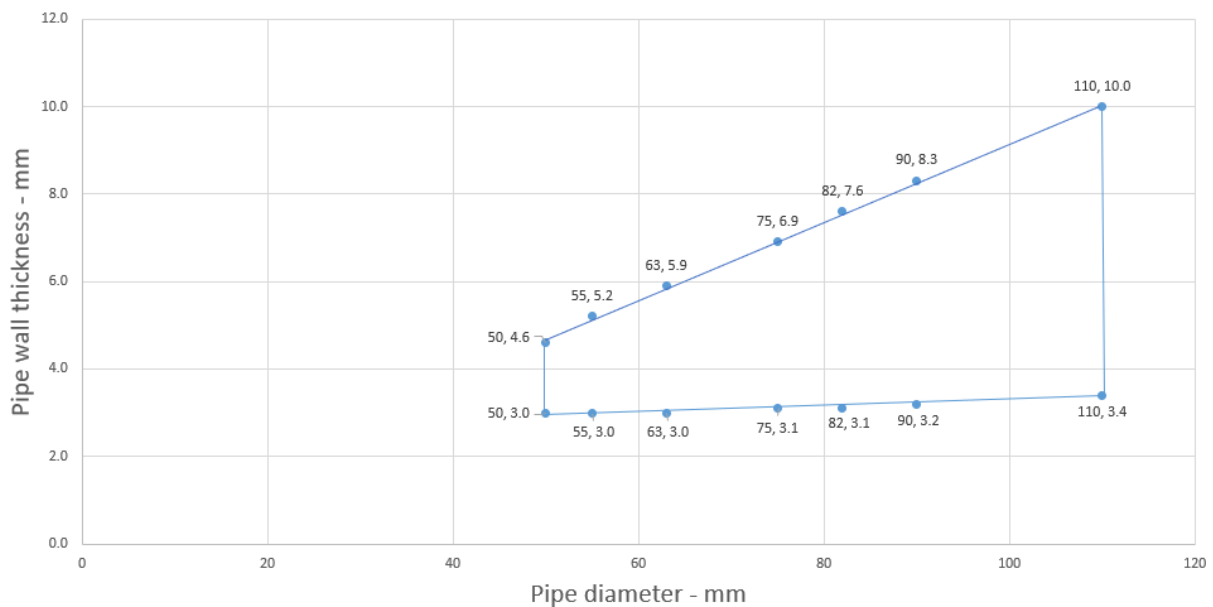

Figure 56 Intermediate pipe wall thicknesses for PE pipe diameters

Table 60 PE pipes (diameter 32 – 110 mm) protected with Protecta FR Collar on the exposed side

Services	Collar inlay	FRL	
PE pipe			
Diameter 32-40 mm, wall thickness 3.0-4.6 mm	50 × 3.0 mm	-/240/240 U/C	
Diameter 50 mm, wall thickness 3.0-4.6 mm	50 × 3.2 mm		
Diameter 32-40 mm, wall thickness 3.0 mm	50 × 3.0 mm	-/240/240 U/U	
Diameter 50 mm, wall thickness 3.0 mm	50 × 3.2 mm		
Diameter 50 mm, wall thickness 3.0-4.6 mm*	50 × 3.0 mm	-/60/60 U/U, C/U	
Diameter 55 mm, wall thickness 3.1-5.1 mm*	50 × 3.2 mm		
Diameter 63 mm, wall thickness 3.1-5.8 mm*	50 × 3.6 mm		
Diameter 75 mm, wall thickness 3.2-6.9 mm*	50 × 4.2 mm		
Diameter 82 mm, wall thickness 3.3-7.5 mm*	50 × 4.6 mm		
Diameter 90 mm, wall thickness 3.3-8.2 mm*	50 × 5.0 mm		
Diameter 110 mm, wall thickness 3.4-10.0 mm*	50 × 6.0 mm		
*Typical pipe diameters shown, see below graph for intermediate sizes			

PE Pipes 50-110 / 50 mm Collar - U/U

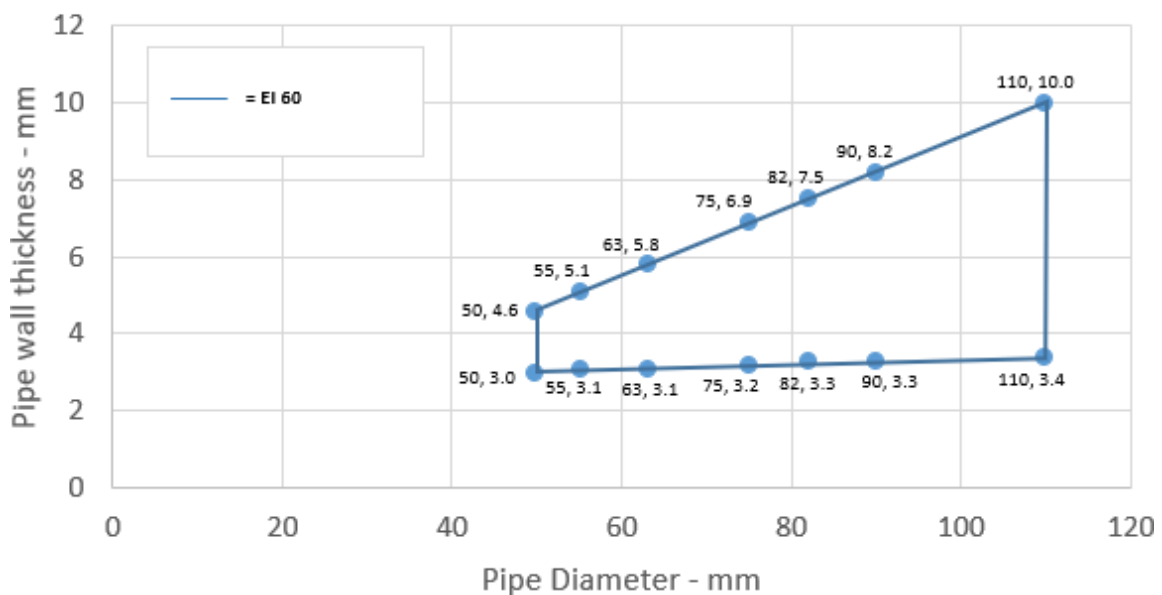

Figure 57 Intermediate pipe wall thicknesses for PE pipe diameters

Table 61 PE pipes (diameter 110 – 160 mm) protected with Protecta FR Collar on the exposed side

Services	Collar inlay	FRL
PE pipe		
Diameter 110 mm, wall thickness 3.4-10.0 mm*	60 × 6.0 mm	-/60/60 U/U, C/U
Diameter 125 mm, wall thickness 3.9-11.3 mm*	60 × 8.8 mm	
Diameter 140 mm, wall thickness 4.3-12.7 mm*	60 × 11.5 mm	
Diameter 160 mm, wall thickness 4.9-14.6 mm*	60 × 15.0 mm	
*Typical pipe diameters shown, see below graph for intermediate sizes		

PE Pipes 125-160 / 60 mm Collar - U/U

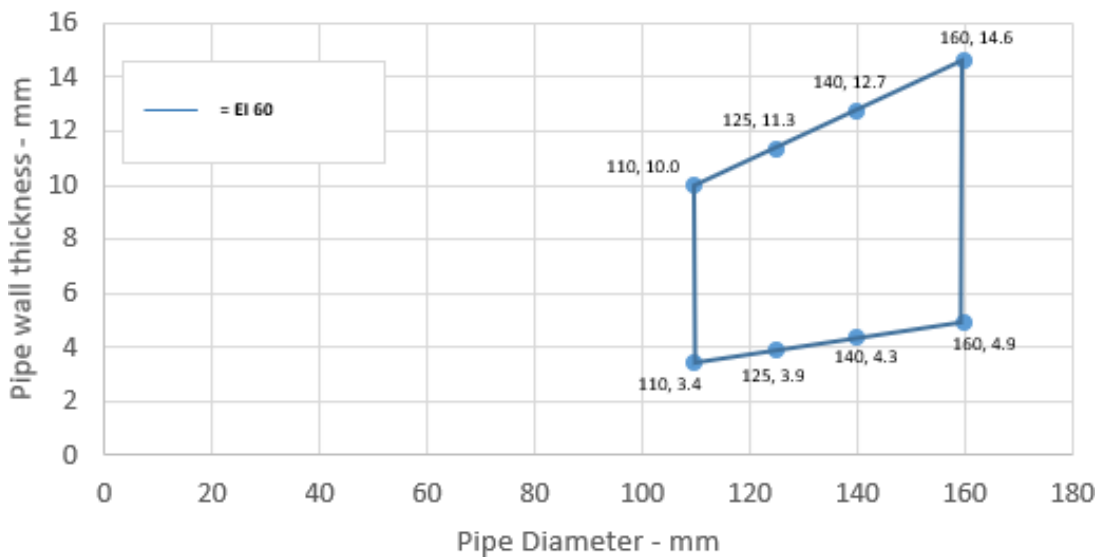

Figure 58 Intermediate pipe wall thicknesses for PE pipe diameters

Table 62 PE pipes (diameter 110 – 160 mm) protected with Protecta FR Collar on the exposed side

Services	Collar inlay	FRL
PE pipe		
Diameter 32 mm, wall thickness 3.0-4.6 mm	50 × 3.0 mm	-/120/120 U/C, C/C
Diameter 40 mm, wall thickness 3.0-4.6 mm		
Diameter 50 mm, wall thickness 3.0-4.6 mm		
Diameter 55 mm, wall thickness 3.1-5.0 mm	50 × 3.2 mm	
Diameter 63 mm, wall thickness 3.1-5.8 mm	50 × 3.6 mm	
Diameter 75 mm, wall thickness 3.2-6.9 mm	50 × 4.2 mm	
Diameter 82 mm, wall thickness 3.3-7.5 mm	50 × 4.6 mm	
Diameter 90 mm, wall thickness 3.3-8.2 mm	50 × 5.0 mm	
Diameter 110 mm, wall thickness 3.4-10.0 mm	50 × 6.0 mm	
Diameter 125 mm, wall thickness 3.9-11.3 mm	50 × 8.8 mm	
Diameter 140 mm, wall thickness 4.4-12.7 mm	50 × 11.5 mm	
Diameter 160 mm, wall thickness 4.9-14.7 mm	50 × 15.0 mm	
*Typical pipe diameters shown, see below graph for intermediate sizes		

PE Pipes 32-16 / 50 mm Collar - U/C

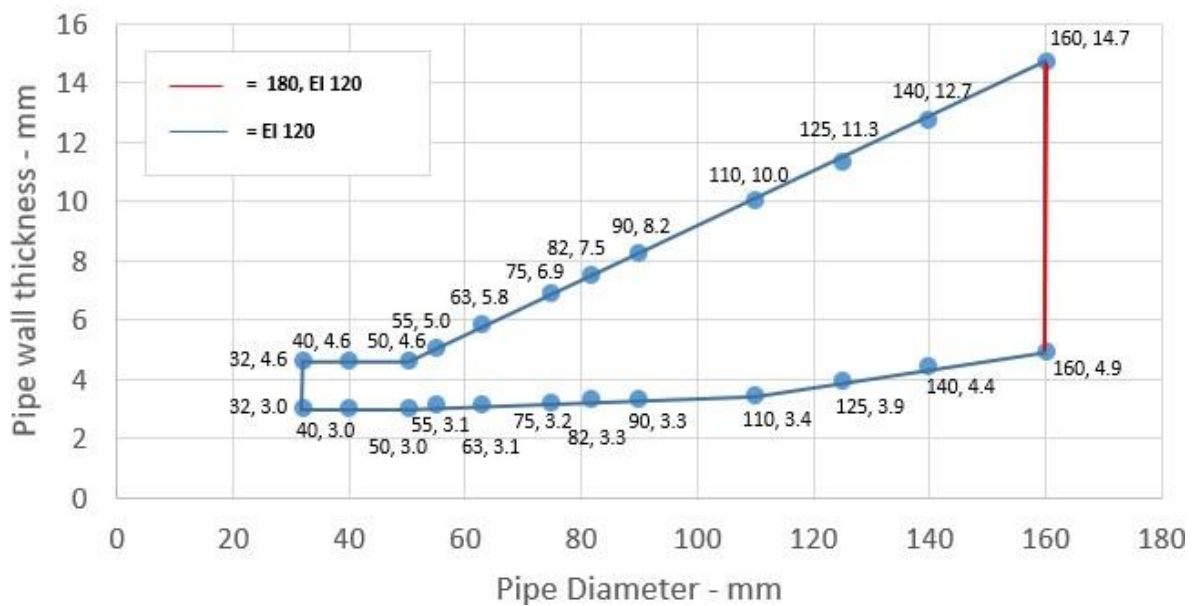

Figure 59 Intermediate pipe wall thicknesses for PE pipe diameters

Table 63 PP pipes (diameter 32 – 110 mm) protected with Protecta FR Collar on the exposed side

Services	Collar inlay	FRL
PP pipe		
Diameter 32 mm, wall thickness 1.8-4.6 mm*	30 × 3.0 mm	-120/120 U/U, C/U, U/C, C/C
Diameter 40 mm, wall thickness 1.8-4.6 mm*		
Diameter 50 mm, wall thickness 1.8-4.6 mm*		
Diameter 55 mm, wall thickness 2.0-4.8 mm*	30 × 3.2 mm	-120/120 U/C, C/C
Diameter 63 mm, wall thickness 2.3-5.5 mm*	30 × 3.6 mm	
Diameter 75 mm, wall thickness 2.8-5.4 mm*	30 × 4.2 mm	
Diameter 82 mm, wall thickness 3.1-5.6 mm*	30 × 4.6 mm	
Diameter 90 mm, wall thickness 3.4-5.9 mm*	30 × 5.0 mm	
Diameter 110 mm, wall thickness 4.2-6.6 mm*	30 × 6.0 mm	
*Typical pipe diameters shown, see below graph for intermediate sizes		

PP Pipes 32-50 / 30 mm Collar - U/U

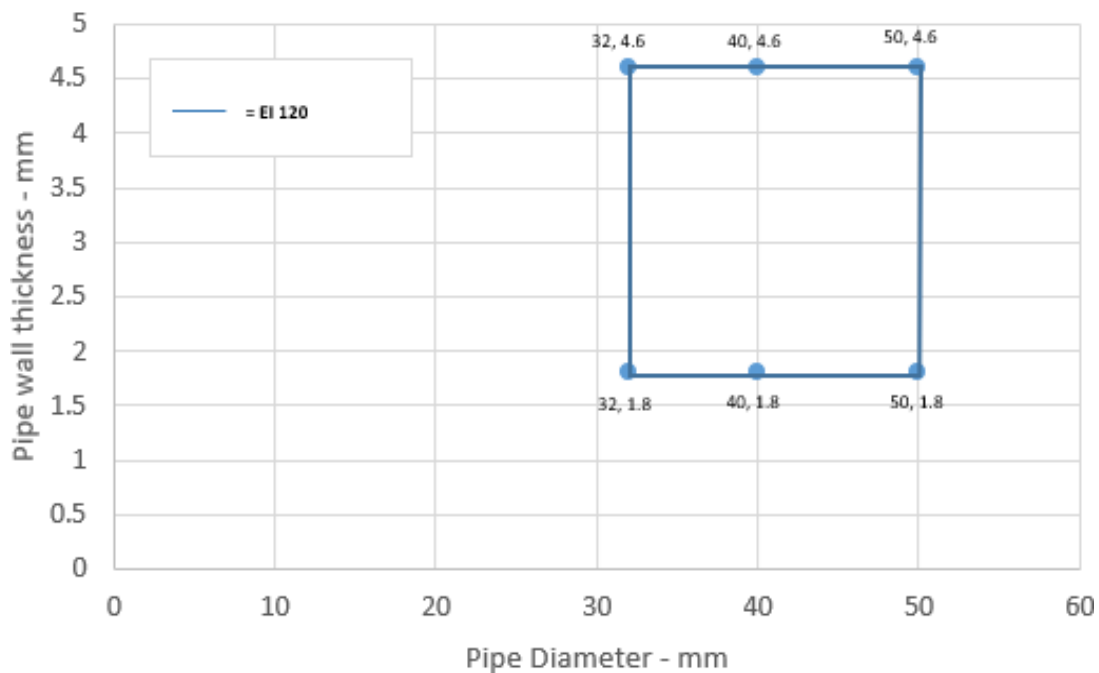

Figure 60 Intermediate pipe wall thicknesses for PP pipe diameters

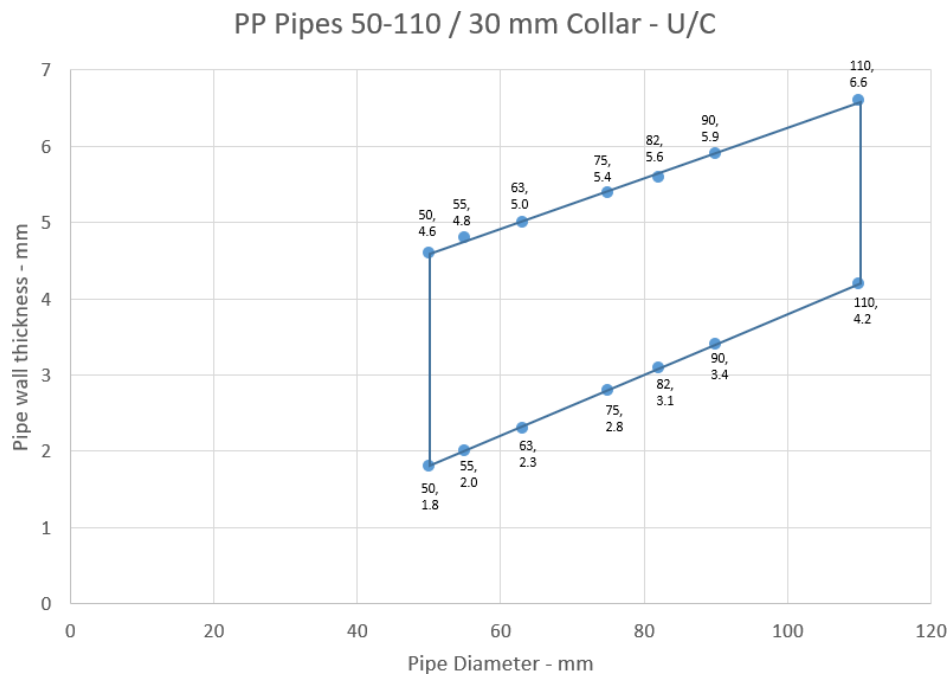

Figure 61 Intermediate pipe wall thicknesses for PP pipe diameters

Table 64 PP pipes (diameter 50 – 110 mm) protected with Protecta FR Collar on the exposed side

Services	Collar inlay	FRL
PP pipe		
Diameter 50 mm, wall thickness 2.9 mm	50 × 3.2 mm	-/240/240 U/U
Diameter 50 mm, wall thickness 1.8-4.6 mm*	50 × 3.0 mm	-/120/120 U/U, C/U, U/C, C/C
Diameter 55 mm, wall thickness 1.9-4.8 mm*	50 × 3.2 mm	-/60/60 U/U, C/U
Diameter 63 mm, wall thickness 2.0-5.0 mm*	50 × 3.6 mm	
Diameter 75 mm, wall thickness 2.2-5.4 mm*	50 × 4.2 mm	
Diameter 82 mm, wall thickness 2.3-5.6 mm*	50 × 4.6 mm	
Diameter 90 mm, wall thickness 2.4-5.9 mm*	50 × 5.0 mm	
Diameter 110 mm, wall thickness 2.7-6.6 mm*	50 × 6.0 mm	
*Typical pipe diameters shown, see below graph for intermediate sizes		

PP Pipes 55-110 / 50 mm Collar - U/U

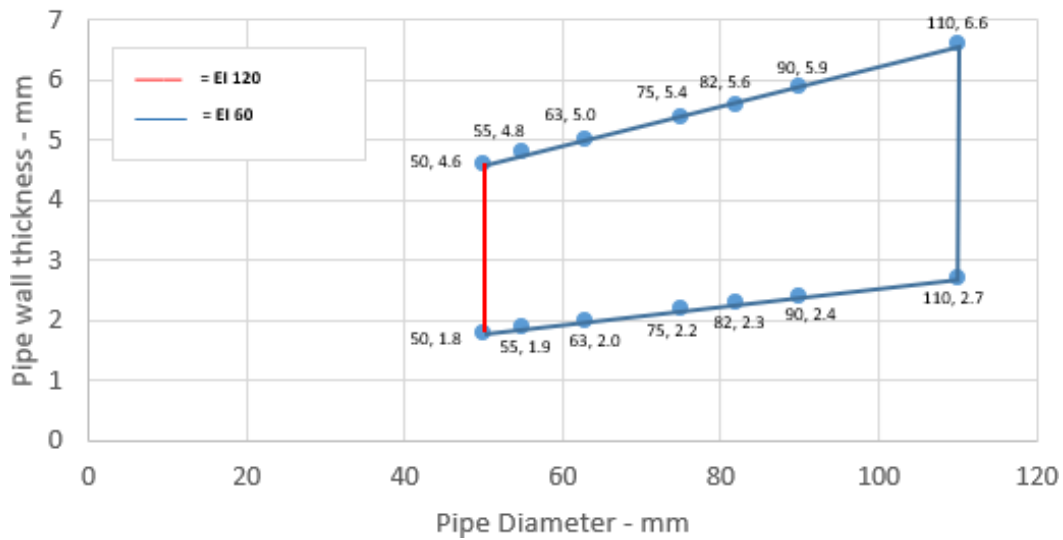

Figure 62 Intermediate pipe wall thicknesses for PP pipe diameters

Table 65 PP pipes (diameter 50 – 110 mm) protected with Protecta FR Collar on the exposed side

Services	Collar inlay	FRL
PP pipe		
Diameter 50 mm, wall thickness 1.8-4.6 mm*	50 × 3.0 mm	-/120/120 U/U U/U, C/U, U/C, C/C
Diameter 55 mm, wall thickness 1.9-4.8 mm*	50 × 3.2 mm	-/120/120 U/C, C/C
Diameter 63 mm, wall thickness 2.0-5.0 mm*	50 × 3.6 mm	
Diameter 75 mm, wall thickness 2.2-5.4 mm*	50 × 4.2 mm	
Diameter 82 mm, wall thickness 2.3-5.6 mm*	50 × 4.6 mm	
Diameter 90 mm, wall thickness 2.4-5.9 mm*	50 × 5.0 mm	
Diameter 110 mm, wall thickness 2.7-6.6 mm*	50 × 6.0 mm	
*Typical pipe diameters shown, see below graph for intermediate sizes		

PP Pipes 55-110 / 50 mm Collar - U/C

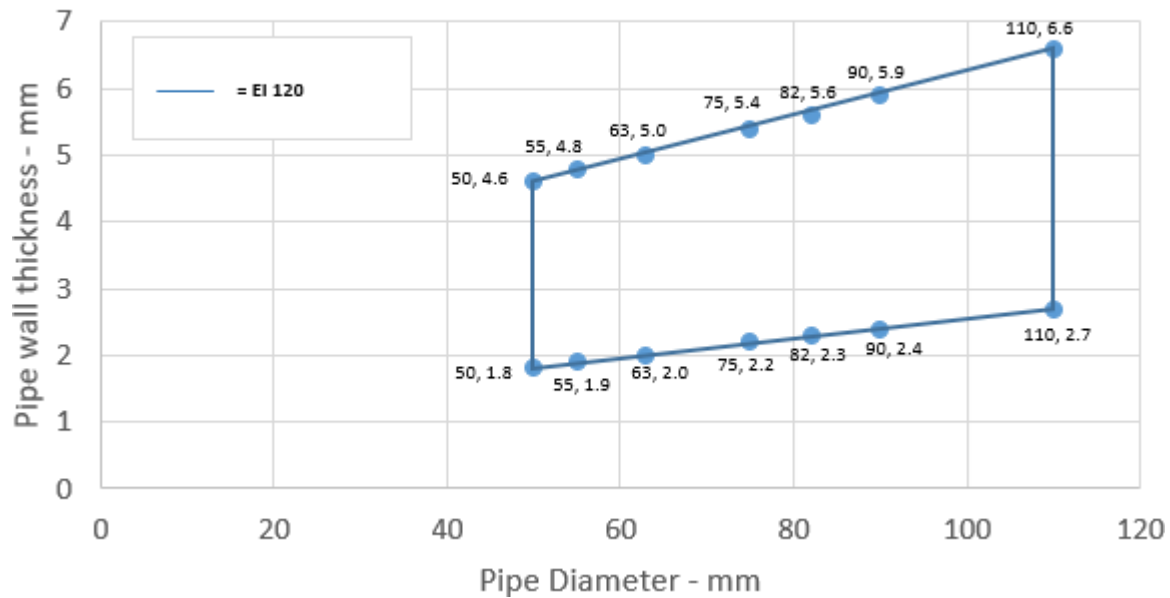

Figure 63 Intermediate pipe wall thicknesses for PP pipe diameters

Table 66 PP pipes (diameter 50 – 160 mm) protected with Protecta FR Collar on the exposed side

Services	Collar inlay	FRL
PP pipe		
Diameter 50 mm, wall thickness 1.8-4.6 mm*	30 × 3.0 mm	-/60/60 U/C, C/C
Diameter 55 mm, wall thickness 1.9-5.1 mm*	50 × 3.2 mm	
Diameter 63 mm, wall thickness 2.0-5.8 mm*	50 × 3.6 mm	
Diameter 75 mm, wall thickness 2.2-6.9 mm*	50 × 4.2 mm	
Diameter 82 mm, wall thickness 2.3-7.5 mm*	50 × 4.6 mm	
Diameter 90 mm, wall thickness 2.5-8.2 mm*	50 × 5.0 mm	
Diameter 110 mm, wall thickness 2.7-10.1 mm*	50 × 6.0 mm	
Diameter 125 mm, wall thickness 4.7-11.4 mm*	50 × 8.8 mm	
Diameter 140 mm, wall thickness 6.8-12.8 mm*	50 × 11.5 mm	
Diameter 160 mm, wall thickness 9.5-14.6 mm*	50 × 15.0 mm	
*Typical pipe diameters shown, see below graph for intermediate sizes		

PP Pipes 55-160 / 50 mm Collar - U/C

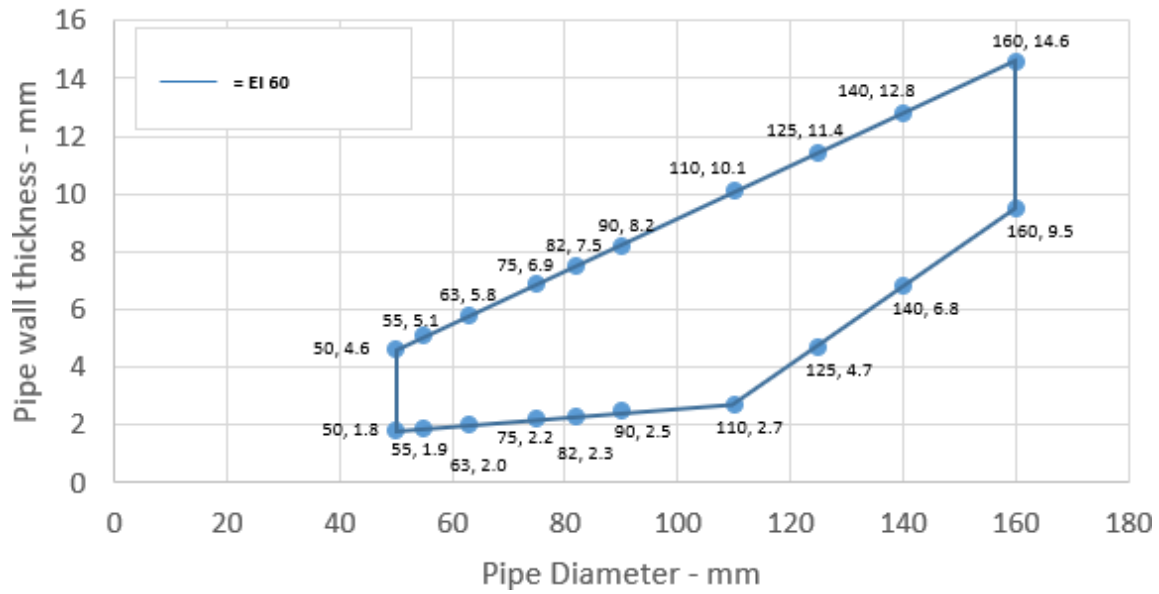

Figure 64 Intermediate pipe wall thicknesses for PP pipe diameters

Table 67 PP pipes (diameter 110 – 160 mm) protected with Protecta FR Collar on the exposed side

Services	Collar inlay	FRL
PP pipe		
Diameter 110 mm, wall thickness 2.7-6.6 mm*	60 × 6.0 mm	-/120/120 U/C, C/C
Diameter 125 mm, wall thickness 3.4-8.9 mm*	60 × 8.8 mm	
Diameter 140 mm, wall thickness 4.1-11.2 mm*	60 × 11.5 mm	
Diameter 160 mm, wall thickness 4.9-14.6 mm*	60 × 15.0 mm	-/180/180 U/C, C/C
*Typical pipe diameters shown, see below graph for intermediate sizes		

PP Pipes 125-160 / 60 mm Collar - U/C

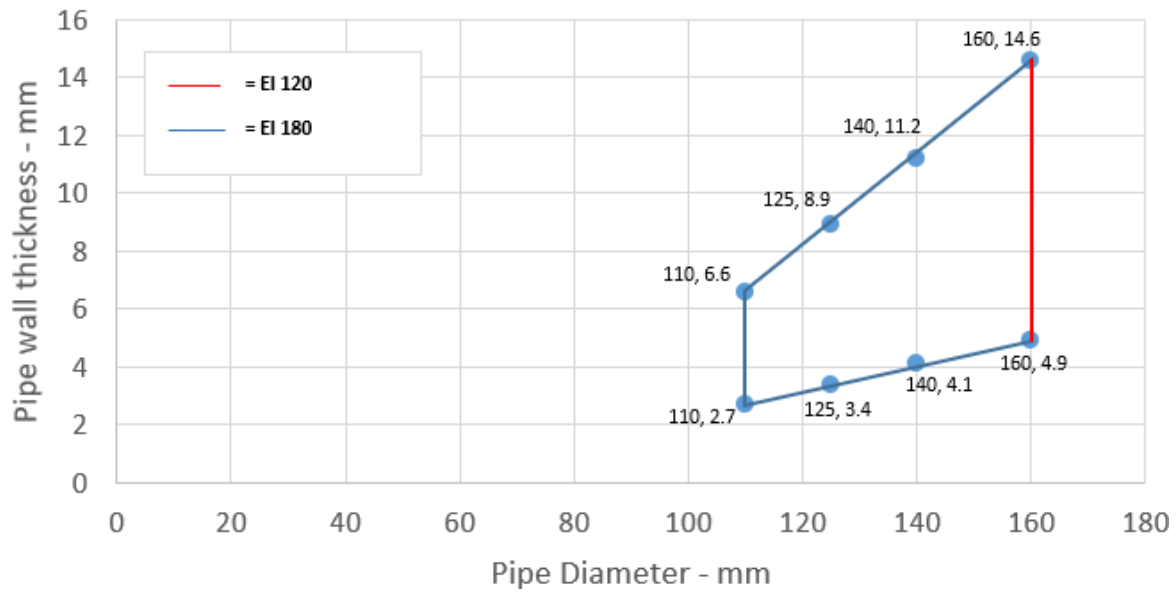

Figure 65 Intermediate pipe wall thicknesses for PP pipe diameters

Table 68 PP pipes (diameter 110 – 160 mm) protected with Protecta FR Collar on the exposed side

Services	Collar inlay	FRL
PP pipe		
Diameter 110 mm, wall thickness 2.7-6.6 mm*	50 × 6.0 mm	-/60/60 U/U
Diameter 125 mm, wall thickness 3.6-8.9 mm*	60 × 8.8 mm	
Diameter 140 mm, wall thickness 4.7-11.3 mm*	60 × 11.5 mm	
Diameter 160 mm, wall thickness 6.2-14.7 mm*	60 × 15.0 mm	
Diameter 160 mm, wall thickness 6.2 mm	60 × 15.0 mm	-/90/90 U/U
*Typical pipe diameters shown, see below graph for intermediate sizes		

PP Pipes 125-160 / 60 mm Collar - U/U

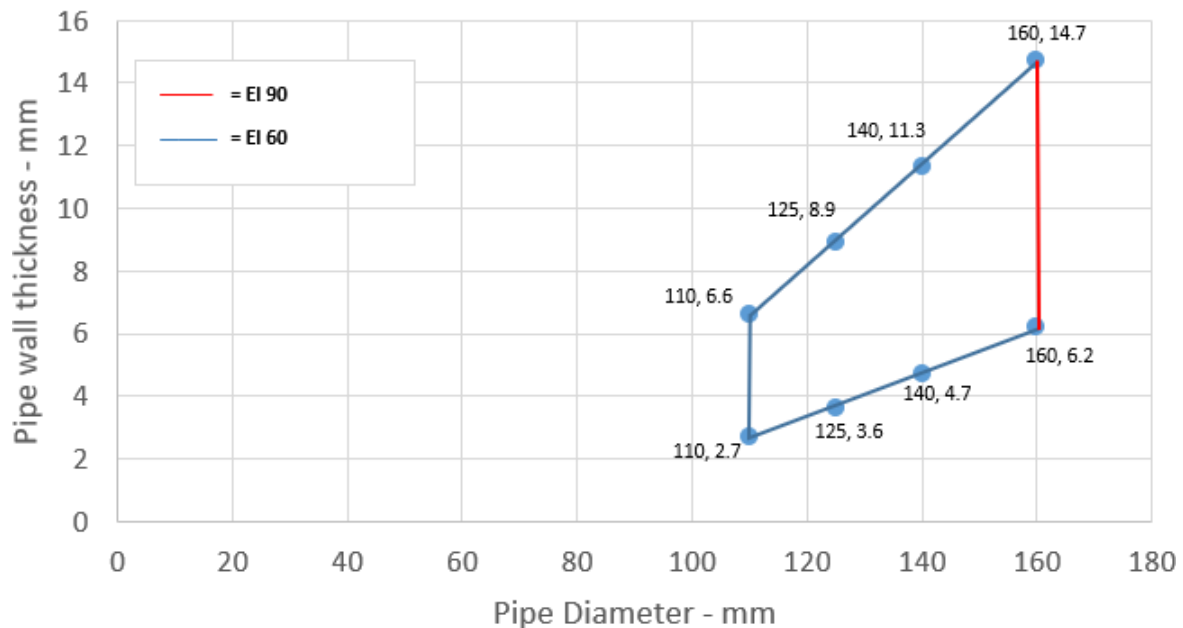

Figure 66 Intermediate pipe wall thicknesses for PP pipe diameters

Table 69 Pipes protected with Protecta FR Collar on the exposed side

Services	Collar inlay	FRL
Wavin SiTech + PP-M B		
32-40 mm diameter/ 1.8 mm wall thickness	50 × 3.0 mm	-/240/240 U/U
50 mm diameter/ 1.8 mm wall thickness	50 × 3.2 mm	
75 mm diameter/ 1.8-2.5 mm wall thickness	50 × 4.2 mm	-/180/180 C/U
90 mm diameter/ 1.8-2.9 mm wall thickness	50 × 5.0 mm	
110 mm diameter/ 1.8-3.4 mm wall thickness	50 × 6.0 mm	
Aquatherm Green SDR9 MF PP-RP		
32 mm diameter/3.6-5.6 mm wall thickness	30 × 3.0 mm	-/240/240 C/C
40 mm diameter/3.6-5.6 mm wall thickness	50 × 3.0 mm	
50 mm diameter/3.6-5.6 mm wall thickness	50 × 3.2 mm	
63 diameter/5.6-12.3 mm wall thickness	50 × 3.6 mm	-/120/120 C/C
75 diameter/4.4-8.4 mm wall thickness	50 × 4.2 mm	
90 diameter/4.9-10.0 mm wall thickness	50 × 5.0 mm	
110 diameter/5.6-12.3 mm wall thickness	50 × 6.0 mm	
Geberit Silent PP		
32-40 mm diameter/ 1.8 mm wall thickness	50 × 3.0 mm	-/240/240 U/U
50 mm diameter/ 1.8 mm wall thickness	50 × 3.2 mm	
75 mm diameter/1.8-2.4 mm wall thickness	50 × 4.2 mm	-/180/180 C/U
90 mm diameter/1.8-2.8 mm wall thickness	50 × 5.0 mm	
110 mm diameter/1.8-3.4 mm wall thickness	50 × 6.0 mm	
Polo-Kal NG Poloplast PP-MV		

Services	Collar inlay	FRL
32-40 mm diameter/1.8-2.0 mm wall thickness	50 × 3.0 mm	-/240/240 U/U
50 mm diameter/1.8-2.0 mm wall thickness	50 × 3.2 mm	
75 mm diameter/1.9-2.6 wall thickness	50 × 4.2 mm	-/180/180 C/U, C/C, U/C
90 mm diameter/2.0-2.9 wall thickness	50 × 5.0 mm	
110 mm diameter/2.0-3.4 wall thickness	50 × 6.0 mm	
Diameter 125 mm, wall thickness 3.9 mm	60 × 9.0 mm	-/120/120 U/C, C/C
Diameter 160 mm, wall thickness 4.9 mm	60 × 15 mm	-/120/120 C/U, U/U, U/C
Rehau Raupiano Plus PP-DD		
40 mm diameter/1.8 wall thickness	50 × 3.0 mm	-/240/240 U/U
50 mm diameter/1.8 wall thickness	50 × 3.2 mm	
75 mm diameter/1.8-2.2 mm wall thickness	50 × 4.2 mm	-/120/120 C/U
90 mm diameter/1.8-2.4 mm wall thickness	50 × 5.0 mm	
110 mm diameter/1.8-2.7mm wall thickness	50 × 6.0 mm	
Diameter 125 mm, wall thickness 3.1 mm	60 × 9.0 mm	-/180/180 C/U
Diameter 160 mm, wall thickness 3.9 mm	60 × 15.0 mm	-/240/- C/U -/240/240 U/C
BluePower Multilayer pipe – TR02-PP		
32-40 mm diameter/1.8 mm wall thickness	50 × 3.0 mm	-/180/180 U/U
50 mm diameter/1.8 mm wall thickness	50 × 3.2 mm	
75 mm diameter/1.8-3.4 mm wall thickness	50 × 4.2 mm	-/180/180 C/U
90 mm diameter/1.8-3.4 mm wall thickness	50 × 5.0 mm	
110 mm diameter/1.8-3.4 mm wall thickness	50 × 6.0 mm	
125 mm diameter/3.4-4.9 mm wall thickness	60 × 9.0 mm	
160 mm diameter/3.4-4.9 mm wall thickness	60 × 15.0 mm	-/240/240 C/U
Uponor Decibel		
50 mm diameter/ 2.0 mm wall thickness	50 × 3.0 mm	-/180/180 U/U
75 mm diameter/ 2.6 mm wall thickness	50 × 4.2 mm	-/120/120 C/U
110 mm diameter/ 3.8 mm wall thickness	50 × 6.0 mm	

6.7.2 Penetration seals, surface mounted in concrete floors

Penetration seal: Combustible pipes fitted with Protecta FR Collar, to the soffit of the floor.

Construction details:

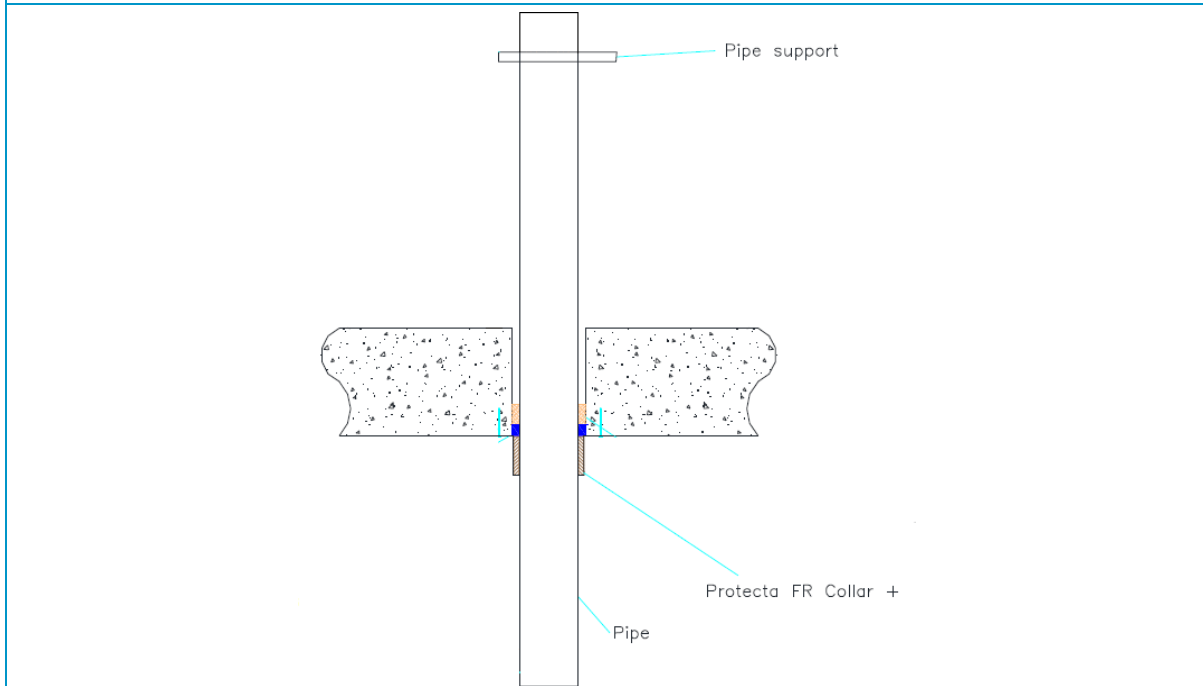

Table 70 PVC-U pipes (diameter 32 – 110 mm) protected with Protecta FR Collar on the exposed side

Services	Collar inlay	FRL
PVC-U pipe		
Diameter 32 mm, wall thickness 2.0-3.7 mm*	50 × 3.0 mm	-/120/120 C/C -/60/60 C/U
Diameter 40 mm, wall thickness 2.0-3.7 mm*		
Diameter 50 mm, wall thickness 2.0-3.7 mm*		
Diameter 55 mm, wall thickness 2.1-3.9 mm*	50 × 3.2 mm	
Diameter 63 mm, wall thickness 2.2-4.3 mm*	50 × 3.6 mm	
Diameter 75 mm, wall thickness 2.3-4.8 mm*	50 × 4.2 mm	
Diameter 82 mm, wall thickness 2.4-5.1 mm*	50 × 4.6 mm	
Diameter 90 mm, wall thickness 2.5-5.4 mm*	50 × 5.0 mm	
Diameter 110 mm, wall thickness 2.7-6.3 mm*	50 × 6.0 mm	
*Typical pipe diameters shown, see below graph for intermediate sizes		

PVC Pipes 32-110 / 50 mm Collar - C/C

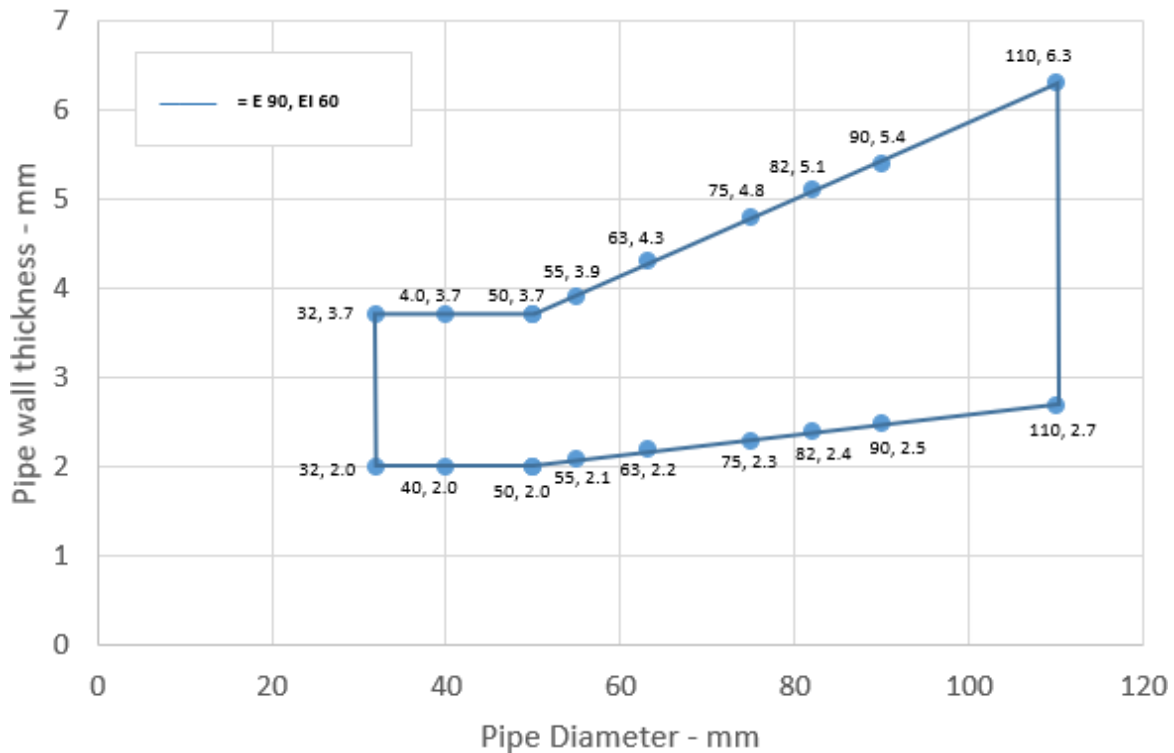

Figure 67 Intermediate pipe wall thicknesses for PVC pipe diameters

Table 71 PVC-U pipes (diameter 200 – 400 mm) protected with Protecta FR Collar on the exposed side

Services	Collar inlay	FRL
PVC-U pipe		
Up to 200 mm diameter / 4.9-11.9 mm wall thickness*	60 × 18 mm	-/120/60 C/C
Up to 250 mm diameter / 6.1-11.9 mm wall thickness*	75 × 24 mm	
Up to 315 mm diameter / 7.7-12.1 mm wall thickness*	75 × 30 mm	
Up to 400 mm diameter / 15.3 mm wall thickness*	100 × 39 mm	
*Typical pipe diameters shown, see below graph for intermediate sizes		

PVC pipes 200-400 / 60-100 mm Collar - C/C

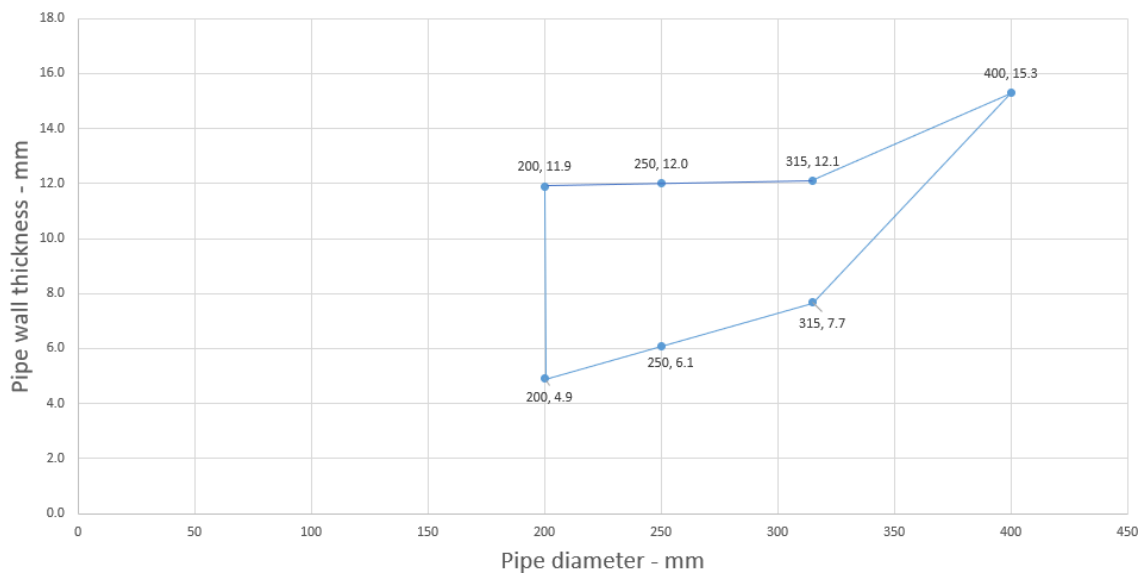

Figure 68 Intermediate pipe wall thicknesses for PVC pipe diameters

Table 72 PE pipes (diameter 200 – 400 mm) protected with Protecta FR Collar on the exposed side

Services	Collar inlay	FRL
PE pipe		
Up to 200 mm diameter / 6.2-18.2 mm wall thickness*	60 × 18 mm	-/240/120 C/C
Up to 250 mm diameter / 11.5-18.4 mm wall thickness*	75 × 24 mm	
Up to 315 mm diameter / 18.7 mm wall thickness*	75 × 30 mm	
Up to 400 mm diameter / 36.3 mm wall thickness*	100 × 39 mm	-/90/90 C/C

*Typical pipe diameters shown, see below graph for intermediate sizes

PE pipes 200-400 / 60-100 mm Collar - C/C

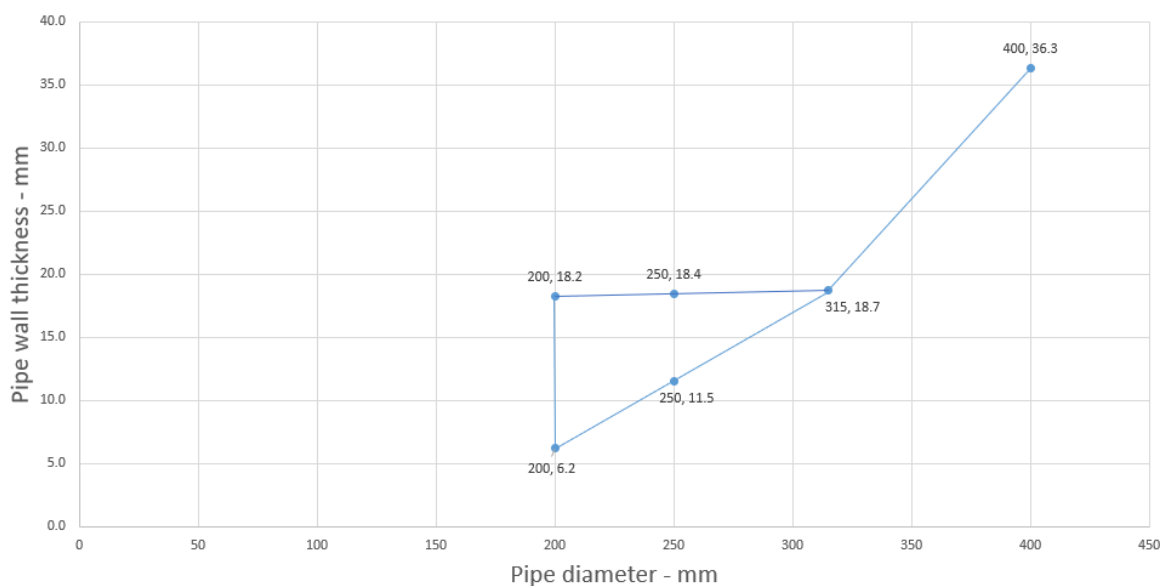

Figure 69 Intermediate pipe wall thicknesses for PE pipe diameters

Table 73 PP pipes (diameter 200 – 400 mm) protected with Protecta FR Collar on the exposed side

Services	Collar inlay	FRL
PP pipe		
Up to 200 mm diameter / 4.9-18.2 mm wall thickness*	60 × 18 mm	-/120/120 C/C
Up to 250 mm diameter / 15.1-22.7 mm wall thickness*	75 × 24 mm	-/60/60 C/C
Up to 315 mm diameter / 28.6 mm wall thickness*	75 × 30 mm	
Up to 400 mm diameter / 9.8-22.7 mm wall thickness*	100 × 39 mm	-/30/30 C/C
*Typical pipe diameters shown, see below graph for intermediate sizes		

PP pipes 200-400 / 60-100 mm Collar - C/C

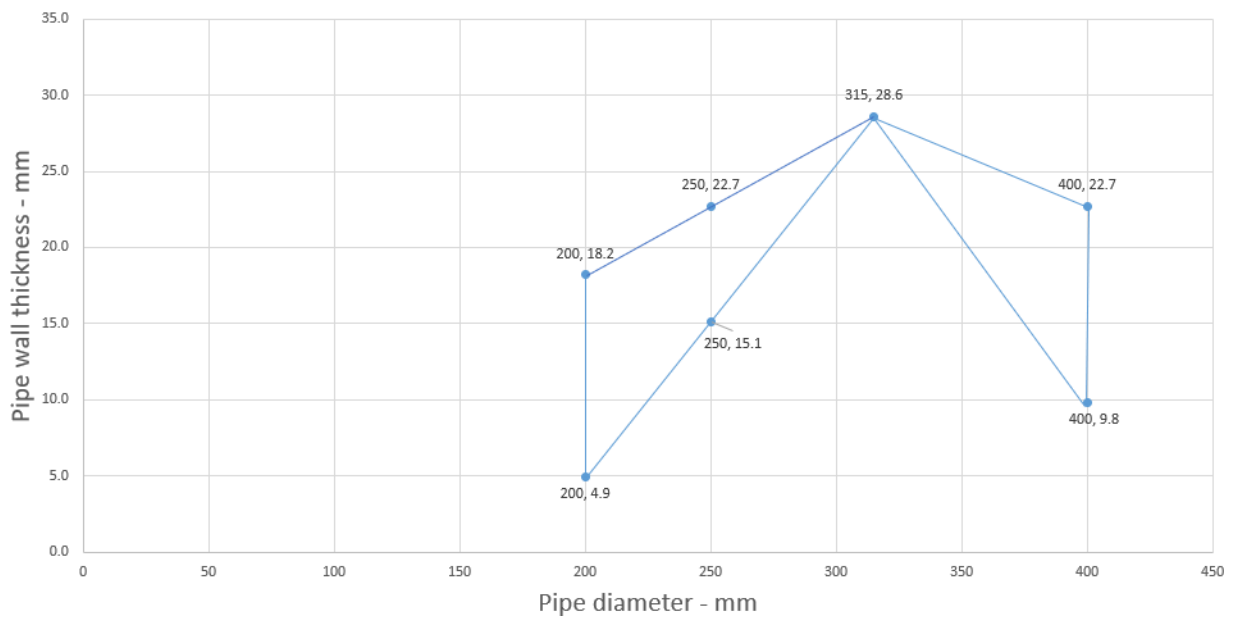

Figure 70 Intermediate pipe wall thicknesses for PP pipe diameters

6.7.3 Penetration seals, surface mounted in concrete floors

Penetration seal: Metallic pipes fitted with Protecta FR Collar, to the soffit of the floor.

Construction details:

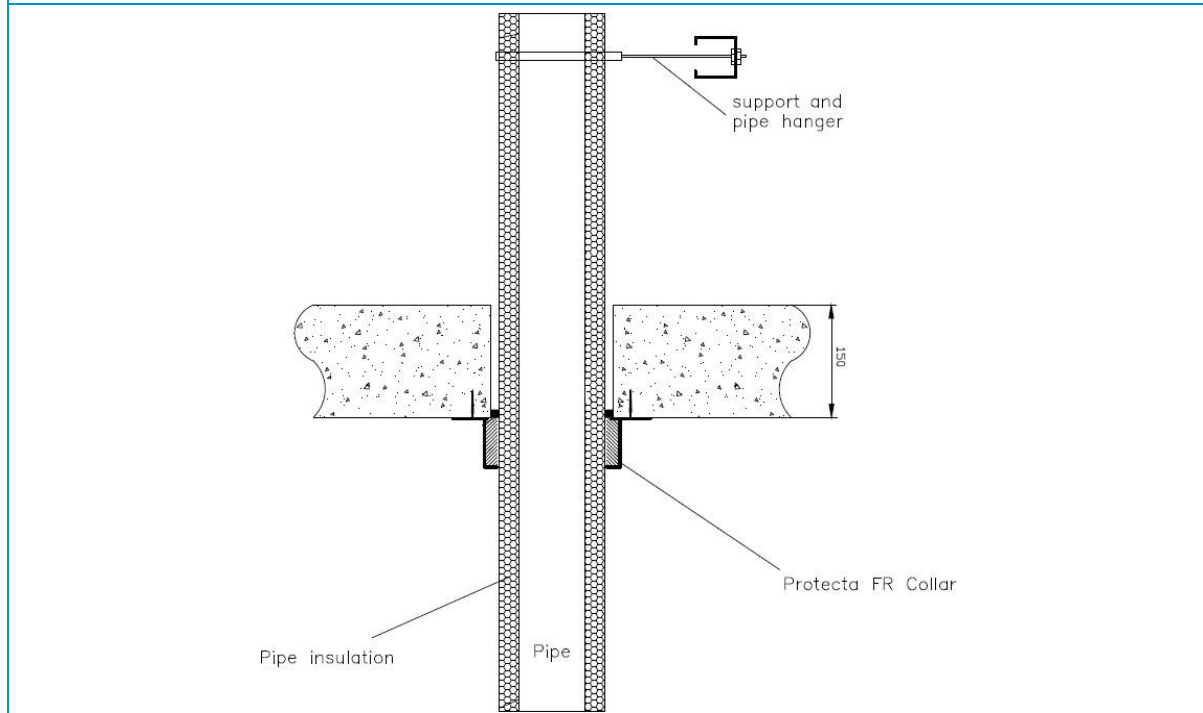

Table 74 Metallic pipes protected with Protecta FR Collar on the exposed side

Services	Insulation	Collar	FRL
Copper pipe or mild steel			
Maximum diameter 42 mm, wall thickness 0.7-14.2 mm*	9 mm thick Elastomeric insulation minimum class D-s3, d0	Up to 63 mm collar at 50 mm height	-/120/120 C/C
Maximum diameter 42 mm, wall thickness 0.7-14.2 mm*	10-50 mm thick Elastomeric insulation minimum class D-s3, d0	Up to 110 mm collar at 50 mm height, 125-160 mm at 60 mm height	-/60/60 C/C
Maximum diameter 54 mm, wall thickness 0.7-14.2 mm*	19 mm thick Elastomeric insulation minimum class B-s3, d0	Up to 110 mm collar at 50 mm height	-/120/60 C/C
Alupex pipe			
Maximum diameter 75 mm, wall thickness 2.25-4.6 mm	9 mm thick Elastomeric insulation minimum class D-s3, d0	Up to 110 mm collar at 50 mm height	-/120/120 C/C
	10-50 mm thick Elastomeric insulation minimum class B-s3, d0	Up to 110 mm collar at 50 mm height, 125-200 mm at 60 mm height	-/120/90 C/C
PE pipe			
Maximum diameter 160 mm, wall thickness 3.0-9.5 mm	9 mm thick Elastomeric insulation minimum class BL-s3, d0	Up to 110 mm collar at 50 mm height, 125-200 mm at 60 mm height	-/180/180 C/C

Services	Insulation	Collar	FRL
	10-50 mm thick Elastomeric insulation minimum class B-s3, d0	Up to 110 mm collar at 50 mm height, 125-200 mm at 60 mm height, 250-315 mm at 75 mm height	-/120/120 C/C
PP pipe			
Maximum diameter 160 mm, wall thickness 1.8-9.1 mm	9 mm thick Elastomeric insulation minimum class BL-s3,d0	Up to 110 mm collar at 50 mm height, 125-200 mm at 60 mm height	-/180/120 C/C
	10-50 mm thick Elastomeric insulation minimum class B-s3,d0	Up to 110 mm collar at 50 mm height, 125-200 mm at 60 mm height, 250-315 mm at 75 mm height	-/60/60 C/C
*Typical pipe diameters shown, see below graph for intermediate sizes			

Copper or Steel Pipes 12-54 / 9-50 mm Elastomeric Insulation - C/C

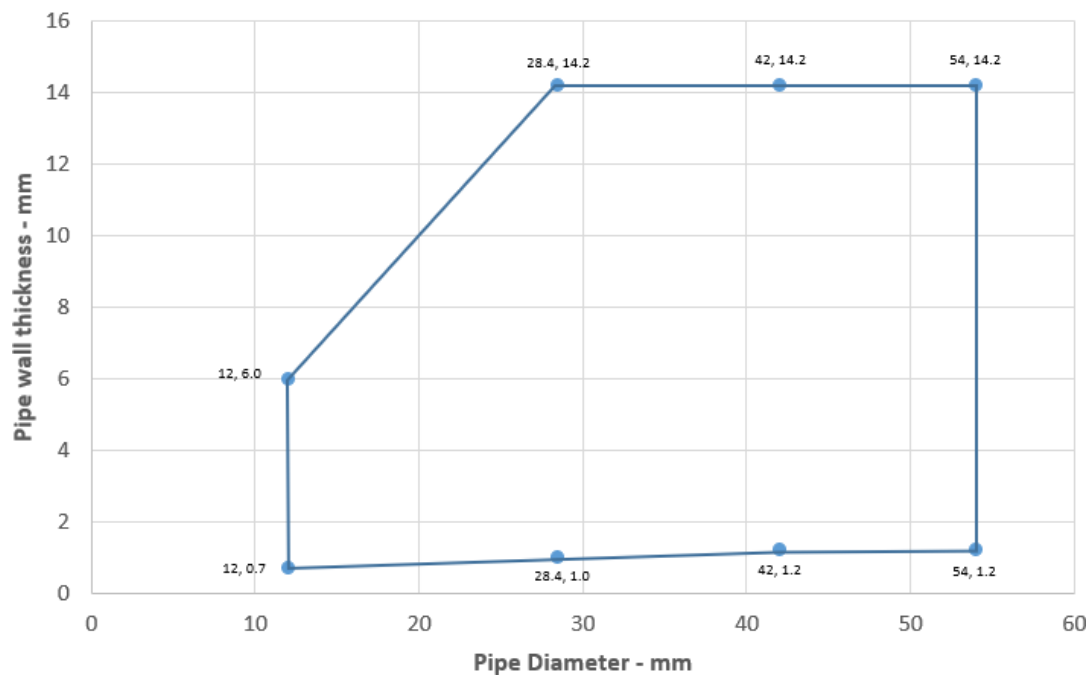

Figure 71 Intermediate pipe wall thicknesses for copper or steel pipe diameters

Alupex Pipes with Elastomeric Pipe Insulation - C/C

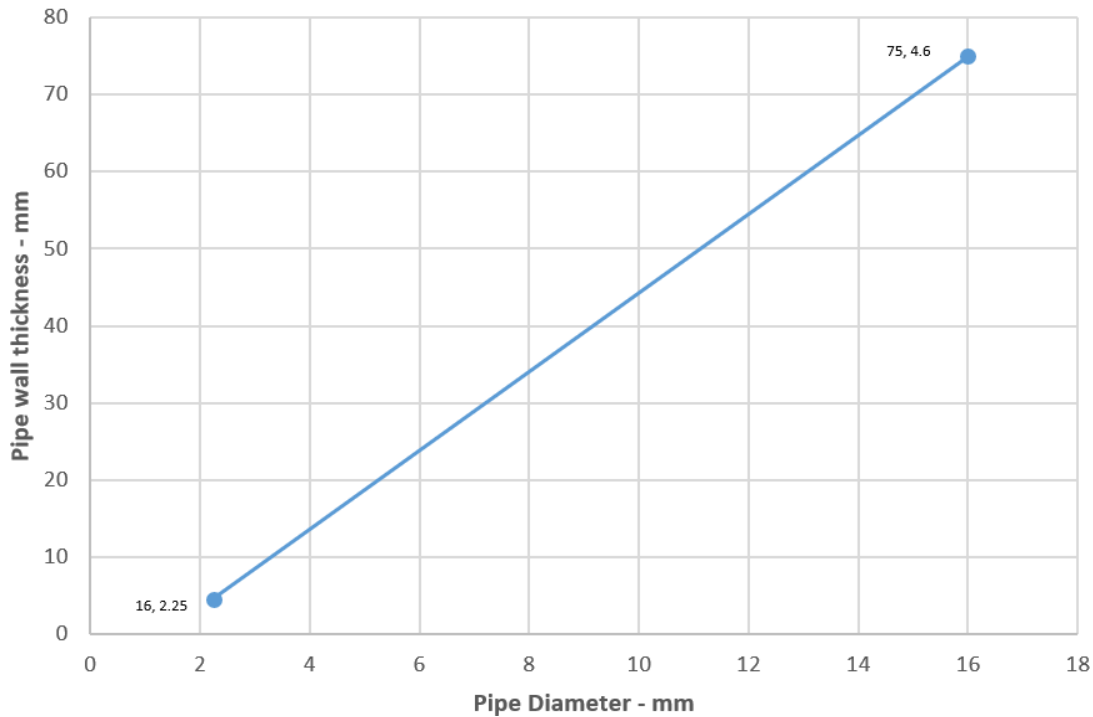

Figure 72 Intermediate pipe wall thicknesses for Alupex pipe diameters

PE Pipes with Elastomeric Pipe Insulation - C/C

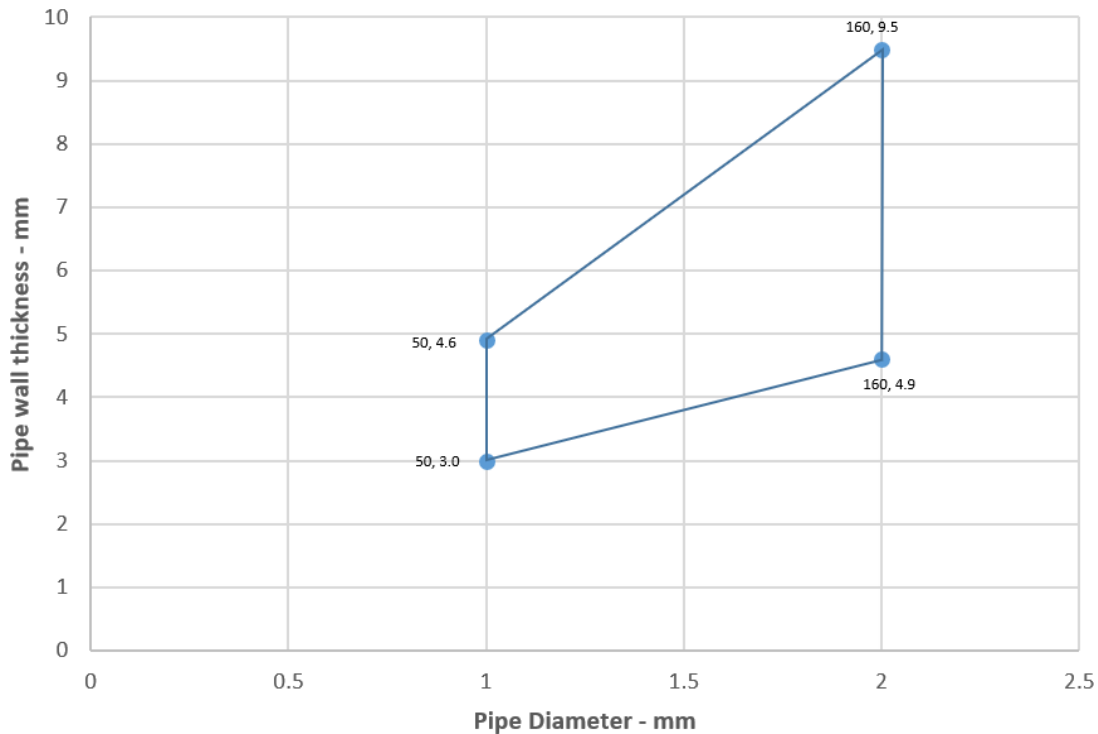

Figure 73 Intermediate pipe wall thicknesses for PE pipe diameters

PP Pipes with Elastomeric Pipe Insulation - C/C

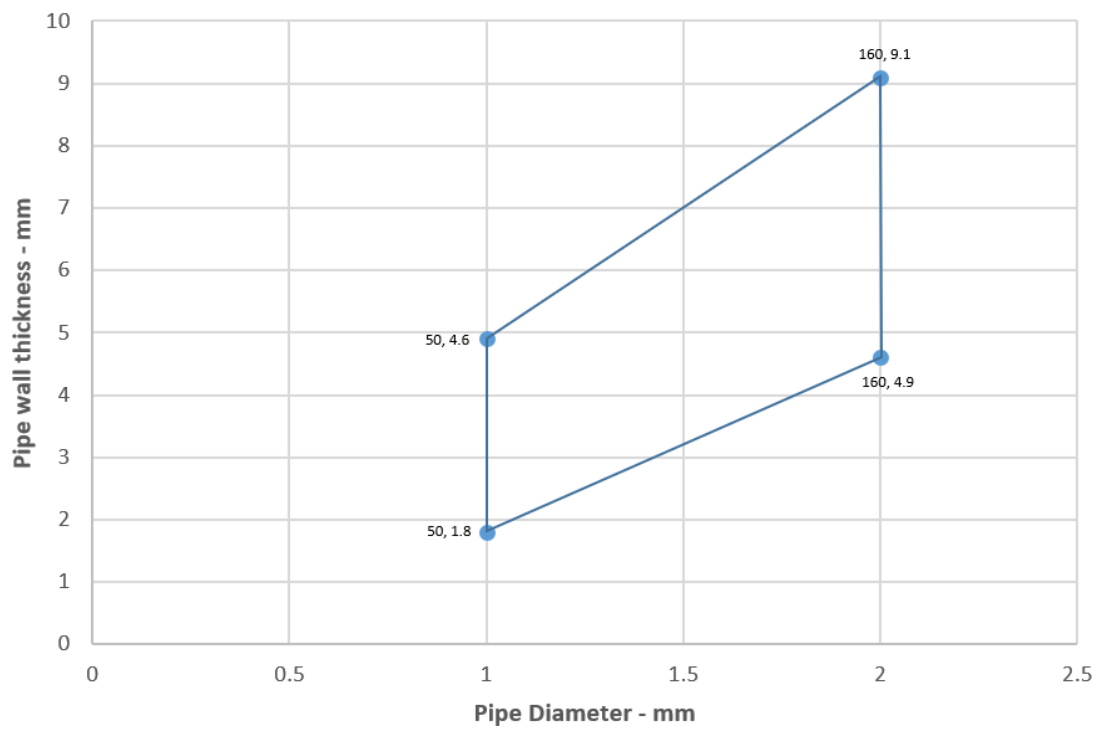

Figure 74 Intermediate pipe wall thicknesses for PP pipe diameters

6.7.4 Penetration seals, surface mounted in concrete floors

Penetration seal: Cables (in bundles up to Ø 100 mm) fitted with Protecta FR Collar, to the soffit of the floor.

Construction details:

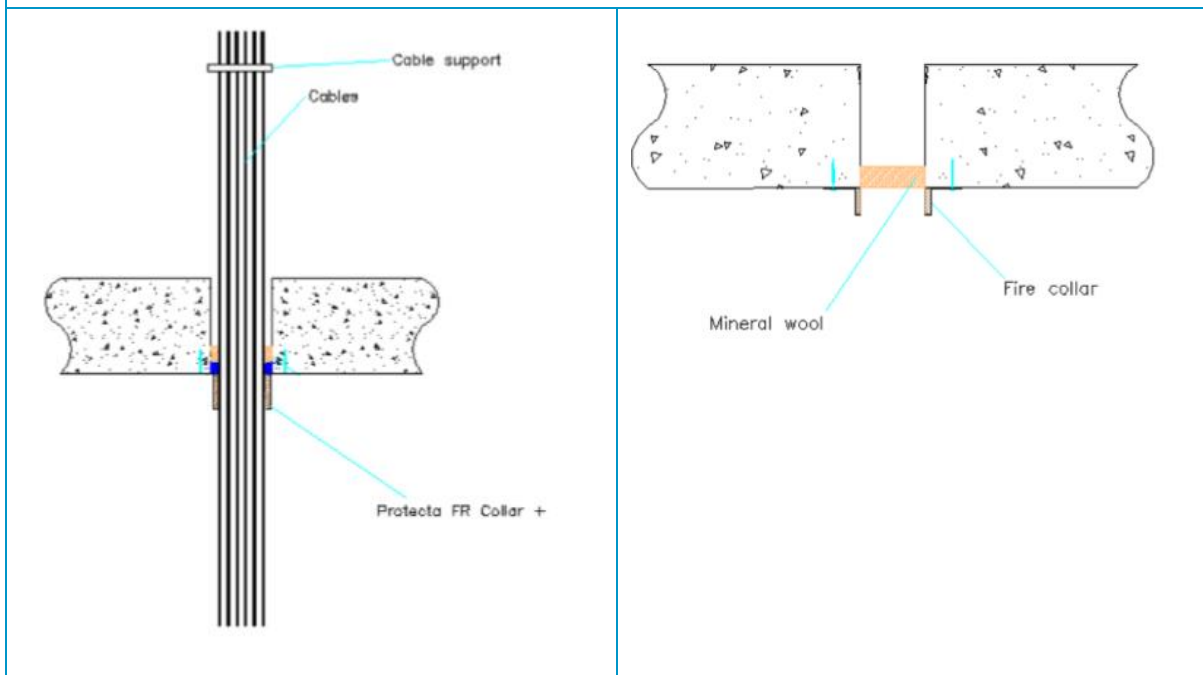

Table 75 Cables penetrating a 150mm thick concrete slab and protected with Protecta FR collar and blank seals protected with Protecta FR collar

Services	Collar inlay	FRL
None (blank)	Ø 55 × 30 × 3.2 mm	-/240/60
None (blank)	Ø 160 × 60 × 15.0 mm	-/120/120
Cables up to Ø 21 mm, in bundles up to Ø 55 mm	Ø 55 × 30 × 3.2 mm	-/120/120
Cables up to Ø 21 mm, in bundles up to Ø 100 mm	Ø 110 × 50 × 6.0 mm	-/90/90
Cables up to Ø 21 mm, in bundles up to Ø 160 mm	Ø 160 × 60 × 15.0 mm	-/180/180
PVC pipes up to Ø 32 mm, wall thickness 1.0-2.4 mm with or without cables up to 21 mm Ø, in partial or fully filled pipe bundles up to Ø 160 mm *	Up to 110 mm collar at 50 mm height, 125-160 mm at 60 mm height	-/90/90 C/U
PE pipes up to Ø 32 mm, wall thickness 2.0-3.0 mm with or without cables up to Ø 21 mm, in partial or fully filled pipe bundles up to Ø 160 mm *		
PEX pipe-in-pipe system		
Diameter up to 25 mm pipes, wall thicknesses 0.6 mm outer and 2.5 mm inner pipe, in bundle up to 50 mm	50 mm collar at 50 mm height	-/90/90 C/C
* PVC, PE and PP pipes can be mixed in the same bundle		

6.7.5 Penetration seals, surface mounted in concrete floors

Penetration seal: Combustible pipes fitted with Protecta FR Collar, to the top face of the floor.

Construction details:

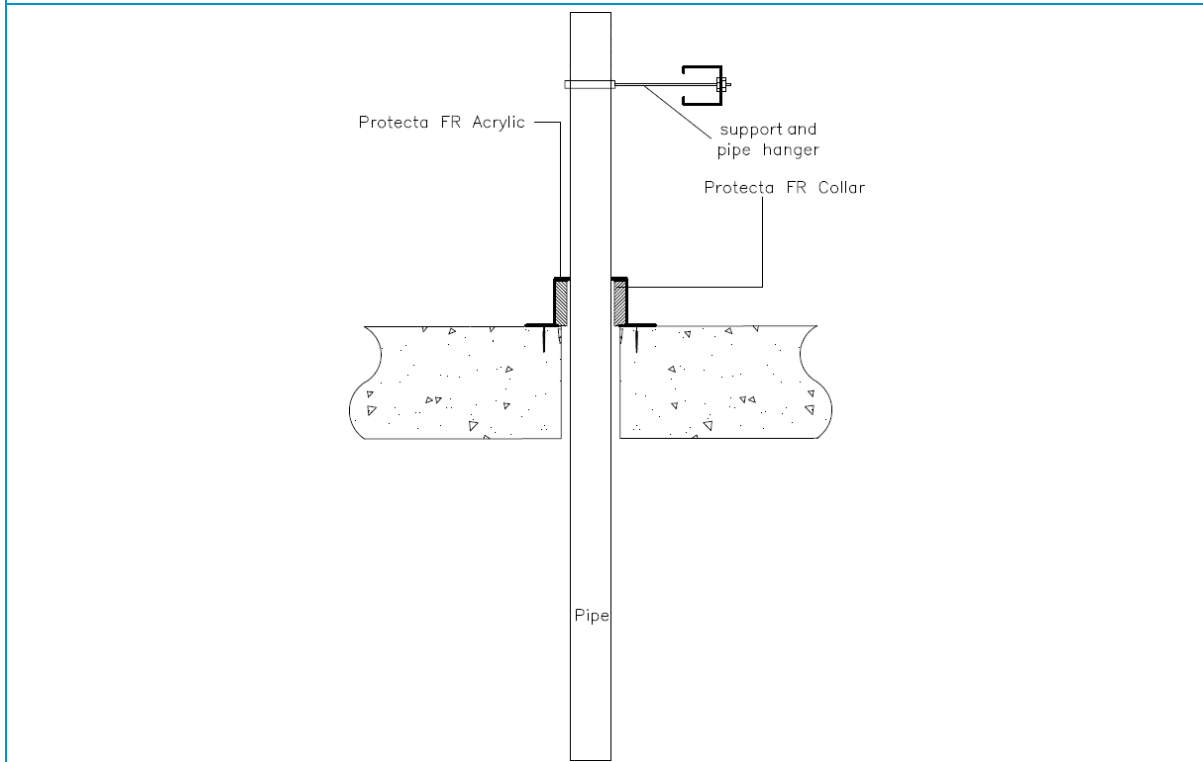

Table 76 PVC-U pipes (diameters 32 – 160 mm) protected with Protecta FR collar on the unexposed side

Services	Collar inlay	FRL
PVC-U pipe		
Diameter 32 mm, wall thickness 1.9-3.7 mm	50 × 3.0 mm	-/240/240 U/C
Diameter 40 mm, wall thickness 1.9-3.7 mm	50 × 3.0 mm	
Diameter 50 mm, wall thickness 1.9-3.7 mm	50 × 3.2 mm	
Diameter 55 mm, wall thickness 2.0-4.0 mm	50 × 3.2 mm	-/120/120 U/C
Diameter 63 mm, wall thickness 2.1-4.4 mm	50 × 3.6 mm	
Diameter 75 mm, wall thickness 2.4-5.0 mm	50 × 4.2 mm	
Diameter 82 mm, wall thickness 2.5-5.3 mm	50 × 4.6 mm	
Diameter 90 mm, wall thickness 2.7-5.7 mm	50 × 5.0 mm	
Diameter 110 mm, wall thickness 3.2-6.6 mm	50 × 6.0 mm	-/240/180 U/C
Diameter 125 mm, wall thickness 5.0-7.5 mm	60 × 8.8 mm	
Diameter 140 mm, wall thickness 6.9-8.3 mm	60 × 11.5 mm	
Diameter 160 mm, wall thickness 9.5 mm	60 × 15 mm	
Diameter 125 mm, wall thickness 4.1-7.5 mm	60 × 8.8 mm	-/180/90 U/C
Diameter 140 mm, wall thickness 5.0-8.3 mm	60 × 11.5 mm	
Diameter 160 mm, wall thickness 6.2-9.5 mm	60 × 15 mm	

PVC pipes 50-160 / 50-60 mm Collar - U/C

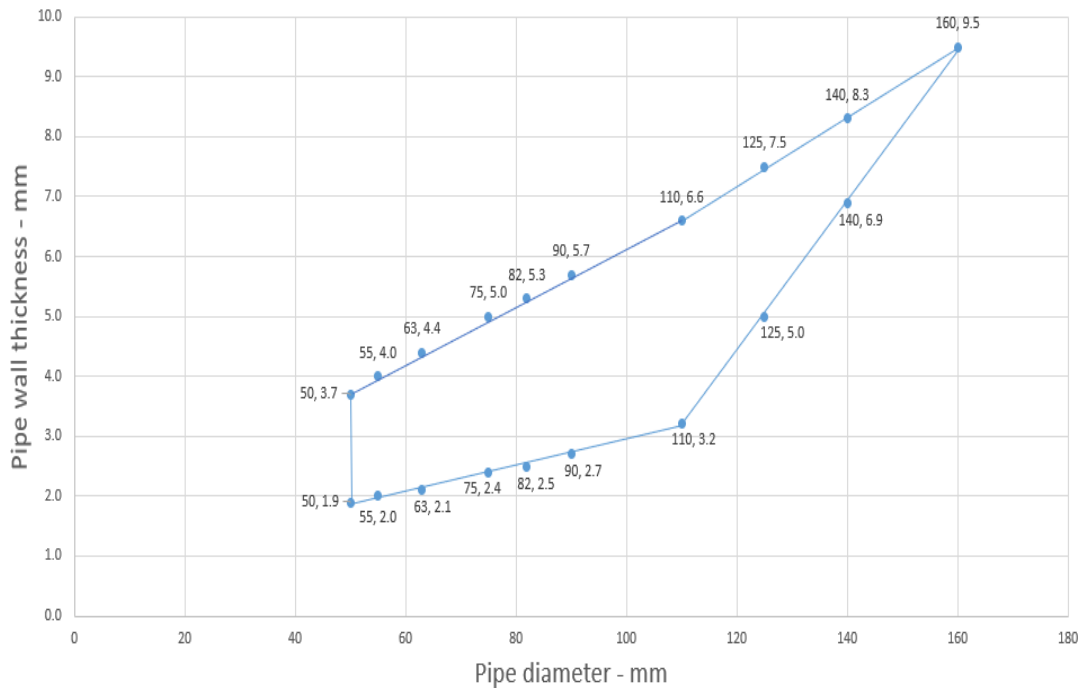

Figure 75 Intermediate pipe wall thicknesses for PVC pipe diameters

PVC Pipes 110-160 - U/C

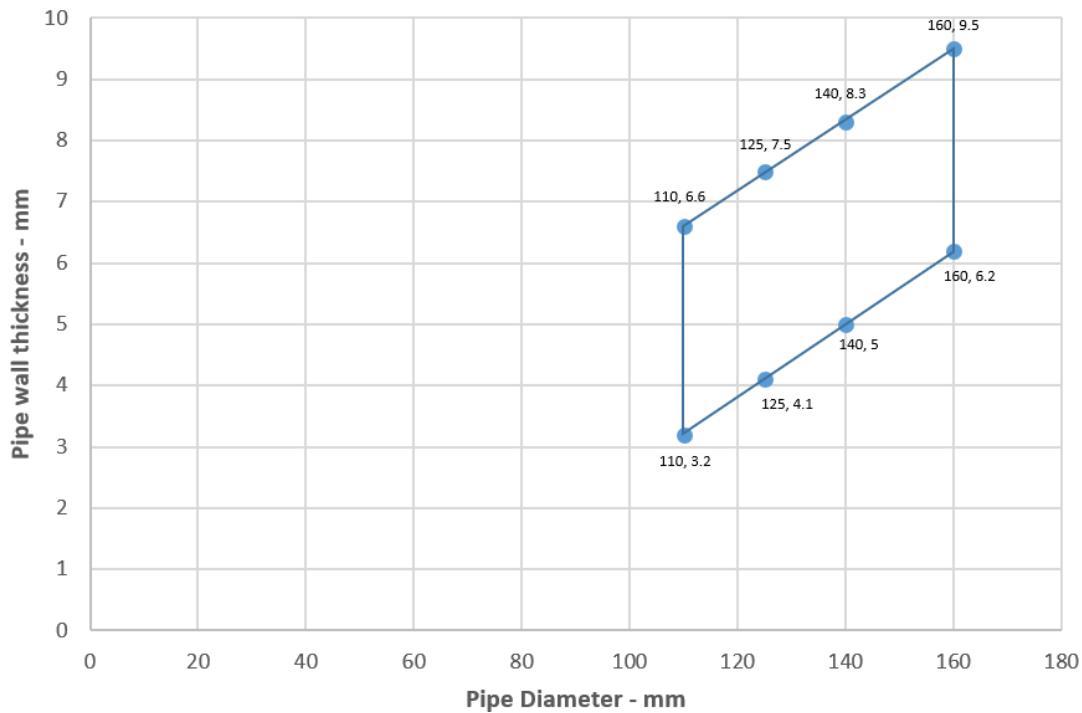

Figure 76 Intermediate pipe wall thicknesses for PVC pipe diameters

Table 77 PE pipes (diameters 32 – 160 mm) protected with Protecta FR collar on the unexposed side

Services	Collar inlay	FRL
PE pipe		
Diameter 32 mm, wall thickness 3.0-4.6 mm	50 × 3.0 mm	-/240/240 U/C
Diameter 40 mm, wall thickness 3.0-4.6 mm	50 × 3.0 mm	
Diameter 50 mm, wall thickness 3.0-4.6 mm	50 × 3.2 mm	
Diameter 55 mm, wall thickness 3.0-5.1 mm	50 × 3.2 mm	-/240/60 U/C
Diameter 63 mm, wall thickness 3.0-5.8 mm	50 × 3.6 mm	
Diameter 75 mm, wall thickness 3.1-6.9 mm	50 × 4.2 mm	
Diameter 82 mm, wall thickness 3.2-7.5 mm	50 × 4.6 mm	
Diameter 90 mm, wall thickness 3.2-8.2 mm	50 × 5.0 mm	
Diameter 110 mm, wall thickness 3.4-10.0 mm	50 × 6.0 mm	
Diameter 125 mm, wall thickness 3.9-9.8 mm	60 × 8.8 mm	-/60/60 U/C
Diameter 140 mm, wall thickness 4.3-9.7 mm	60 × 11.5 mm	
Diameter 160 mm, wall thickness 4.9-9.5 mm	60 × 15 mm	

PE Pipes 50-110 / 50 mm collar - U/C

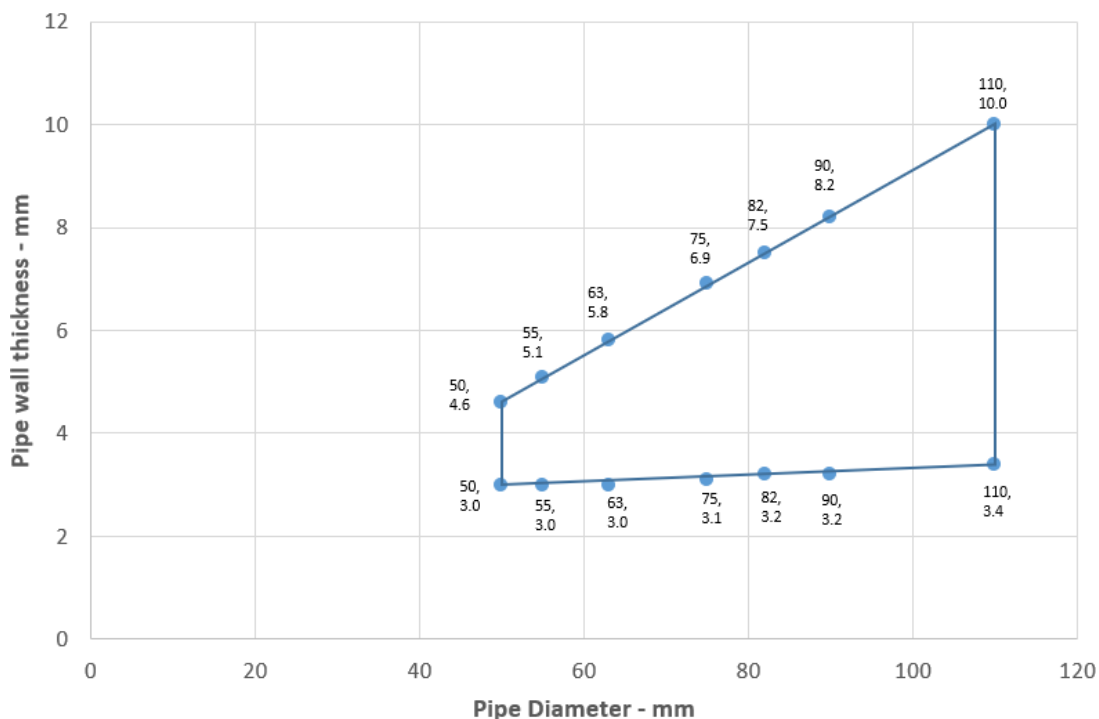

Figure 77 Intermediate pipe wall thicknesses for PE pipe diameters

PE Pipes 110-160 - U/C

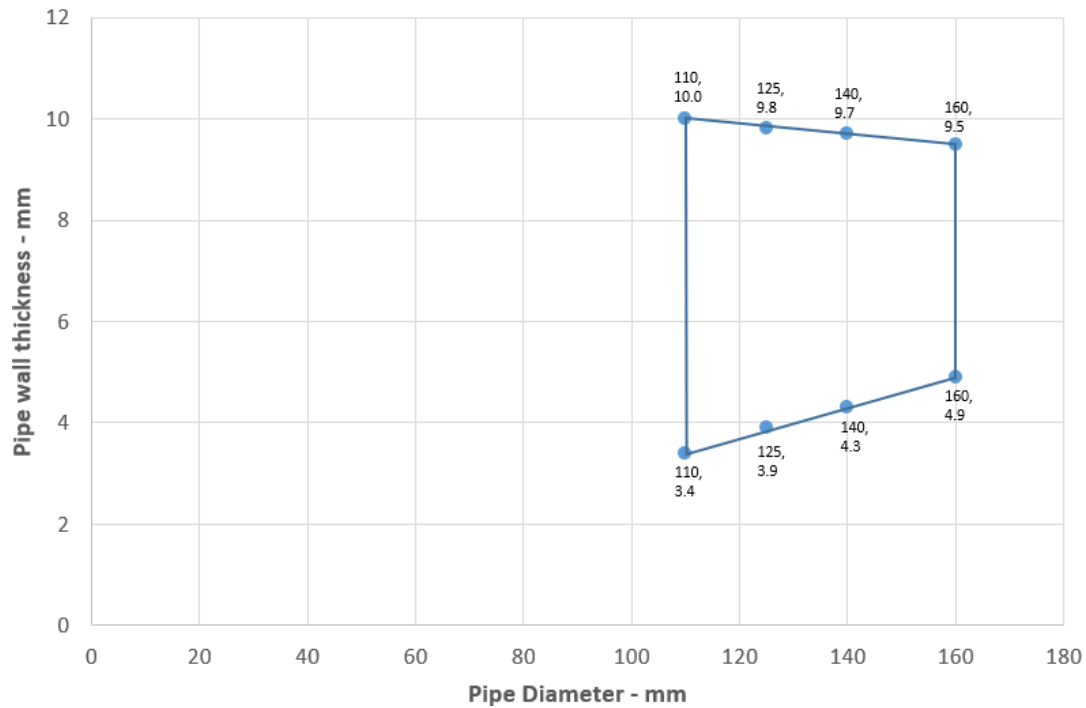

Figure 78 Intermediate pipe wall thicknesses for PE pipe diameters

Table 78 PP pipes (diameters 32 – 160 mm) protected with Protecta FR collar on the unexposed side

Services	Collar inlay	FRL
PP pipe		
Diameter 32 mm, wall thickness 2.9-4.6 mm	50 × 3.0 mm	-/240/180 U/C
Diameter 40 mm, wall thickness 2.9-4.6 mm	50 × 3.0 mm	
Diameter 50 mm, wall thickness 2.9-4.6 mm	50 × 3.2 mm	
Diameter 55 mm, wall thickness 3.5-5.1 mm	50 × 3.2 mm	-/180/90 U/C
Diameter 63 mm, wall thickness 4.4-5.8 mm	50 × 3.6 mm	
Diameter 75 mm, wall thickness 5.8-6.9 mm	50 × 4.2 mm	
Diameter 82 mm, wall thickness 6.6-7.5 mm	50 × 4.6 mm	
Diameter 90 mm, wall thickness 7.5-8.2 mm	50 × 5.0 mm	
Diameter 110 mm, wall thickness 10.0 mm	50 × 6.0 mm	-/240/60 U/C
Diameter 125 mm, wall thickness 11.3 mm	60 × 8.8 mm	
Diameter 140 mm, wall thickness 12.7 mm	60 × 11.5 mm	
Diameter 160 mm, wall thickness 14.6 mm	60 × 15 mm	

PP pipes 50-160 / 50-60 mm Collar - U/C

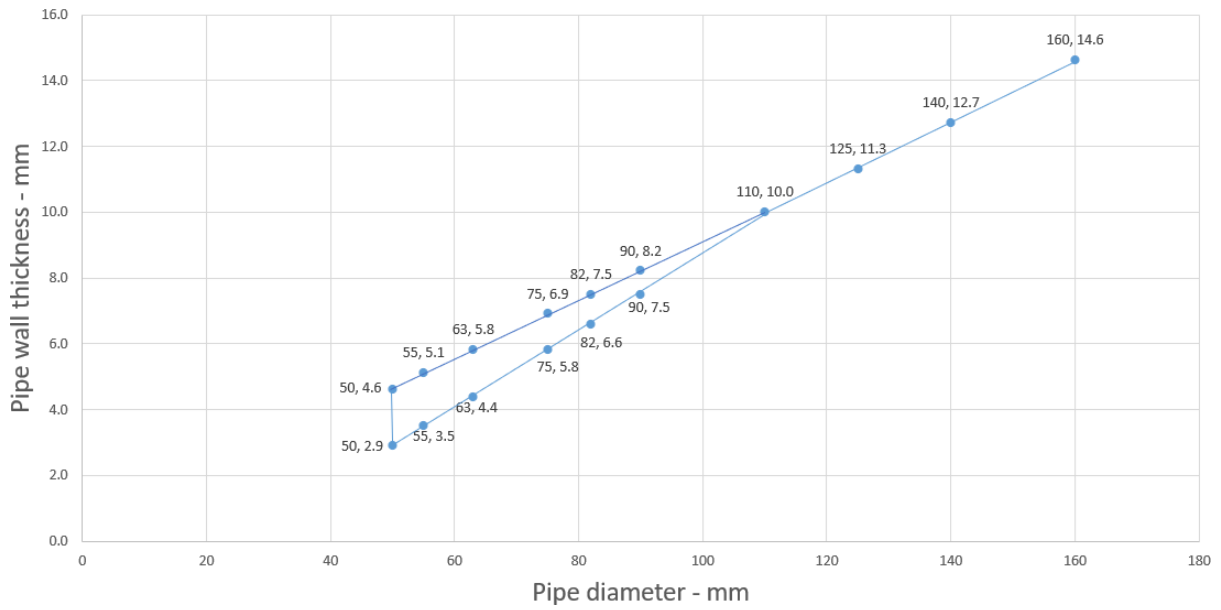

Figure 79 Intermediate pipe wall thicknesses for PP pipe diameters

7. Assessment of specific variations

7.1 Description of variation

The tested systems are to be varied as per the variations described in section 4.3.

7.2 Methodology

The method of assessment used is summarised in Table 79.

Table 79 Method of assessment

Assessment method	
Level of complexity	Complex assessment
Type of assessment	Qualitative / Comparative

7.3 Assessment

7.3.1 Assessment of plastic pipes protected with Protecta FR Collar installed in flexible wall system if tested in accordance with AS 1530.4:2014

Proposed construction

- Flexible wall systems must have a minimum thickness of 75 mm and consist of steel or timber studs lined on both faces with 1 layer of minimum 12.5 mm thick fire rated plasterboard. The achieved FRLs are applicable to a flexible wall system with optional insulation and the aperture can optionally be lined.
- For timber framed walls, it is required that no part of the penetration seal is closer than 100 mm to a stud, the cavity is closed between the penetration seal and the stud, and minimum 100 mm of insulation is provided with the cavity between the penetration seal and the stud.
- Rigid walls must have a minimum thickness of 75 mm or as otherwise specified and consist of concrete, aerated concrete, or masonry with a minimum density of 650 kg/m³.

Discussion

With reference to the tests in Appendix B, some of the tested constructions the tested constructions consisted of a flexible wall system that comprise a 50 mm steel stud cladded with one layer of 12.5 mm on each side. The cavity between the plasterboard and steel studs was friction fitted with 50 mm thick mineral wool which was cut back 100 mm from all around the aperture.

The Protecta FR collars were fitted on both faces of the separating element and fixed to the separating element by 4 No. M5 × 72 mm hollow wall anchor fixings.

As the insulation was cut all around the aperture, the FRL achieved can be applicable to wall systems with insulation and without insulation. Moreover, as the aperture was not lined in the referenced tests, the FRLs will also be applicable to apertures with or without lining.

In flexible walls, it is considered that the gaps between the pipe and the construction must be sealed by a bead of Protecta FR Acrylic sealant. A bead of Protecta FR Acrylic must be sufficient for any gaps that are less than 8 mm. Any bigger gaps must be sealed with 25 mm deep FR Acrylic sealant.

Similarly, in rigid walls, gaps that are less than 8 mm must be sealed by a bead of FR Acrylic sealant. However, in larger gaps, 20 mm deep FR Acrylic sealant must be used backed with 20 mm stone wool.

Based on this discussion, it is considered that the pipe and the cable services summarised in section 6 will likely achieve the FRLs given in section 6 if tested in accordance with AS 1530.4:2014 and AS 4072.1:2005.

7.3.2 Assessment of plastic pipes protected with Protecta FR Collar installed in rigid floor and composite floor systems if tested in accordance with AS 1530.4:2014

Proposed construction

The proposed construction must be as tested subject to the following variations:

- Rigid floors must have a minimum thickness of 150 mm and comprise aerated concrete or concrete with a minimum density of 650 kg/m³. Floors are required to be otherwise tested to achieve FRL of 240/240/240 or -/240/240.
- Applicability of FRLs to thinner concrete slab of minimum thickness 100 mm.

Discussion

It is considered that the proposed construction will be similar to the construction referenced in tests given in Appendix B, which consisted of various plastic pipes, metallic and composite pipes and cable services installed within a reinforced AAC lintel floor slab on top of a 1.5 m × 1.5 m furnace aperture.

The referenced tests covered the installation of the Protecta FR Collar installed at the exposed side in some tests and on the unexposed in others with both fixed to the concrete slab with 4 No. 60 mm long masonry screws.

For collars installed on the exposed side, the gaps between the pipe and the construction that are below 10 mm must have a 20 mm deep stonewool to seal the opening, and for gaps of 10 mm and above the seal must be plugged with 10 mm deep FR Acrylic on 40 mm deep backing of stonewool. Where collars are installed on the unexposed side, gaps between the pipe and the top side of the collar must have a bead of Protecta FR Acrylic to cover the opening.

Applicability of FRLs given to 150 mm thick floors to thinner concrete slabs of minimum thickness 100 mm is permissible. Insulation performance of the system will be governed by the concrete slab thickness as stated in AS/NZS 3600:2018. The overall FRL of the system will be governed by the FRL extracted from AS/NZS 3600:2018 as shown below:

Table 80 Maximum fire resistance for given slab thicknesses

Effective Slab Thickness	Maximum Fire Resistance
100 mm	90 minutes
120 mm	120 minutes
150 mm	180 minutes
175 mm	240 minutes

Where single sided top face seals are described in section 6.7.5, these can also be used in composite floors if the thickness of the concrete at the thinnest location is the same or greater than the required depth. Composite floors with equivalent aperture sizes are required to be otherwise tested or assessed by others to achieve a nominated FRL. In cases where the FRL of the floor is less than the penetration protecting the overall system, the FRL will be derated accordingly to match with the FRL of the composite floor.

7.3.3 Applicability in both walls and floors

- It was confirmed that the tested Polyethylene pipes were PE100 which as confirmed by report sponsor and pipe manufacturer is similar to HDPE pipes. Therefore, the FRLs shown for PE pipes in section 6 are applicable to HDPE, ABS and SAN+PVC pipes.
- Test results for cables remain valid if the diameter of a single cable is reduced and/or number of cables in a bunch is reduced provided that overall diameter of the bunch of any individual cable is not greater than tested.

The test results obtained with standard configuration covers all types of insulated cables with copper or aluminium conductors, fibre optic cables and bundled communication cables, except hollow cables.

- Results obtained from tests where the supports pass through the seal are applicable to those situations where the support is not continued but not vice versa
- The test results obtained using standard configuration for cable penetration systems are valid for:
 - All type of steel cable trays and ladders
 - Any penetration size equal or smaller than that tested, provided the total amount of cross sections of the cables (core and insulation) does not exceed 60% of the penetration.
- Support of services in walls and floors must be maintained as per AS 1530.4:2014 and AS 4072.1:2005 requirements.
- Some of the Protecta FR Collars were tested oversized, i.e. the internal diameter of the collar is larger than the pipe diameter.

Oversize collars can be used as a method of fire protection in both walls and floors for any type of services as assessed in section 6 including both pipes and cables where the requirement for oversize collars arise due to angling of services or oversized apertures. However, when used with over-sized collars, the fire resistance performance of any 180 minutes or 240 minutes systems must be reduced to maximum 120 minutes in integrity and insulation.

The minimum angle tested is 45° as shown in the example in clause 6.5.2 and so this allows the use of over-sized collars for pipes at angles from 90° to 45°. The maximum collar size tested is 160 mm and is the maximum size assessed in this report. The maximum average annular space to be used with over-sized collars is 55 mm.

7.3.4 Applicability of results to uninsulated pipes

It is proposed that the integrity rating achieved for insulated pipes is applied to uninsulated pipes.

As per AS 1530.4:2014, a specimen must be deemed to have failed the integrity criterion in when any of the following occur:

- Sustained flaming for 10 seconds
- A gap form that allows the passage of hot gases to the unexposed face and ignite the cotton pad when applied for up to 30 seconds
- A gap forms that allows the penetration of a 25 mm gap gauge anywhere on the specimen
- A gap forms that allows a 6 mm × 150 mm gap gauge to penetrate the specimen (anywhere on the specimen).

Upon closer inspection of the tested specimens, it was observed that the above systems were able to maintain integrity performance for the duration of the test with no significant observations on cracks or gaps forming around the penetration on the unexposed side that could have promoted an integrity failure. Moreover, it is acknowledged that the insulation provided on the metallic and composite pipes is for insulation rating purposes only as it was interrupted and did not continue through the penetration.

Therefore, it is established that the insulation around the pipes has no bearing on the fire integrity rating of the system and assuming that the insulation rating is zero, removing the insulation on the pipe systems will not cause any detrimental effect to the integrity rating of the pipe system. This variation can therefore be positively assessed.

8. Validity

Warringtonfire Australia does not endorse the tested or assessed product in any way. The conclusions of this assessment may be used to directly assess fire hazard, but it should be recognised that a single test method will not provide a full assessment of fire hazard under all conditions.

Due to the nature of fire testing and the consequent difficulty in quantifying the uncertainty of measurement, it is not possible to provide a stated degree of accuracy. The inherent variability in test procedures, materials and methods of construction, and installation may lead to variations in performance between elements of similar construction.

This assessment is based on information and experience available at the time of preparation. The published procedures for the conduct of tests and the assessment of test results are subject to constant review and improvement. It is therefore recommended that this report be reviewed on, or before, the stated expiry date.

This assessment represents our opinion about the performance likely to be demonstrated on a test in accordance with AS 1530.4:2014 and assessed in accordance with AS 4072.1:2005, based on the evidence referred to in this report.

This assessment is provided to Polyseam Ltd for their own specific purposes. Building certifiers and other third parties are responsible for deciding if they accept this assessment in a particular context.

Appendix A Drawings and additional information

Table 81 Details of figures

Figures	Source
All drawings of construction details and graphical representation of intermediate service diameters and wall thicknesses as provided in section 6.	Extracted from the European Technical Assessment ETA-21/0070 of 2021/01/01 provided by Polyseam Ltd.

Appendix B Summary of supporting test data

B.1 Test report – WF 423530

Table 82 Information about test report WF 423530

Item	Information about test report
Report sponsor	Polyseam Ltd, St Andrews Road, Huddersfield, West Yorkshire, HD1, 6SB, UK.
Test laboratory	Warringtonfire, Chiltern House, Stocking Lane, High Wycombe, HP14, 4ND, UK.
Test date	The fire resistance test was completed on 29 January 2020.
Test standards	The test was done in accordance with BS EN 1363-1:2012 and BS EN 1366-3:2009.
Variation to test standards	None
General description of tested specimen	<p>The supporting construction comprised of a 3000 mm wide × 3000 mm high steel stud / plasterboard clad partition. The partition framing consisted of 50 mm wide C-section studs at 600 mm centres with 50 mm thick 33 kg/m³ density mineral wool insulation friction fitted between the studs, and clad on both faces with 1 layer of 12.5 mm thick Type F plasterboard.</p> <p>The services referenced in this assessment report are referenced in Table 83. All pipes and cables measured 1200 mm long with a minimum of 500 mm protruding from the exposed face.</p>
Instrumentation	The test report states that the instrumentation was in accordance with BS EN 1363-1:2012 and BS EN 1366-3:2009.

The test specimen achieved the following results – see Table 83.

Table 83 Results summary for this test report

Specimen	Aperture	Seal description	Service insulation	FRL
C – PVC pipe with an outer diameter of Ø 50 mm and a pipe wall thickness of 2.4 mm	Ø 54 mm	<p>Pipe capping: U/U</p> <p>Protecta FR Collar 50 mm fitted both faces (size 3 mm thick × 30 mm deep).</p> <p>Protecta FR Acrylic fitted on both faces (size 2 mm wide × 2 mm deep).</p>	None.	-/60/30
D – PVC pipe with an outer diameter of Ø 110 mm and a pipe wall thickness of 2.7 mm	Ø 114 mm	<p>Pipe capping: U/C</p> <p>Protecta FR Collar 110 mm fitted both faces (size 6 mm thick × 30 mm deep).</p> <p>Protecta FR Acrylic fitted on both faces (size 2 mm wide × 2 mm deep).</p>	None.	-/60/45
E – PVC pipe with an outer diameter of Ø 160 mm and a pipe wall thickness of 3.2 mm	Ø 164 mm	<p>Pipe capping: U/C</p> <p>Protecta FR Collar 160 mm fitted both faces (size 15 mm thick × 60 mm deep).</p> <p>Protecta FR Acrylic fitted on both faces (size 2 mm wide × 2 mm deep).</p>	None.	-/60/60
F – PVC pipe with an outer diameter of Ø 160 mm and a pipe wall thickness of 9.5 mm	Ø 164 mm	<p>Pipe capping: U/C</p> <p>Protecta FR Collar 160 mm fitted both faces (size 15 mm thick × 60 mm deep).</p>	None.	-/60/45

Specimen	Aperture	Seal description	Service insulation	FRL
		Protecta FR Acrylic fitted on both faces (size 2 mm wide × 2 mm deep).		
G – PVC pipe with an outer diameter of Ø 110 mm and a pipe wall thickness of 6.6 mm	Ø 114 mm	Pipe capping: U/C Protecta FR Collar 110 mm fitted both faces (size 6 mm thick × 30 mm deep). Protecta FR Acrylic fitted on both faces (size 2 mm wide × 2 mm deep).	None.	-/60/45
H – PVC pipe with an outer diameter of Ø 50 mm and a pipe wall thickness of 4.6 mm	Ø 54 mm	Pipe capping: U/U Protecta FR Collar 50 mm fitted both faces (size 3 mm thick × 30 mm deep). Protecta FR Acrylic fitted on both faces (size 2 mm wide × 2 mm deep).	None.	-/60/45
J – PP pipe with an outer diameter of Ø 50 mm and a pipe wall thickness of 2.0 mm	Ø 54 mm	Pipe capping: U/U Protecta FR Collar 50 mm fitted both faces (size 3 mm thick × 30 mm deep). Protecta FR Acrylic fitted on both faces (size 2 mm wide × 2 mm deep).	None.	-/60/30
K – PP pipe with an outer diameter of Ø 110 mm and a pipe wall thickness of 3.4 mm	Ø 114 mm	Pipe capping: U/C Protecta FR Collar 110 mm fitted both faces (size 6 mm thick × 30 mm deep). Protecta FR Acrylic fitted on both faces (size 2 mm wide × 2 mm deep).	None.	-/60/45
L – PP pipe with an outer diameter of Ø 160 mm and a pipe wall thickness of 4.9 mm	Ø 164 mm	Pipe capping: U/C Protecta FR Collar 110 mm fitted both faces (size 15 mm thick × 60 mm deep). Protecta FR Acrylic fitted on both faces (size 2 mm wide × 2 mm deep).	None.	-/60/60
M – PP pipe with an outer diameter of Ø 160 mm and a pipe wall thickness of 14.6 mm	Ø 164 mm	Pipe capping: U/C Protecta FR Collar 160 mm fitted both faces (size 15 mm thick × 60 mm deep). Protecta FR Acrylic fitted on both faces (size 2 mm wide × 2 mm deep).	None.	-/60/60
N – PE pipe with an outer diameter of Ø 160 mm and a pipe wall thickness of 6.2 mm	Ø 164 mm	Pipe capping: U/C Protecta FR Collar 160 mm fitted both faces (size 15 mm thick × 60 mm deep). Protecta FR Acrylic fitted on both faces (size 2 mm wide × 2 mm deep).	None.	-/60/45
O – PP pipe with an outer diameter of Ø 110 mm and	Ø 114 mm	Pipe capping: U/C	None.	-/60/45

Specimen	Aperture	Seal description	Service insulation	FRL
a pipe wall thickness of 10.0 mm		Protecta FR Collar 110 mm fitted both faces (size 6 mm thick × 30 mm deep). Protecta FR Acrylic fitted on both faces (size 2 mm wide × 2 mm deep).		
P – PP pipe with an outer diameter of Ø 50 mm and a pipe wall thickness of 4.6 mm	Ø 54 mm	Pipe capping: U/U Protecta FR Collar 50 mm fitted both faces (size 3 mm thick × 30 mm deep). Protecta FR Acrylic fitted on both faces (size 2 mm wide × 2 mm deep).	None.	-/60/45
Q – PE pipe with an outer diameter of Ø 50 mm and a pipe wall thickness of 3.0 mm	Ø 54 mm	Pipe capping: U/C Protecta FR Collar 50 mm fitted both faces (size 3 mm thick × 30 mm deep). Protecta FR Acrylic fitted on both faces (size 2 mm wide × 2 mm deep).	None.	-/60/45
R – PE pipe with an outer diameter of Ø 110 mm and a pipe wall thickness of 3.4 mm	Ø 114 mm	Pipe capping: U/C Protecta FR Collar 110 mm fitted both faces (size 6 mm thick × 30 mm deep). Protecta FR Acrylic fitted on both faces (size 2 mm wide × 2 mm deep).	None.	-/60/60
S – PE pipe with an outer diameter of Ø 50 mm and a pipe wall thickness of 4.6 mm	Ø 54 mm	Pipe capping: U/C Protecta FR Collar 50 mm fitted both faces (size 3 mm thick × 30 mm deep). Protecta FR Acrylic fitted on both faces (size 2 mm wide × 2 mm deep).	None.	-/60/30
T – PE pipe with an outer diameter of Ø 110 mm and a pipe wall thickness of 10.0 mm	Ø 114 mm	Pipe capping: U/C Protecta FR Collar 110 mm fitted both faces (size 6 mm thick × 30 mm deep). Protecta FR Acrylic fitted on both faces (size 2 mm wide × 2 mm deep).	None.	-/60/60
U – PE pipe with an outer diameter of Ø 160 mm and a pipe wall thickness of 9.5 mm	Ø 164 mm	Pipe capping: U/C Protecta FR Collar 160 mm fitted both faces (size 15 mm thick × 60 mm deep). Protecta FR Acrylic fitted on both faces (size 2 mm wide × 2 mm deep).	None.	-/60/60

B.2 Test report – WF 427934

Table 84 Information about test report WF 427934

Item	Information about test report
Report sponsor	Polyseam Ltd, St Andrews Road, Huddersfield, West Yorkshire, HD1, 6SB, UK.
Test laboratory	Warringtonfire, Chiltern House, Stocking Lane, High Wycombe, HP14, 4ND, UK.
Test date	The fire resistance test was completed on 14 April 2020.
Test standards	The test was done in accordance with BS EN 1363-1:2012 and BS EN 1366-3:2009.
Variation to test standards	None
General description of tested specimen	<p>The supporting construction comprised of a 3000 mm wide × 3000 mm high steel stud / plasterboard clad partition. The partition framing consisted of 50 mm wide C-section studs at 600 mm centres with 50 mm thick 33 kg/m³ density mineral wool insulation friction fitted between the studs, and clad on both faces with 2 layers of 12.5 mm thick Type F plasterboard.</p> <p>The services referenced in this assessment report are referenced in Table 85. All pipes and cables measured 1200 mm long with a minimum of 500 mm protruding from the exposed face.</p>
Instrumentation	The test report states that the instrumentation was in accordance with BS EN 1363-1:2012 and BS EN 1366-3:2009.

The test specimen achieved the following results – see Table 85.

Table 85 Results summary for this test report

Specimen	Aperture	Seal description	Service insulation	FRL
F – Gerberit Mepla pipe with an outer diameter of Ø 16 mm and a pipe wall thickness of 2.25 mm	Ø 38 mm	<p>Pipe capping: C/C</p> <p>Protecta FR Collar 40 mm fitted both faces (size 30 mm wide × 3 mm thick).</p> <p>Protecta FR Acrylic fitted on both faces (size 2 mm wide × 2 mm deep).</p>	9 mm thick elastomeric continuous sustained.	-/90/90
H – Copper pipe with an outer diameter of Ø 54 mm and a pipe wall thickness of 1.2 mm	Ø 76 mm	<p>Pipe capping: C/C</p> <p>Protecta FR Collar 75 mm fitted both faces (size 50 mm wide × 4.2 mm thick).</p> <p>Protecta FR Acrylic fitted on both faces (size 2 mm wide × 2 mm deep).</p>	9 mm thick Armaflex elastomeric continuous sustained.	-/90/60
I – Mix bundle of PVC, PE, PP and some F type cables with an outer diameter of Ø 110 mm	Ø 110 mm	<p>Pipe capping: U/C</p> <p>Protecta FR Collar 110 mm fitted both faces (size 50 mm wide × 6 mm thick).</p> <p>Protecta FR Acrylic fitted around outside gaps between pipes (size 2 mm wide × 2 mm deep).</p>	None.	-/90/90
J Mix bundle of PVC, PE, PP and some F type cables	Ø 160 mm	<p>Pipe capping: U/C</p> <p>Protecta FR Collar 160 mm fitted around</p>	None.	-/90/90

Specimen	Aperture	Seal description	Service insulation	FRL
		pipe bundles on both faces (size 60 mm wide × 15 mm thick). Protecta FR Acrylic continuous bead with nominally 10 mm deep in between outside pipes gaps and aperture		
L – PE pipe with an outer diameter of Ø 50 mm and a pipe wall thickness of 3.0 mm	Ø 74 mm	Pipe capping: C/C Protecta FR Collar 75 mm fitted both faces (size 50 mm wide × 4.2 mm thick). Protecta FR Acrylic (size 3 mm wide × 3 mm deep).	9 mm thick Armaflex elastomeric continuous sustained.	-/90/90
M – PE pipe with an outer diameter of Ø 50 mm and a pipe wall thickness of 4.6 mm	Ø 74 mm	Pipe capping: C/C Protecta FR Collar 75 mm fitted both faces (size 50 mm wide × 4.2 mm thick). Protecta FR Acrylic (size 3 mm wide × 3 mm deep).	9 mm thick Armaflex elastomeric continuous sustained.	-/90/90
N – PP pipe with an outer diameter of Ø 50 mm and a pipe wall thickness of 1.8 mm	Ø 74 mm	Pipe capping: C/C Protecta FR Collar 75 mm fitted both faces (size 50 mm wide × 4.2 mm thick). Protecta FR Acrylic (size 3 mm wide × 3 mm deep).	9 mm thick Armaflex elastomeric continuous sustained.	-/90/90
O – PP pipe with an outer diameter of Ø 50 mm and a pipe wall thickness of 4.6 mm	Ø 74 mm	Pipe capping: C/C Protecta FR Collar 75 mm fitted both faces (size 50 mm wide × 4.2 mm thick). Protecta FR Acrylic (size 3 mm wide × 3 mm deep).	9 mm thick Armaflex elastomeric continuous sustained.	-/90/90

B.3 Test report – WF 415582

Table 86 Information about test report WF 415582

Item	Information about test report
Report sponsor	Polyseam Ltd, St Andrews Road, Huddersfield, West Yorkshire, HD1, 6SB, UK.
Test laboratory	Warringtonfire, Chiltern House, Stocking Lane, High Wycombe, HP14, 4ND, UK.
Test date	The fire resistance test was completed on 16 July 2019.
Test standards	The test was done in accordance with BS EN 1363-1:2012, BS EN 1366-3:2009 and BS EN 1366-4:2006+A1:2010.
Variation to test standards	None
General description of tested specimen	<p>The supporting construction comprised of a 3000 mm wide × 3000 mm high steel stud / plasterboard clad partition. The partition framing consisted of 50 mm wide C-section studs at 600 mm centres with 50 mm thick 35 kg/m³ density mineral wool insulation friction fitted between the studs, and clad on both faces with 2 layers of 12.5 mm thick Type F plasterboard.</p> <p>The services referenced in this assessment report are referenced in Table 87. All pipes and cables measured 1200 mm long with a minimum of 500 mm protruding from the exposed face.</p>
Instrumentation	The test report states that the instrumentation was in accordance with BS EN 1363-1:2012 and BS EN 1366-3:2009.

The test specimen achieved the following results – see Table 87.

Table 87 Results summary for this test report

Specimen	Aperture	Seal description	Service insulation	FRL
A – PVC pipe with an outer diameter of Ø 200 mm and a pipe wall thickness of 4.9 mm	Ø 204 mm	<p>Pipe capping: U/C</p> <p>Protecta FR Collar 200 mm fitted both faces (size 60 mm wide × 18 mm thick).</p> <p>Protecta FR Acrylic between pipe and wall (size 2 mm wide × 2 mm deep).</p>	None.	-/120/120
B – PVC pipe with an outer diameter of Ø 400 mm and a pipe wall thickness of 9.8 mm	Ø 404 mm	<p>Pipe capping: C/C</p> <p>Protecta FR Collar 400 mm fitted both faces (size 100 mm wide × 40 mm thick).</p> <p>Protecta FR Acrylic between pipe and wall (size 2 mm wide × 2 mm deep).</p>	None.	-/120/90
E – Geberit Mepla pipe with an outer diameter of Ø 76 mm and a pipe wall thickness of 4.6 mm	Ø 204 mm	<p>Pipe capping: C/C</p> <p>Protecta FR Collar 200 mm fitted both faces (size 60 mm wide × 18 mm thick).</p> <p>Protecta FR Acrylic (size 14.5 mm wide × 25 mm deep).</p>	50 mm thick K-Flex Elastomeric foam insulation – (continuous sustained)	-/120/90
F – PP pipe with an outer diameter of Ø 200 mm and a pipe wall thickness of 4.9 mm	Ø 204 mm	<p>Pipe capping: U/C</p> <p>Protecta FR Collar 200 mm fitted both faces (size 60 mm wide × 18 mm thick).</p> <p>Protecta FR Acrylic between pipe and wall (size 2 mm wide × 2 mm deep).</p>	None.	-/120/90

Specimen	Aperture	Seal description	Service insulation	FRL
G – PP pipe with an outer diameter of Ø 200 mm and a pipe wall thickness of 18.2 mm	Ø 204 mm	Pipe capping: U/C Protecta FR Collar 200 mm fitted both faces (size 60 mm wide × 18 mm thick). Protecta FR Acrylic between pipe and wall (size 2 mm wide × 2 mm deep).	None.	-/120/90
H – PE pipe with an outer diameter of Ø 200 mm and a pipe wall thickness of 6.2 mm	Ø 204 mm	Pipe capping: U/C Protecta FR Collar 200 mm fitted both faces (size 60 mm wide × 18 mm thick). Protecta FR Acrylic between pipe and wall (size 2 mm wide × 2 mm deep).	None.	-/120/90
I – PVC pipe with an outer diameter of Ø 315 mm and a pipe wall thickness of 7.7 mm	Ø 320 mm	Pipe capping: C/C Protecta FR Collar 315 mm fitted both faces (size 75 mm wide × 30 mm thick). Protecta FR Acrylic between pipe and wall (size 2 mm wide × 2 mm deep).	None.	-/90/90
J – PE pipe with an outer diameter of Ø 400 mm and a pipe wall thickness of 36.3 mm	Ø 404 mm	Pipe capping: C/C Protecta FR Collar 400 mm fitted both faces (size 100 mm wide × 40 mm thick). Protecta FR Acrylic between pipe and wall (size 2 mm wide × 2 mm deep).	None.	-/90/90
K – PVC pipe with an outer diameter of Ø 315 mm and a pipe wall thickness of 12.1 mm	Ø 320 mm	Pipe capping: C/C Protecta FR Collar 315 mm fitted both faces (size 75 mm wide × 30 mm thick). Protecta FR Acrylic between pipe and wall (size 2 mm wide × 2 mm deep).	None.	-/120/90
L – PE pipe with an outer diameter of Ø 200 mm and a pipe wall thickness of 18.2 mm	Ø 204 mm	Pipe capping: U/C Protecta FR Collar 200 mm fitted both faces (size 60 mm wide × 18 mm thick). Protecta FR Acrylic between pipe and wall (size 2 mm wide × 2 mm deep).	None.	-/120/90

B.4 Test report – WF 417693

Table 88 Information about test report WF 417693

Item	Information about test report
Report sponsor	Polyseam Ltd, St Andrews Road, Huddersfield, West Yorkshire, HD1, 6SB, UK.
Test laboratory	Warringtonfire, Chiltern House, Stocking Lane, High Wycombe, HP14, 4ND, UK.
Test date	The fire resistance test was completed on 17 September 2019.
Test standards	The test was done in accordance with BS EN 1363-1:2012 and BS EN 1366-3:2009.
Variation to test standards	None
General description of tested specimen	<p>The supporting construction comprised of a 3000 mm wide × 3000 mm high steel stud / plasterboard clad partition.</p> <p>The partition framing consisted of 50 mm wide C-section studs at 600 mm centres with 50 mm thick 33 kg/m³ density mineral wool insulation friction fitted between the studs, and clad on both faces with 1 layer of 12.5 mm thick Type F plasterboard.</p> <p>The services referenced in this assessment report are referenced in Table 89. All pipes and cables measured 1200 mm long with a minimum of 500 mm protruding from the exposed face.</p>
Instrumentation	The test report states that the instrumentation was in accordance with BS EN 1363-1:2012 and BS EN 1366-3:2009.

The test specimen achieved the following results – see Table 89.

Table 89 Results summary for this test report

Specimen	Aperture	Seal description	Service insulation	FRL
A – PVC pipe with an outer diameter of Ø 200 mm and a pipe wall thickness of 11.9 mm	Ø 204 mm	<p>Pipe capping: U/C</p> <p>Protecta FR Collar 200 mm fitted both faces (size 60 mm wide × 18 mm thick).</p> <p>Protecta FR Acrylic sealing pipe to plasterboard (size 2 mm wide × 2 mm deep).</p>	None	-/120/120
C – PP pipe with an outer diameter of Ø 400 mm and a pipe wall thickness of 22.7 mm	Ø 404 mm	<p>Pipe capping: C/C</p> <p>Protecta FR Collar 400 mm fitted both faces (size 100 mm wide × 40 mm thick).</p> <p>Protecta FR Acrylic sealing pipe to plasterboard (size 2 mm wide × 2 mm deep).</p>	None	-/60/60
F – PE pipe with an outer diameter of Ø 160 mm and a pipe wall thickness of 9.5 mm	Ø 265 mm	<p>Pipe capping: C/C</p> <p>Protecta FR Collar 315 mm fitted both faces (size 75 mm wide × 30 mm thick).</p> <p>Protecta FR Acrylic sealing pipe to plasterboard (size 2.5 mm wide × 2.5 mm deep).</p>	50 mm thick Armaflex Ace Elastomeric foam.	-/120/120
G – PP pipe with an outer diameter of Ø 160 mm and a pipe wall thickness of 14.6 mm	Ø 265 mm	<p>Pipe capping: C/C</p> <p>Protecta FR Collar 315 mm fitted both faces (size 75 mm wide × 30 mm thick).</p>	50 mm thick Armaflex Ace Elastomeric foam.	-/120/120

Specimen	Aperture	Seal description	Service insulation	FRL
		Protecta FR Acrylic sealing pipe insulation to plasterboard (size 2.5 mm wide × 2.5 mm deep).		
H – PE pipe with an outer diameter of Ø 160 mm and a pipe wall thickness of 4.9 mm	Ø 265 mm	Pipe capping: C/C Protecta FR Collar 315 mm fitted both faces (size 75 mm wide × 30 mm thick). Protecta FR Acrylic sealing pipe insulation to plasterboard (size 2.5 mm wide × 2.5 mm deep).	50 mm thick Armaflex Ace Elastomeric foam.	-/120/120
K – PVC pipe with an outer diameter of Ø 400 mm and a pipe wall thickness of 11.9 mm	Ø 404 mm	Pipe capping: C/C Protecta FR Collar 400 mm fitted both faces (size 100 mm wide × 40 mm thick). Protecta FR Acrylic sealing pipe to plasterboard (size 2 mm wide × 2 mm deep).	None.	-/120/120
L – PP pipe with an outer diameter of Ø 160 mm and a pipe wall thickness of 4.9 mm	Ø 265 mm	Pipe capping: C/C Protecta FR Collar 315 mm fitted both faces (size 75 mm wide × 30 mm thick). Protecta FR Acrylic sealing pipe insulation to plasterboard (size 2.5 mm wide × 2.5 mm deep).	50 mm thick Armaflex Ace Elastomeric foam.	-/120/120

B.5 Test report – WF 408361

Table 90 Information about test report WF 408361

Item	Information about test report
Report sponsor	Polyseam Ltd, St Andrews Road, Huddersfield, West Yorkshire, HD1, 6SB, UK.
Test laboratory	Warringtonfire, Chiltern House, Stocking Lane, High Wycombe, HP14, 4ND, UK.
Test date	The fire resistance test was completed on 18 December 2018.
Test standards	The test was done in accordance with BS EN 1363-1:2012 and BS EN 1366-3:2009.
Variation to test standards	None
General description of tested specimen	<p>The supporting construction comprised of a 3000 mm wide × 3000 mm high steel stud / plasterboard clad partition. The partition framing consisted of 50 mm wide C-section studs at 600 mm centres with 50 mm thick 35 kg/m³ density mineral wool insulation friction fitted between the studs, and clad on both faces with 1 layer of 12.5 mm thick Type F plasterboard.</p> <p>The services referenced in this assessment report are referenced in Table 91. All pipes and cables measured 1200 mm long with a minimum of 500 mm protruding from the exposed face.</p>
Instrumentation	The test report states that the instrumentation was in accordance with BS EN 1363-1:2012 and BS EN 1366-3:2009.

The test specimen achieved the following results – see Table 91.

Table 91 Results summary for this test report

Specimen	Aperture	Seal description	Service insulation	FRL
A – PE pipe with an outer diameter of Ø 160 mm and a pipe wall thickness of 4.9 mm	Ø 180 mm	<p>Pipe capping: C/C</p> <p>Protecta FR Collar 200 mm on both faces (size 60 mm wide × 18 mm thick).</p> <p>Protecta FR Acrylic (1 mm wide × 1 mm deep between pipe insulation and wall).</p>	9 mm thick foam – Armaflex ACE elastomeric insulation foam (continuous sustained).	-/120/120
D – Uponor Decibel pipe with an outer diameter of Ø 50 mm and a pipe wall thickness of 2.0 mm	Ø 52 mm	<p>Pipe capping: U/U</p> <p>Protecta FR Collar 55 mm on both faces (size 50 mm wide × 3.2 mm thick).</p> <p>Protecta FR Acrylic (1 mm wide × 1 mm deep).</p>	None.	-/120/60
G – PE pipe with an outer diameter of Ø 160 mm and a pipe wall thickness of 9.5 mm	Ø 180 mm	<p>Pipe capping: C/C</p> <p>Protecta FR Collar 200 mm on both faces (size 60 mm wide × 18 mm thick).</p> <p>Protecta FR Acrylic (1 mm wide × 1 mm deep).</p>	9 mm thick foam – Armaflex ACE elastomeric foam insulation – (continuous sustained).	-/120/120
H – Geberit Mepla MLC pipe with an outer diameter of Ø 75 mm and a pipe wall thickness of 4.6 mm	Ø 95 mm	<p>Pipe capping: C/C</p> <p>Protecta FR Collar 110 mm on both faces (size 50 mm wide × 6 mm thick).</p> <p>Protecta FR Acrylic (1 mm wide × 1 mm deep).</p>	9 mm thick Kaiflex ST elastomeric foam insulation – (continuous sustained).	-/120/60
J – PP pipe with an outer diameter of Ø 160 mm and a pipe	Ø 180 mm	<p>Pipe capping: C/C</p> <p>Protecta FR Collar 200 mm on both faces (size 60 mm wide × 18 mm thick).</p>	9 mm thick Armaflex ACE elastomeric foam insulation – (continuous sustained).	-/120/120

Specimen	Aperture	Seal description	Service insulation	FRL
wall thickness of 4.9 mm		Protecta FR Acrylic (1 mm wide × 1 mm deep).		
K – Copper pipe with an outer diameter of Ø 12 mm and a pipe wall thickness of 0.7 mm	Ø 32 mm	Pipe capping: C/C Protecta FR Collar 32 mm on both faces (size 30 mm wide × 3 mm thick).	9 mm thick Kaiflex ST elastomeric foam insulation – (continuous sustained).	-/120/90
M – PP pipe with an outer diameter of Ø 160 mm and a pipe wall thickness of 14.6 mm	Ø 180 mm	Pipe capping: C/C Protecta FR Collar 200 mm on both faces (size 60 mm wide × 18 mm thick). Protecta FR Acrylic (1 mm wide × 1 mm deep).	9 mm thick Armaflex ACE elastomeric foam insulation – (continuous sustained).	-/120/120
O – Copper pipe with an outer diameter of Ø 54 mm and a pipe wall thickness of 1.2 mm	Ø 160 mm	Pipe capping: C/C Protecta FR Collar 160 mm on both faces (size 60 mm wide × 15 mm thick). Protecta FR Acrylic (3 mm wide × 3 mm deep).	50 mm thick Kaiflex ST elastomeric foam insulation – (continuous sustained).	-/120/60
Q – Uponor Decibel pipe with an outer diameter of Ø 110 mm and a pipe wall thickness of 3.8 mm	Ø 112 mm	Pipe capping: U/U Protecta FR Collar 110 mm on both faces (size 50 mm wide × 6 mm thick). Protecta FR Acrylic (1 mm wide × 1 mm deep).	None.	-/120/60

B.6 Test report – WF 407685

Table 92 Information about test report WF 407685

Item	Information about test report
Report sponsor	Polyseam Ltd, St Andrews Road, Huddersfield, West Yorkshire, HD1, 6SB, UK.
Test laboratory	Warringtonfire, Chiltern House, Stocking Lane, High Wycombe, HP14, 4ND, UK.
Test date	The fire resistance test was completed on 29 November 2018.
Test standards	The test was done in accordance with BS EN 1363-1:2012 and BS EN 1366-3:2009.
Variation to test standards	None
General description of tested specimen	<p>The supporting construction comprised of a 3000 mm wide × 3000 mm high steel stud / plasterboard clad partition. The partition framing consisted of 50 mm wide C-section studs at 600 mm centres with 50 mm thick 33 kg/m³ density mineral wool insulation friction fitted between the studs, and clad on both faces with 1 layer of 12.5 mm thick Type F plasterboard.</p> <p>The services referenced in this assessment report are referenced in Table 93. All pipes and cables measured 1200 mm long with a minimum of 500 mm protruding from the exposed face.</p>
Instrumentation	The test report states that the instrumentation was in accordance with BS EN 1363-1:2012 and BS EN 1366-3:2009.

The test specimen achieved the following results – see Table 93.

Table 93 Results summary for this test report

Specimen	Aperture	Seal description	Service insulation	FRL
K – PE pipe with an outer diameter of Ø 160 mm and a pipe wall thickness of 4.9 mm	Ø 164 mm	<p>Pipe capping: C/C</p> <p>Protecta FR Collar 160 mm on both faces (size 60 mm wide × 15 mm thick).</p> <p>Protecta FR Acrylic sealing pipe to plasterboard (2 mm wide × 2 mm deep).</p>	None.	-/120/120

B.7 Test report – WF 427953

Table 94 Information about test report WF 427953

Item	Information about test report
Report sponsor	Polyseam Ltd, St Andrews Road, Huddersfield, West Yorkshire, HD1, 6SB, UK.
Test laboratory	Warringtonfire, Chiltern House, Stocking Lane, High Wycombe, HP14, 4ND, UK.
Test date	The fire resistance test was completed on 30 March 2020.
Test standards	The test was done in accordance with BS EN 1363-1:2012 and BS EN 1366-3:2009.
Variation to test standards	None
General description of tested specimen	The supporting construction comprised of a 1500 mm wide × 1500 mm high × 150 mm thick reinforced AAC block wall. The services referenced in this assessment report are referenced in Table 95. All pipes and cables measured 1200 mm long with a minimum of 500 mm protruding from the exposed face.
Instrumentation	The test report states that the instrumentation was in accordance with BS EN 1363-1:2012 and BS EN 1366-3:2009.

The test specimen achieved the following results – see Table 95.

Table 95 Results summary for this test report

Specimen	Aperture	Seal description	Service insulation	FRL
D – PE pipe with an outer diameter of Ø 50 mm and a pipe wall thickness of 4.6 mm	Ø 50 mm	Pipe capping: U/C Protecta FR Collar 50 mm (size 3 mm thick × 50 mm wide). Protecta FR Acrylic sealing the inside edge of the collar to the pipe, sealing the joints in the collar and sealing the collar shell edge to the wall (size 2 mm deep × 3.5 mm wide).	None.	-/180/120
F – PP pipe with an outer diameter of Ø 50 mm and a pipe wall thickness of 4.6 mm	Ø 57 mm	Pipe capping: U/C Protecta FR Collar 50 mm (size 3 mm thick × 50 mm wide). Protecta FR Acrylic sealing the inside edge of the collar to the pipe, sealing the joints in the collar and sealing the collar shell edge to the wall (size 2 mm deep × 3.5 mm wide).	None.	-/90/90
G – PE pipe with an outer diameter of Ø 50 mm and a pipe wall thickness of 3 mm	Ø 57 mm	Pipe capping: U/C Protecta FR Collar 50 mm (size 3 mm thick × 50 mm wide). Protecta FR Acrylic sealing the inside edge of the collar to the pipe, sealing the joints in the collar and sealing the collar shell edge to the wall (size 2 mm deep × 3.5 mm wide).	None.	-/240/120
J – PVC pipe with an outer diameter of Ø 50 mm and a pipe wall thickness of 3.7 mm	Ø 57 mm	Pipe capping: U/C Protecta FR Collar 50 mm (size 3 mm thick × 50 mm wide). Protecta FR Acrylic sealing the inside edge of the collar to the pipe, sealing the joints in the collar and	None.	-/240/180

Specimen	Aperture	Seal description	Service insulation	FRL
		sealing the collar shell edge to the wall (size 2 mm deep × 3.5 mm wide).		
K – PE pipe with an outer diameter of Ø 110 mm and a pipe wall thickness of 3.4 mm	Ø 114 mm	Pipe capping: U/C Protecta FR Collar 110 mm (size 6 mm thick × 50 mm wide). Protecta FR Acrylic sealing the inside edge of the collar to the pipe, sealing the joints in the collar and sealing the collar shell edge to the wall (size 2 mm deep × 2 mm wide).	None.	-/90/90
M – PVC pipe with an outer diameter of Ø 50 mm and a pipe wall thickness of 2.4 mm	Ø 57 mm	Pipe capping: U/C Protecta FR Collar 50 mm (size 3 mm thick × 50 mm wide). Protecta FR Acrylic sealing the inside edge of the collar to the pipe, sealing the joints in the collar and sealing the collar shell edge to the wall (size 2 mm deep × 3.5 mm wide).	None.	-/240/180
N – PVC pipe with an outer diameter of Ø 110 mm and a pipe wall thickness of 6.6 mm	Ø 114 mm	Pipe capping: U/C Protecta FR Collar 110 mm (size 6 mm thick × 50 mm wide). Protecta FR Acrylic sealing the inside edge of the collar to the pipe, sealing the joints in the collar and sealing the collar shell edge to the wall (size 2 mm deep × 2 mm wide).	None.	-/180/180
P – PP pipe with an outer diameter of Ø 50 mm and a pipe wall thickness of 2 mm	Ø 57 mm	Pipe capping: U/C Protecta FR Collar 50 mm (size 3 mm thick × 50 mm wide). Protecta FR Acrylic sealing the inside edge of the collar to the pipe, sealing the joints in the collar and sealing the collar shell edge to the wall (size 2 mm deep × 3.5 mm wide).	None.	-/240/240

B.8 Test report – WF 419764

Table 96 Information about test report WF 419764

Item	Information about test report
Report sponsor	Polyseam Ltd, St Andrews Road, Huddersfield, West Yorkshire, HD1, 6SB, UK.
Test laboratory	Warringtonfire, Chiltern House, Stocking Lane, High Wycombe, HP14, 4ND, UK.
Test date	The fire resistance test was completed on 12 December 2019.
Test standards	The test was done in accordance with BS EN 1363-1:2012 and BS EN 1366-3:2009.
Variation to test standards	None
General description of tested specimen	The supporting construction comprised of a 3000 mm wide × 3000 mm high × 150 mm thick blockwork wall. The services referenced in this assessment report are referenced in Table 97. All pipes and cables measured 1200 mm long with a minimum of 500 mm protruding from the exposed face.
Instrumentation	The test report states that the instrumentation was in accordance with BS EN 1363-1:2012 and BS EN 1366-3:2009.

The test specimen achieved the following results – see Table 97.

Table 97 Results summary for this test report

Specimen	Aperture	Seal description	Service insulation	FRL
I – PVC pipe with an outer diameter of Ø 110 mm and a pipe wall thickness of 3.2 mm	Ø 114 mm	Pipe capping: U/C Protecta FR Collar 110 mm fitted on the exposed face (size 6 mm thick × 50 mm wide). Protecta FR Acrylic sealing pipe to collar, joints to the collar and collar to wall (nominal 2 mm continuous bead).	None.	-/240/240

B.9 Test report – WF 422787

Table 98 Information about test report WF 422787

Item	Information about test report
Report sponsor	Polyseam Ltd, St Andrews Road, Huddersfield, West Yorkshire, HD1, 6SB, UK.
Test laboratory	Warringtonfire, Chiltern House, Stocking Lane, High Wycombe, HP14, 4ND, UK.
Test date	The fire resistance test was completed on 22 January 2020.
Test standards	The test was done in accordance with BS EN 1363-1:2012 and BS EN 1366-3:2009.
Variation to test standards	None
General description of tested specimen	The supporting construction comprised of a 1500 mm wide × 1500 mm high × 150 mm thick reinforced AAC blocks. The services referenced in this assessment report are referenced in Table 99. All pipes and cables measured 1200 mm long with a minimum of 500 mm protruding from the exposed face.
Instrumentation	The test report states that the instrumentation was in accordance with BS EN 1363-1:2012 and BS EN 1366-3:2009.

The test specimen achieved the following results – see Table 99.

Table 99 Results summary for this test report

Specimen	Aperture	Seal description	Service insulation	FRL
A – PVC pipe with an outer diameter of Ø 160 mm and a pipe wall thickness of 9.5 mm	Ø 165 mm	Pipe capping: U/C Protecta FR Collar 160 mm (size 15 mm thick × 60 mm wide). Protecta FR Acrylic sealing the inside edge of the collar to the pipe, sealing the joints in the collar and sealing the collar shell edge to the wall (size 2.5 mm thick).	None.	-/240/180
C – PE pipe with an outer diameter of Ø 110 mm and a pipe wall thickness of 10 mm	Ø 110 mm	Pipe capping: U/C Protecta FR Collar 110 mm (size 6 mm thick × 50 mm wide). Protecta FR Acrylic sealing the inside edge of the collar to the pipe, sealing the joints in the collar and sealing the collar shell edge to the wall (size 2 mm thick).	None.	-/180/120
D – PE pipe with an outer diameter of Ø 50 mm and a pipe wall thickness of 4.6 mm	Ø 57 mm	Pipe capping: U/C Protecta FR Collar 50 mm (size 3 mm thick × 50 mm wide). Protecta FR Acrylic sealing the inside edge of the collar to the pipe, sealing the joints in the collar and sealing the collar shell edge to the wall (size 2 mm thick).	None.	-/240/240
F – PP pipe with an outer diameter of Ø 50 mm and a pipe wall thickness of 4.6 mm	Ø 57 mm	Pipe capping: U/C Protecta FR Collar 50 mm (size 3 mm thick × 50 mm wide). Protecta FR Acrylic sealing the inside edge of the collar to the pipe, sealing the joints in the collar and sealing the collar shell	None.	-/240/240

Specimen	Aperture	Seal description	Service insulation	FRL
		edge to the wall (size 2 mm thick).		
G – PP pipe with an outer diameter of Ø 50 mm and a pipe wall thickness of 3 mm	Ø 50 mm	Pipe capping: U/C Protecta FR Collar 50 mm (size 3 mm thick × 50 mm wide). Protecta FR Acrylic sealing the inside edge of the collar to the pipe, sealing the joints in the collar and sealing the collar shell edge to the wall (size 2 mm thick).	None.	-/240/240
H – PVC pipe with an outer diameter of Ø 160 mm and a pipe wall thickness of 4 mm	Ø 165 mm	Pipe capping: U/C Protecta FR Collar 160 mm (size 15 mm thick × 60 mm wide). Protecta FR Acrylic sealing the inside edge of the collar to the pipe, sealing the joints in the collar and sealing the collar shell edge to the wall (size 2 mm thick).	None.	-/120/120
I – PE pipe with an outer diameter of Ø 110 mm and a pipe wall thickness of 3.4 mm	Ø 110 mm	Pipe capping: U/C Protecta FR Collar 110 mm (size 6 mm thick × 50 mm wide). Protecta FR Acrylic sealing the inside edge of the collar to the pipe, sealing the joints in the collar and sealing the collar shell edge to the wall (size 2 mm thick).	None.	-/240/90
K – PVC pipe with an outer diameter of Ø 50 mm and a pipe wall thickness of 3.7 mm	Ø 57 mm	Pipe capping: U/C Protecta FR Collar 50 mm (size 3 mm thick × 50 mm wide). Protecta FR Acrylic sealing the inside edge of the collar to the pipe, sealing the joints in the collar and sealing the collar shell edge to the wall (size 2 mm thick).	None.	-/240/240
L – PP pipe with an outer diameter of Ø 50 mm and a pipe wall thickness of 2 mm	Ø 57 mm	Pipe capping: U/C Protecta FR Collar 50 mm (size 3 mm thick × 50 mm wide). Protecta FR Acrylic sealing the inside edge of the collar to the pipe, sealing the joints in the collar and sealing the collar shell edge to the wall (size 2 mm thick).	None.	-/240/180
N – PVC pipe with an outer diameter of Ø 50 mm and a pipe wall thickness of 2.4 mm	Ø 57 mm	Pipe capping: U/C Protecta FR Collar 50 mm (size 3 mm thick × 50 mm wide). Protecta FR Acrylic sealing the inside edge of the collar to the pipe, sealing the joints in the collar and sealing the collar shell edge to the wall (size 2 mm thick).	None.	-/240/240

Specimen	Aperture	Seal description	Service insulation	FRL
O – PVC pipe with an outer diameter of Ø 110 mm and a pipe wall thickness of 6.6 mm	Ø 114 mm	Pipe capping: U/C Protecta FR Collar 110 mm (size 6 mm thick × 50 mm wide). Protecta FR Acrylic sealing the inside edge of the collar to the pipe, sealing the joints in the collar and sealing the collar shell edge to the wall (size 2 mm thick).	None.	-/240/120
P – PVC pipe with an outer diameter of Ø 160 mm and a pipe wall thickness of 4 mm	Ø 165 mm	Pipe capping: U/C Protecta FR Collar 160 mm (size 15 mm thick × 60 mm wide). Protecta FR Acrylic sealing the inside edge of the collar to the pipe, sealing the joints in the collar and sealing the collar shell edge to the wall (size 2 mm thick).	None.	-/240/120
Q – PVC pipe with an outer diameter of Ø 160 mm and a pipe wall thickness of 9.5 mm	Ø 165 mm	Pipe capping: U/C Protecta FR Collar 160 mm (size 15 mm thick × 60 mm wide). Protecta FR Acrylic sealing the inside edge of the collar to the pipe, sealing the joints in the collar and sealing the collar shell edge to the wall (size 2 mm thick).	None.	-/120/120

B.10 Test report – WF 405608

Table 100 Information about test report WF 405608

Item	Information about test report
Report sponsor	Polyseam Ltd, St Andrews Road, Huddersfield, West Yorkshire, HD1, 6SB, UK.
Test laboratory	Warringtonfire, Chiltern House, Stocking Lane, High Wycombe, HP14, 4ND, UK.
Test date	The fire resistance test was completed on 9 October 2018.
Test standards	The test was done in accordance with BS EN 1363-1:2012 and BS EN 1366-3:2009.
Variation to test standards	None
General description of tested specimen	The supporting construction comprised of a 1500 mm wide × 1500 mm high × 150 mm thick reinforced AAC blocks. The services referenced in this assessment report are referenced in Table 101. All pipes and cables measured 1200 mm long with a minimum of 500 mm protruding from the exposed face.
Instrumentation	The test report states that the instrumentation was in accordance with BS EN 1363-1:2012 and BS EN 1366-3:2009.

The test specimen achieved the following results – see Table 101.

Table 101 Results summary for this test report

Specimen	Aperture	Seal description	Service insulation	FRL
B – PE pipe with an outer diameter of Ø 110 mm and a pipe wall thickness of 6.6 mm	Ø 114 mm	Pipe capping: U/C Protecta FR Collar 110 mm (size 6 mm thick × 50 mm wide). Protecta FR Acrylic sealed flush (size 2 mm thick).	None.	-/180/120

B.11 Test report – WF 427717

Table 102 Information about test report WF 427717

Item	Information about test report
Report sponsor	Polyseam Ltd, St Andrews Road, Huddersfield, West Yorkshire, HD1, 6SB, UK.
Test laboratory	Warringtonfire, Chiltern House, Stocking Lane, High Wycombe, HP14, 4ND, UK.
Test date	The fire resistance test was completed on 24 March 2020.
Test standards	The test was done in accordance with BS EN 1363-1:2012 and BS EN 1366-3:2009.
Variation to test standards	None
General description of tested specimen	The supporting construction comprised of reinforced AAC lintel floor slab built on top of a 1.5 m × 1.5 m. The services referenced in this assessment report are referenced in Table 103. All pipes and cables measured 1200 mm long with a minimum of 500 mm protruding from the exposed face.
Instrumentation	The test report states that the instrumentation was in accordance with BS EN 1363-1:2012 and BS EN 1366-3:2009.

The test specimen achieved the following results – see Table 103.

Table 103 Results summary for this test report

Specimen	Aperture	Seal description	Service insulation	FRL
A – PE, PVC and PP pipe bundle with an outer diameter of Ø 160 mm and a pipe wall thickness of 6.6 mm	Ø 165 mm	Pipe capping: C/U Protecta FR Collar 160 mm (size 15 mm thick × 60 mm wide). Protecta FR Acrylic 10 mm wide × 10 mm deep filling voids between pipes the edge of the aperture.	None.	-/90/90
D – Copper pipe with an outer diameter of Ø 42 mm and a pipe wall thickness of 1.2 mm	Ø 165 mm	Pipe capping: C/C Protecta FR Collar 160 mm (size 6 mm thick × 50 mm wide). Protecta FR Acrylic 11.5 mm wide × 10 mm deep filling voids between pipes the edge of the aperture.	50 mm thick Armaflex Ace Elastomeric – continuous sustained.	-/60/60
E – PP pipe with an outer diameter of Ø 110 mm and a pipe wall thickness of 4.2 mm	Ø 114 mm	Pipe capping: U/C Protecta FR Collar 110 mm (size 6 mm thick × 30 mm wide). Protecta FR Acrylic sealing the perimeter of the pipe to the inside edge of the collar where it protrudes, the joints in the collar and collar shell edge to the wall (2 mm thick).	None.	-/240/240
F – Copper pipe with an outer diameter of Ø 42 mm and a pipe wall thickness of 1.2 mm	Ø 65 mm	Pipe capping: C/C Protecta FR Collar 63 mm (size 3.6 mm thick × 50 mm wide).	9 mm thick Armaflex Elastomeric – continuous sustained.	-/180/120

Specimen	Aperture	Seal description	Service insulation	FRL
		Protecta FR Acrylic 2.5 mm wide × 2.5 mm deep flush with the exposed face.		
G – Uponer inner pipe with an outer diameter of Ø 25 mm and a pipe wall thickness of 0.6 mm Uponer Aqua outer pipe with an outer diameter of Ø 15 mm and a pipe wall thickness of 2.5 mm	Ø 50 mm	Pipe capping: C/C Protecta FR Collar 50 mm (size 3 mm thick × 50 mm wide). Protecta FR Acrylic in gaps 10 mm deep filling voids between the pipes and the edge of the aperture flush with the exposed face.	None.	-/90/90
M – PE pipe with an outer diameter of Ø 160 mm and a pipe wall thickness of 4.9 mm	Ø 165 mm	Pipe capping: U/C Protecta FR Collar 160 mm (size 15 mm thick × 60 mm wide). Protecta FR Acrylic sealing between top of collar and pipe, outside shell and floor joints in the collars (2 mm thick).	None	-/240/120

B.12 Test report – WF 19324

Table 104 Information about test report WF 19324A

Item	Information about test report
Report sponsor	Polyseam Ltd, St Andrews Road, Huddersfield, West Yorkshire, HD1, 6SB, UK.
Test laboratory	Warringtonfire NV, Ottergemsesteenweg-Zuid 711, B-9000 Gent, Belgie.
Test date	The fire resistance test was completed on 31 October 2018 September 2019.
Test standards	The test was done in accordance with BS EN 1366-3:2009.
Variation to test standards	None
General description of tested specimen	The supporting construction comprised of a rigid floor construction of thickness 150 mm and density 550 kg/m ³ . The services referenced in this assessment report are referenced in Table 105.
Instrumentation	The test report states that the instrumentation was in accordance BS EN 1366-3:2009.

The test specimen achieved the following results – see Table 105.

Table 105 Results summary for this test report

Specimen	Aperture	Seal description	Service insulation	FRL
AA – Uponor Decibel PP-MD pipe with an outer diameter of Ø 50 mm and a pipe wall thickness of 2.0 mm	Ø 52 mm	Pipe capping: U/U FR Collar 55 mm exposed side (size 3.2 mm thick × 50 mm wide). FR Acrylic exposed side.	None.	-/180/180
AB – Geberit Mepla A PE-RT II / AI / PE-RT II pipe with an outer diameter of Ø 16 mm and a pipe wall thickness of 2.25 mm	Ø 36 mm	Pipe capping: C/C FR Collar 40 mm exposed side (size 3 mm thick × 50 mm wide). FR Acrylic exposed side.	Elastomeric 9 mm thick full length.	-/180/180
AC – Agru PE100 pipe with an outer diameter of Ø 50 mm and a pipe wall thickness of 4.6 mm	Ø 70 mm	Pipe capping: C/C FR Collar 75 mm exposed side (size 4.2 mm thick × 50 mm wide). FR Acrylic exposed side.	Elastomeric 9 mm thick full length.	-/180/180
AD – Optima PVC-U pipe with an outer diameter of Ø 160 mm and a pipe wall thickness of 6.2 mm	Ø 165 mm	Pipe capping: U/C FR Collar 160 mm unexposed side (size 15 mm thick × 60 mm wide). FR Acrylic unexposed side.	None.	-/180/90
AE – Agru PPH100 pipe with an outer diameter of Ø 160 mm and a pipe wall thickness of 9.1 mm	Ø 180 mm	Pipe capping: C/C FR Collar 200 mm exposed side (size 18 mm thick × 60 mm wide). FR Acrylic exposed side	Elastomeric 9 mm thick full length.	-/180/180
AJ – Terrain Acoustic dB12 PP / PP-M / PP pipe with an outer diameter of Ø 160 mm and a pipe wall thickness of 4.9 mm	Ø 262 mm	Pipe capping: C/C FR Collar 315 mm exposed side (size 30 mm thick × 75 mm wide). FR Acrylic exposed side	Elastomeric 50 mm thick full length (2 layers of 25 mm thick insulation).	-/60/60
AK – Uponor Decibel PP-MD pipe with an	Ø 114 mm	Pipe capping: C/U	None.	-/120/120

Specimen	Aperture	Seal description	Service insulation	FRL
outer diameter of Ø 110 mm and a pipe wall thickness of 3.8 mm		FR Collar 110 mm exposed side (size 6 mm thick x 50 mm wide). FR Acrylic exposed side.		
AL – Agru PPH100 pipe with an outer diameter of Ø 160 mm and a pipe wall thickness of 9.1 mm	Ø 262 mm	Pipe capping: C/C FR Collar 315 mm exposed side (size 30 mm thick x 75 mm wide). FR Acrylic exposed side.	Elastomeric 50 mm thick full length.	-/120/120
A – Agru PE100 pipe with an outer diameter of Ø 160 mm and a pipe wall thickness of 4.9 mm	Ø 180 mm	Pipe capping: C/C FR Collar 200 mm exposed side (size 18 mm thick x 60 mm wide). FR Acrylic exposed side.	Elastomeric 9 mm thick full length.	-/180/180
F – Agru PE100 pipe with an outer diameter of Ø 160 mm and a pipe wall thickness of 4.9 mm	Ø 264 mm	Pipe capping: C/C FR Collar 315 mm exposed side (size 30 mm thick x 75 mm wide). FR Acrylic exposed side.	Elastomeric 50 mm thick full length.	-/120/120
H – Cu pipe with an outer diameter of Ø 12 mm and a pipe wall thickness of 0.7 mm	Ø 32 mm	Pipe capping: C/C FR Collar 32 mm exposed side (size 3 mm thick x 50 mm wide). FR Acrylic exposed side.	Elastomeric 9 mm thick full length.	-/180/120
I – Agru PE100 pipe with an outer diameter of Ø 160 mm and a pipe wall thickness of 9.5 mm	Ø 264 mm	Pipe capping: C/C FR Collar 315 mm exposed side (size 30 mm thick x 75 mm wide). FR Acrylic exposed side.	Elastomeric 50 mm thick full length.	-/120/120
L – Agru PE100 pipe with an outer diameter of Ø 160 mm and a pipe wall thickness of 9.5 mm	Ø 180 mm	Pipe capping: C/C FR Collar 200 mm exposed side (size 18 mm thick x 60 mm wide). FR Acrylic exposed side.	Elastomeric 9 mm thick full length.	-/180/180
Q – Geberit Mepla A PE-RT II / AI / PE-RT II pipe with an outer diameter of Ø 75 mm and a pipe wall thickness of 4.6 mm	Ø 95 mm	Pipe capping: C/C FR Collar 110 mm exposed side (size 6 mm thick x 50 mm wide). FR Acrylic exposed side.	Elastomeric 9 mm thick full length.	-/120/120
R – Agru PPH100 pipe with an outer diameter of Ø 50 mm and a pipe wall thickness of 4.6 mm	Ø 70 mm	Pipe capping: C/C FR Collar 75 mm exposed side (size 4.2 mm thick x 50 mm wide). FR Acrylic exposed side.	Elastomeric 9 mm thick full length.	-/240/120
S – Terrain Acoustic dB12 PP/ PP-M / PP pipe with an outer diameter of Ø 50 mm and a pipe wall thickness of 1.8 mm	Ø 70 mm	Pipe capping: C/C FR Collar 75 mm exposed side (size 4.2 mm thick x 50 mm wide). FR Acrylic exposed side.	Elastomeric 9 mm thick full length.	-/180/180
T – Geberit Mepla A PE-RT II / AI / PE-RT II pipe with an outer	Ø 177 mm	Pipe capping: C/C	Elastomeric 50 mm thick full length.	-/120/90

Specimen	Aperture	Seal description	Service insulation	FRL
diameter of Ø 75 mm and a pipe wall thickness of 4.6 mm		FR Collar 200 mm exposed side (size 18 mm thick × 60 mm wide). FR Acrylic exposed side.		
W – Terrain Acoustic dB12 PP/ PP-M / PP pipe with an outer diameter of Ø 160 mm and a pipe wall thickness of 4.9 mm	Ø 180 mm	Pipe capping: C/C FR Collar 200 mm exposed side (size 18 mm thick × 60 mm wide). FR Acrylic exposed side.	Elastomeric 9 mm thick full length.	-/240/240
Z – Agru PE100 pipe with an outer diameter of Ø 50 mm and a pipe wall thickness of 3.0 mm	Ø 70 mm	Pipe capping: C/C FR Collar 75 mm exposed side (size 4.2 mm thick × 50 mm wide). FR Acrylic exposed side.	Elastomeric 9 mm thick full length.	-/180/180

B.13 Test report – WF 19221

Table 106 Information about test report WF 19221

Item	Information about test report
Report sponsor	Polyseam Ltd, St Andrews Road, Huddersfield, West Yorkshire, HD1, 6SB, UK.
Test laboratory	Warringtonfire NV, Ottergemsesteenweg-Zuid 711, B-9000 Gent, Belgie.
Test date	The fire resistance test was completed on 19 July 2018.
Test standards	The test was done in accordance with BS EN 1363-1:2012 and BS EN 1366-3:2009.
Variation to test standards	None
General description of tested specimen	The supporting construction comprised of a AAC 150 mm thick floor. The services referenced in this assessment report are referenced in Table 107.
Instrumentation	The test report states that the instrumentation was in accordance with BS EN 1363-1:2012 and BS EN 1366-3:2009.

The test specimen achieved the following results – see Table 107.

Table 107 Results summary for this test report

Specimen	Aperture	Seal description	Service insulation	FRL
Q – PP pipe with an outer diameter of Ø 110 mm and a pipe wall thickness of 6.6 mm	Ø 112 mm	Pipe capping: U/C FR Collar 110 mm exposed face (size 6 mm thick × 30 mm deep). FR Acrylic bead.	None.	-/180/180

B.14 Test report – WF 412849

Table 108 Information about test report WF 412849

Item	Information about test report
Report sponsor	Polyseam Ltd, 15 St Andrews Road, Huddersfield, West Yorkshire, HD1, 6SB, UK.
Test laboratory	Warringtonfire, Chiltern House, Stocking Lane, High Wycombe, HP14, 4ND, UK.
Test date	The fire resistance test was completed on 9 April 2019.
Test standards	The test was done in accordance with BS EN 1363-1:2012 and BS EN 1366-3:2009.
Variation to test standards	None
General description of tested specimen	<p>The supporting construction comprised of a 3000 mm wide × 3000 mm high 100 mm thick cross laminated timber wall construction. A timber section stated by the client as European redwood with a nominal density of 510 kg/m³ was used to connect the upper and lower wall sections via a loose tongue joint.</p> <p>The material is Lumber Norwegian Spruce glued with heat-resistant melamine-urea-formaldehyde from Dynea AS. The lamella thicknesses are 33 mm, 34 mm and 33 mm.</p> <p>The services referenced in this assessment report are referenced in Table 109.</p>
Instrumentation	The test report states that the instrumentation was in accordance with BS EN 1363-1:2012 and BS EN 1366-3:2009.

The test specimen achieved the following results – see Table 109.

Table 109 Results summary for this test report

Specimen	Aperture	Seal description	Service insulation	FRL
B – PVC pipe with an outer diameter of Ø 110 mm and a pipe wall thickness of 2.7 mm	Ø 130 mm	<p>Pipe capping: U/C</p> <p>Protecta FR Collar 110 mm on both faces, fixed to the wall with 80 mm long wood screws (size 50 mm deep × 6 mm thick).</p> <p>Protecta FR Acrylic sealing pipe perimeter to wall on both faces (size 10 mm wide × 25 mm deep) backed with 25 mm deep stone mineral wool (33 kg/m³ density).</p>	None.	-/90/90
G – PE pipe with an outer diameter of Ø 160 mm and a pipe wall thickness of 9.5 mm	Ø 180 mm	<p>Pipe capping: U/C</p> <p>Protecta FR Collar 160 mm on both faces, fixed to the wall with 80 mm long wood screws (size 60 mm deep × 15 mm thick).</p> <p>Protecta FR Acrylic sealing pipe perimeter to wall on both faces (size 10 mm wide × 25 mm deep) backed with 25 mm deep stone mineral wool (33 kg/m³ density).</p>	None.	-/90/90
J – PP pipe with an outer diameter of Ø 160 mm and a pipe wall thickness of 4.9 mm	Ø 180 mm	<p>Pipe capping: U/C</p> <p>Protecta FR Collar 160 mm on both faces, fixed to the wall with 80 mm long wood</p>	None.	-/90/90

Specimen	Aperture	Seal description	Service insulation	FRL
		screws (size 60 mm deep × 15 mm thick). Protecta FR Acrylic sealing pipe perimeter to wall on both faces (size 10 mm wide × 25 mm deep) backed with 25 mm deep stone mineral wool (33 kg/m ³ density).		

B.15 Test report – WF19723

Table 110 Information about test report WF 19723

Item	Information about test report
Report sponsor	Polyseam Ltd, St Andrews Road, Huddersfield, West Yorkshire, HD1, 6SB, UK.
Test laboratory	Warringtonfire NV, Ottergemsesteenweg-Zuid 711, B-9000 Gent, Belgie.
Test date	The fire resistance test was completed on 25 June 2019.
Test standards	The test was done in accordance with BS EN 1366-3:2009.
Variation to test standards	None
General description of tested specimen	The supporting construction comprised of a cross laminated timber floor M Crosslam 150 5s NSI DL. The material was Spruce (Picea abies) and the slab dimensions were 1320 mm × 3300 mm. The slab thickness is 150 mm. The density is 480 kg/m ³ . The services referenced in this assessment report are referenced in Table 111.
Instrumentation	The test report states that the instrumentation was in accordance with BS EN 1366-3:2009.

The test specimen achieved the following results – see Table 111.

Table 111 Results summary for this test report

Specimen	Aperture	Seal description	Service insulation	FRL
G – PP pipe with an outer diameter of Ø 160 mm and a pipe wall thickness of 14.6 mm	Ø 180 mm	Pipe capping: U/C FR Collar 160 mm on exposed faces (size 60 mm deep × 15 mm thick). FR Acrylic on both faces (25 mm thick). Stone mineral wool 25 mm thick.	None.	-/90/90
O – PVC pipe with an outer diameter of Ø 110 mm and a pipe wall thickness of 2.7 mm	Ø 127 mm	Pipe capping: U/C FR Collar 110 mm on exposed faces (size 50 mm deep × 9 mm thick). FR Acrylic on both faces (25 mm thick). Stone mineral wool 25 mm thick.	None.	-/120/120
P – PP pipe with an outer diameter of Ø 50 mm and a pipe wall thickness of 2.9 mm	Ø 67 mm	Pipe capping: U/C FR Collar 50 mm on exposed faces (size 30 mm deep × 3 mm thick). FR Acrylic on both faces (25 mm thick). Stone mineral wool 25 mm thick.	None.	-/120/120

B.17 Test report – WF 392646

Table 112 Information about test report WF 392646

Item	Information about test report
Report sponsor	Polyseam Ltd, St Andrews Road, Huddersfield, West Yorkshire, HD1, 6SB, UK.
Test laboratory	Warringtonfire, Chiltern House, Stocking Lane, High Wycombe, HP14, 4ND, UK.
Test date	The fire resistance test was completed on 29 November 2017.
Test standards	The test was done in accordance with BS EN 1363-1:2012 and BS EN 1366-3:2009.
Variation to test standards	None
General description of tested specimen	<p>The supporting construction comprised of a 3000 mm wide × 3000 mm high steel stud / plasterboard clad partition.</p> <p>The partition framing consisted of 50 mm wide C-section studs at 600 mm centres with 50 mm thick 33 kg/m³ density mineral wool insulation friction fitted between the studs, and clad on both faces with 2 layers of 12.5 mm thick Type F plasterboard.</p> <p>The services referenced in this assessment report are referenced in Table 113. All pipes and cables measured 1200 mm long with a minimum of 500 mm protruding from the exposed face.</p>
Instrumentation	The test report states that the instrumentation was in accordance with BS EN 1363-1:2012 and BS EN 1366-3:2009.

The test specimen achieved the following results – see Table 113.

Table 113 Results summary for this test report

Specimen	Aperture	Seal description	Service insulation	FRL
A – Rehua Raupiano Plus PP-MD pipe with an outer diameter of Ø 50 mm and a pipe wall thickness of 3.9 mm	Ø 164 mm	Pipe capping: U/U Protecta FR Collar 160 mm fitted on both faces (size 60 mm deep × 15 mm wide). Protecta FR Acrylic sealing pipe to plasterboard on both faces (2 mm annular).	None.	-/120/120
E – Polo-Kal NG Poloplast PP-MV pipe with an outer diameter of Ø 160 mm and a pipe wall thickness of 4.9 mm	Ø 164 mm	Pipe capping: U/U Protecta FR Collar 160 mm fitted on both faces (size 60 mm deep × 15 mm wide). Protecta FR Acrylic sealing pipe to plasterboard on both faces (2 mm annular).	None.	-/120/120
F – Rehua Raupiano Plus PP-DD pipe with an outer diameter of Ø 125 mm and a pipe wall thickness of 3.1 mm	Ø 129 mm	Pipe capping: U/U Protecta FR Collar 125 mm fitted on both faces (size 60 mm deep × 9 mm wide). Protecta FR Acrylic sealing pipe to plasterboard on both faces (2 mm annular).	None.	-/120/120
G – Rehua Raupiano Plus PP-DD pipe with an outer diameter of Ø 50 mm and a pipe wall thickness of 1.8 mm	Ø 54 mm	Pipe capping: U/U Protecta FR Collar 55 mm fitted on both faces (size 50 mm deep × 3.2 mm wide).	None.	-/120/90

Specimen	Aperture	Seal description	Service insulation	FRL
		Protecta FR Acrylic sealing pipe to plasterboard on both faces (2 mm annular).		
K – Polo-Kal NG Poloplast PP-MV pipe with an outer diameter of Ø 125 mm and a pipe wall thickness of 3.9 mm	Ø 129 mm	Pipe capping: U/U Protecta FR Collar 125 mm fitted on both faces (size 60 mm deep × 9 mm wide). Protecta FR Acrylic sealing pipe to plasterboard on both faces (2 mm annular).	None.	-/120/-
L – Polo-Kal NG Poloplast PP-MV pipe with an outer diameter of Ø 50 mm and a pipe wall thickness of 2.0 mm	Ø 54 mm	Pipe capping: U/U Protecta FR Collar 55 mm fitted on both faces (size 50 mm deep × 3.2 mm wide). Protecta FR Acrylic sealing pipe to plasterboard on both faces (2 mm annular).	None.	-/120/120
M – Aquatherm Green SDR9 MF PP-RP pipe with an outer diameter of Ø 50 mm and a pipe wall thickness of 5.6 mm	Ø 54 mm	Pipe capping: C/C Protecta FR Collar 55 mm fitted on both faces (size 50 mm deep × 3.2 mm wide). Protecta FR Acrylic sealing pipe to plasterboard on both faces (2 mm annular).	None.	-/120/120
N – Rehua Raupiano Plus PP-DD pipe with an outer diameter of Ø 110 mm and a pipe wall thickness of 2.7 mm	Ø 114 mm	Pipe capping: U/U Protecta FR Collar 110 mm fitted on both faces (size 50 mm deep × 6 mm wide). Protecta FR Acrylic sealing pipe to plasterboard on both faces (2 mm annular).	None.	-/120/60
O – Aquatherm Green SDR9 MF PP-RP pipe with an outer diameter of Ø 110 mm and a pipe wall thickness of 12.3 mm	Ø 114 mm	Pipe capping: C/C Protecta FR Collar 110 mm fitted on both faces (size 50 mm deep × 6 mm wide). Protecta FR Acrylic sealing pipe to plasterboard on both faces (2 mm annular).	None.	-/120/60
R – Wavin SiTech + PP-M B pipe with an outer diameter of Ø 110 mm and a pipe wall thickness of 3.4 mm	Ø 114 mm	Pipe capping: U/U Protecta FR Collar 110 mm fitted on both faces (size 50 mm deep × 6 mm wide). Protecta FR Acrylic sealing pipe to plasterboard on both faces (2 mm annular).	None.	-/120/60
S – Polo-Kal NG Poloplast PP-MV pipe with an outer diameter of Ø 110 mm and a pipe wall thickness of 3.4 mm	Ø 114 mm	Pipe capping: U/U Protecta FR Collar 110 mm fitted on both faces (size 50 mm deep × 6 mm wide).	None.	-/120/90

Specimen	Aperture	Seal description	Service insulation	FRL
		Protecta FR Acrylic sealing pipe to plasterboard on both faces (2 mm annular).		
T – Wavin SiTech + PP-M B pipe with an outer diameter of Ø 50 mm and a pipe wall thickness of 1.8 mm	Ø 54 mm	Pipe capping: U/U Protecta FR Collar 55 mm fitted on both faces (size 50 mm deep × 3.2 mm wide). Protecta FR Acrylic sealing pipe to plasterboard on both faces (2 mm annular).	None.	-/120/120
U – Aquatherm Green SDR9 MF PP-RP pipe with an outer diameter of Ø 32 mm and a pipe wall thickness of 3.0 mm	Ø 36 mm	Pipe capping: C/C Protecta FR Collar 32 mm fitted on both faces (size 30 mm deep × 3 mm wide). Protecta FR Acrylic sealing pipe to plasterboard on both faces (2 mm annular).	None.	-/120/120

B.18 Test report – WF 395179

Table 114 Information about test report WF 395179

Item	Information about test report
Report sponsor	Polyseam Ltd, St Andrews Road, Huddersfield, West Yorkshire, HD1, 6SB, UK.
Test laboratory	Warringtonfire, Chiltern House, Stocking Lane, High Wycombe, HP14, 4ND, UK.
Test date	The fire resistance test was completed on 6 February 2018.
Test standards	The test was done in accordance with BS EN 1363-1:2012 and BS EN 1366-3:2009.
Variation to test standards	None
General description of tested specimen	<p>The supporting construction comprised of a 3000 mm wide × 3000 mm high steel stud / plasterboard clad partition.</p> <p>The partition framing consisted of 50 mm wide C-section studs at 600 mm centres with 50 mm thick 33 kg/m³ density mineral wool insulation friction fitted between the studs, and clad on both faces with 2 layers of 12.5 mm thick Type F plasterboard.</p> <p>The services referenced in this assessment report are referenced in Table 115. All pipes and cables measured 1200 mm long with a minimum of 500 mm protruding from the exposed face.</p>
Instrumentation	The test report states that the instrumentation was in accordance with BS EN 1363-1:2012 and BS EN 1366-3:2009.

The test specimen achieved the following results – see Table 115.

Table 115 Results summary for this test report

Specimen	Aperture	Seal description	Service insulation	FRL
K – Gerberit Silent PP pipe with an outer diameter of Ø 110 mm and a pipe wall thickness of 3.4 mm	Ø 114 mm	<p>Pipe capping: U/U</p> <p>Protecta FR Collar 110 mm fitted on both faces (size 50 mm deep × 6 mm wide).</p> <p>Protecta FR Acrylic sealing pipe to plasterboard on both faces (2 mm × 2 mm nominal bead).</p>	None.	-/120/60
L – Gerberit Silent PP pipe with an outer diameter of Ø 50 mm and a pipe wall thickness of 1.8 mm	Ø 54 mm	<p>Pipe capping: U/U</p> <p>Protecta FR Collar 50 mm fitted on both faces (size 50 mm deep × 3 mm wide).</p> <p>Protecta FR Acrylic sealing pipe to plasterboard on both faces (2 mm × 2 mm nominal bead).</p>	None.	-/120/120
N – Poloplast Polo-Kal NG pipe with an outer diameter of Ø 125 mm and a pipe wall thickness of 3.9 mm	Ø 145 mm	<p>Pipe capping: U/C</p> <p>Protecta FR Collar 125 mm fitted on both faces (size 125 mm deep × 9 mm wide).</p> <p>Protecta FR Acrylic fitted on both faces (10 mm wide × 25 mm deep).</p>	None.	-/120/120

B.19 Test report – WF 398928

Table 116 Information about test report WF 398928

Item	Information about test report
Report sponsor	Polyseam Ltd, St Andrews Road, Huddersfield, West Yorkshire, HD1, 6SB, UK.
Test laboratory	Warringtonfire, Chiltern House, Stocking Lane, High Wycombe, HP14, 4ND, UK.
Test date	The fire resistance test was completed on 6 August 2018.
Test standards	The test was done in accordance with BS EN 1363-1:2012 and BS EN 1366-3:2009.
Variation to test standards	None
General description of tested specimen	<p>The supporting construction comprised of a 3000 mm wide × 3000 mm high steel stud / plasterboard clad partition.</p> <p>The partition framing consisted of 50 mm wide C-section studs at 600 mm centres with 50 mm thick 35 kg/m³ density mineral wool insulation friction fitted between the studs, and clad on both faces with 2 layers of 12.5 mm thick Type F plasterboard.</p> <p>The services referenced in this assessment report are referenced in Table 117. All pipes and cables measured 1200 mm long with a minimum of 500 mm protruding from the exposed face.</p>
Instrumentation	The test report states that the instrumentation was in accordance with BS EN 1363-1:2012 and BS EN 1366-3:2009.

The test specimen achieved the following results – see Table 117.

Table 117 Results summary for this test report

Specimen	Aperture	Seal description	Service insulation	FRL
A – Copper pipe with an outer diameter of Ø 54 mm and a pipe wall thickness of 1.2 mm	Ø 94 mm	<p>Pipe capping: C/C</p> <p>Protecta FR Collar 110 mm fitted on both faces (size 50 mm deep × 6 mm wide).</p> <p>Protecta FR Acrylic sealing pipe to plasterboard on both faces (1 mm nominal bead).</p>	19 mm thick Kaiflex ST foam insulation continuous sustained.	-/120/90
C – Copper pipe with an outer diameter of Ø 54 mm and a pipe wall thickness of 1.2 mm	Ø 108 mm	<p>Pipe capping: C/C</p> <p>Protecta FR Collar 110 mm fitted on both faces (size 50 mm deep × 6 mm wide).</p> <p>Protecta FR Acrylic (2 mm nominal seal).</p>	25 mm thick (Supaphen Phenolic Foam) insulation continuous sustained.	-/120/60
E – Copper pipe with an outer diameter of Ø 54 mm and a pipe wall thickness of 1.2 mm	Ø 96 mm	<p>Pipe capping: C/C</p> <p>Protecta FR Collar 110 mm fitted on both faces (size 50 mm deep × 6 mm wide).</p> <p>Protecta FR Acrylic (1 mm nominal seal).</p>	20 mm thick Kaifoam PE insulation continuous sustained.	-/120/90
F – 1No. Type C1, 1No. Type C2, 1No. Type C3 and 1No. Type E cable bundle with a diameter of Ø 95 mm.	Ø 95 mm	<p>Protecta FR Collar 110 mm fitted on both faces (size 50 mm deep × 6 mm thick).</p> <p>Protecta FR Acrylic sealing cables to plasterboard and gaps between cables</p>	None.	-/120/60

Specimen	Aperture	Seal description	Service insulation	FRL
		(Continuous bead sealed between cables nominally 10 mm deep).		
G – 99No. Type F cable bundle with a diameter of Ø 160 mm.	Ø 160 mm	Protecta FR Collar 160 mm fitted on both faces (size 60 mm deep × 15 mm thick). Protecta FR Acrylic sealing cables to plasterboard (Continuous bead).	None.	-/120/90
H – 12No. Type F cable bundle with a diameter of Ø 55 mm.	Ø 55 mm	Protecta FR Collar 55 mm fitted on both faces (size 30 mm deep × 3.2 mm thick). Protecta FR Acrylic sealing cables to plasterboard (Continuous bead).	None.	-/120/90
I – 1No. Type D1, 1No. Type D2 and 1No. Type D3 cable bundle with a diameter of Ø 130 mm.	Ø 130 mm	Protecta FR Collar 125 mm fitted on both faces (size 60 mm deep × 9 mm thick). Protecta FR Acrylic sealing cables to plasterboard and gaps between cables (Continuous bead 25 mm deep filling around gaps and edges).	None.	-/120/90
K – blank penetration	Ø 55 mm	Protecta FR Collar 55 mm fitted on both faces (size 30 mm deep × 3.2 mm thick). 25 mm wide stone mineral wool (33 kg/m ³ density) fitted in each aperture.	None.	-/120/60
M – Blue Power Multilayer pipe with an outer diameter of Ø 50 mm and a pipe wall thickness of 1.8 mm	Ø 52 mm	Protecta FR Collar 55 mm fitted on both faces (size 50 mm deep × 3.2 mm thick). Protecta FR Acrylic sealing cables to plasterboard (Continuous bead sealed flush).	None.	-/120/90
O – 1No. Type A1, 1No. Type A2, 1No. Type A3 and 1No. Type B cable bundle with a diameter of Ø 32 mm.	Ø 32 mm	Protecta FR Collar 55 mm fitted on both faces (size 30 mm deep × 3.2 mm thick). Protecta FR Acrylic sealing cables to plasterboard (Continuous bead nominal 5 mm deep).	None.	-/120/60
P – 45No. Type F cable bundle with a diameter of Ø 110 mm.	Ø 110 mm	Protecta FR Collar 110 mm fitted on both faces (size 30 mm deep × 6 mm thick). Protecta FR Acrylic sealing cables to plasterboard (Continuous bead sealed flush).	None.	-/120/60

Specimen	Aperture	Seal description	Service insulation	FRL
Q – 3No. pipes in bundle. Uponor inner pipe / Uponor Aqua outer pipe – pipe in pipe system with a diameter of Ø 55 mm and a pipe wall thickness of 0.6 mm (outer) and 2.5 mm (inner).	Ø 25 mm (outer) Ø 15 mm (inner)	Protecta FR Collar 55 mm fitted on both faces (size 30 mm deep × 3.2 mm thick). Protecta FR Acrylic sealing pipes to plasterboard (Continuous bead 10 mm deep between pipes).	None.	-/120/90
R – Blue Power Multilayer pipe with an outer diameter of Ø 110 mm and a pipe wall thickness of 3.4 mm	Ø 114 mm	Pipe capping: C/U Protecta FR Collar 110 mm fitted on both faces (size 50 mm deep × 6 mm thick). Protecta FR Acrylic sealing pipe to plasterboard (continuous bead sealed flush nominal 2 mm × 2 mm).	None.	-/120/60
S – Blank penetration	Ø 112 mm	Protecta FR Collar 110 mm fitted on both faces (size 30 mm deep × 6 mm thick). 25 mm wide stone mineral wool (33 kg/m ³ density) fitted in each aperture.	None.	-/120/60

B.20 Test report – WF 398517

Table 118 Information about test report WF 398517

Item	Information about test report
Report sponsor	Polyseam Ltd, St Andrews Road, Huddersfield, West Yorkshire, HD1, 6SB, UK.
Test laboratory	Warringtonfire, Chiltern House, Stocking Lane, High Wycombe, HP14, 4ND, UK.
Test date	The fire resistance test was completed on 19 April 2018.
Test standards	The test was done in accordance with BS EN 1363-1:2012 and BS EN 1366-3:2009.
Variation to test standards	None
General description of tested specimen	<p>The supporting construction comprised of a 3000 mm wide × 3000 mm high steel stud / plasterboard clad partition.</p> <p>The partition framing consisted of 50 mm wide C-section studs at 600 mm centres with 50 mm thick 33 kg/m³ density mineral wool insulation friction fitted between the studs, and clad on both faces with 2 layers of 12.5 mm thick Type F plasterboard.</p> <p>The services referenced in this assessment report are referenced in Table 119. All pipes and cables measured 1200 mm long with a minimum of 500 mm protruding from the exposed face.</p>
Instrumentation	The test report states that the instrumentation was in accordance with BS EN 1363-1:2012 and BS EN 1366-3:2009.

The test specimen achieved the following results – see Table 119.

Table 119 Results summary for this test report

Specimen	Aperture	Seal description	Service insulation	FRL
I – Blue Power Multilayer pipe with an outer diameter of Ø 160 mm and a pipe wall thickness of 4.9 mm	Ø 164 mm	<p>Pipe capping: C/U</p> <p>Protecta FR Collar 160 mm fitted on both faces (size 60 mm deep × 15 mm thick).</p> <p>Protecta FR Acrylic fitted on both faces (2 mm wide × 2 mm deep).</p>	None.	-/90/90
L – PE pipe with an outer diameter of Ø 110 mm and a pipe wall thickness of 10 mm	Ø 110 mm	<p>Pipe capping: C/C</p> <p>Protecta FR Collar 110 mm fitted on both faces (size 50 mm deep × 6 mm thick).</p> <p>Pipe friction fitted to board and sealed with Protecta FR Acrylic.</p>	None.	-/90/60

B.21 Test report – WF 384982

Table 120 Information about test report WF 384982

Item	Information about test report
Report sponsor	Polyseam Ltd, St Andrews Road, Huddersfield, West Yorkshire, HD1, 6SB, UK.
Test laboratory	Warringtonfire, Chiltern House, Stocking Lane, High Wycombe, HP14, 4ND, UK.
Test date	The fire resistance test was completed on 29 June 2017.
Test standards	The test was done in accordance with BS EN 1363-1:2012 and BS EN 1366-3:2009.
Variation to test standards	None
General description of tested specimen	<p>The supporting construction comprised of a 3000 mm wide × 3000 mm high steel stud / plasterboard clad partition. The partition framing consisted of 50 mm wide C-section studs at 600 mm centres with 50 mm thick 33 kg/m³ density mineral wool insulation friction fitted between the studs, and clad on both faces with 2 layers of 12.5 mm thick Type F plasterboard.</p> <p>The services referenced in this assessment report are referenced in Table 121. All pipes and cables measured 1200 mm long with a minimum of 500 mm protruding from the exposed face.</p>
Instrumentation	The test report states that the instrumentation was in accordance with BS EN 1363-1:2012 and BS EN 1366-3:2009.

The test specimen achieved the following results – see Table 121.

Table 121 Results summary for this test report

Specimen	Aperture	Seal description	Service insulation	FRL
C2 – PE pipe with an outer diameter of Ø 110 mm and a pipe wall thickness of 3.4 mm	Ø 110 mm	Pipe capping: U/C Protecta FR Collar+ on each face (size 50 mm wide × 6 mm thick).	None.	-/120/60
C3 – PVC pipe with an outer diameter of Ø 40 mm and a pipe wall thickness of 1.9 mm	Ø 40 mm	Pipe capping: U/C Protecta FR Collar on each face (size 30 mm wide × 2.4 mm thick).	None.	-/120/60
D1 – PE pipe with an outer diameter of Ø 50 mm and a pipe wall thickness of 3.0 mm	Ø 50 mm	Pipe capping: U/C Protecta FR Collar+ on each face (size 50 mm wide × 3.0 mm thick).	None.	-/120/90
D2 – PE pipe with an outer diameter of Ø 50 mm and a pipe wall thickness of 4.6 mm	Ø 50 mm	Pipe capping: U/C Protecta FR Collar+ on each face (size 50 mm wide × 3.0 mm thick).	None.	-/120/60
D3 – PVC pipe with an outer diameter of Ø 50 mm and a pipe wall thickness of 3.7 mm	Ø 50 mm	Pipe capping: U/C Protecta FR Collar+ on each face (size 50 mm wide × 3.0 mm thick).	None.	-/120/120
I – PE pipe with an outer diameter of Ø 50 mm and a pipe wall thickness of 4.6 mm	Ø 54 mm	Pipe capping: U/U Protecta FR Collar+ on both faces (size 50 mm deep × 3 mm thick).	None.	-/120/90

Specimen	Aperture	Seal description	Service insulation	FRL
		Protecta FR Acrylic fitted on both faces (3 mm deep continuous bead).		
J – PE pipe with an outer diameter of Ø 50 mm and a pipe wall thickness of 3.0 mm	Ø 54 mm	Pipe capping: U/U Protecta FR Collar+ on both faces (size 50 mm deep × 3 mm thick). Protecta FR Acrylic fitted on both faces (3 mm deep continuous bead).	None.	-/120/90

B.22 Test report – WF 376483

Table 122 Information about test report WF 376483

Item	Information about test report
Report sponsor	Polyseam Ltd, St Andrews Road, Huddersfield, West Yorkshire, HD1, 6SB, UK.
Test laboratory	Warringtonfire, Chiltern House, Stocking Lane, High Wycombe, HP14, 4ND, UK.
Test date	The fire resistance test was completed on 29 November 2016.
Test standards	The test was done in accordance with BS EN 1363-1:2012, BS EN 1366-3:2009 and BS EN 1366-4:2006 +A1:2010.
Variation to test standards	None
General description of tested specimen	<p>The supporting construction comprised of a 3000 mm wide × 3000 mm high steel stud / plasterboard clad partition. The partition framing consisted of 50 mm wide C-section studs at 600 mm centres with 50 mm thick 33 kg/m³ density mineral wool insulation friction fitted between the studs, and clad on both faces with 2 layers of 12.5 mm thick Type F plasterboard.</p> <p>The services referenced in this assessment report are referenced in Table 123. All pipes and cables measured 1200 mm long with a minimum of 500 mm protruding from the exposed face.</p>
Instrumentation	The test report states that the instrumentation was in accordance with BS EN 1363-1:2012 and BS EN 1366-3:2009.

The test specimen achieved the following results – see Table 123.

Table 123 Results summary for this test report

Specimen	Aperture	Seal description	Service insulation	FRL
G – PVC pipe with an outer diameter of Ø 110 mm and a pipe wall thickness of 2.7 mm	Ø 110 mm	Pipe capping: U/C Protecta FR Collar+ on both faces (size 30 mm wide × 6 mm thick).	None.	-/90/60
H – PVC pipe with an outer diameter of Ø 110 mm and a pipe wall thickness of 6.6 mm	Ø 110 mm	Pipe capping: U/C Protecta FR Collar on both faces (size 30 mm wide × 6 mm thick).	None.	-/90/60

B.23 Test report – WF 394232

Table 124 Information about test report WF 394232

Item	Information about test report
Report sponsor	Polyseam Ltd, St Andrews Road, Huddersfield, West Yorkshire, HD1, 6SB, UK.
Test laboratory	Warringtonfire, Chiltern House, Stocking Lane, High Wycombe, HP14, 4ND, UK.
Test date	The fire resistance test was completed on 11 January 2018.
Test standards	The test was done in accordance with BS EN 1363-1:2012 and BS EN 1366-3:2009.
Variation to test standards	None
General description of tested specimen	The separating element is a 150 mm thick aerated autoclaved concrete (AAC) blockwork and reinforced lintel wall built in a refractory lined steel restraint frame in front of a 3 m × 3 m furnace aperture. The services referenced in this assessment report are referenced in Table 125. All pipes and cables measured 1200 mm long with a minimum of 500 mm protruding from the exposed face.
Instrumentation	The test report states that the instrumentation was in accordance with BS EN 1363-1:2012 and BS EN 1366-3:2009.

The test specimen achieved the following results – see Table 125.

Table 125 Results summary for this test report

Specimen	Aperture	Seal description	Service insulation	FRL
E – PP pipe with an outer diameter of Ø 110 mm and a pipe wall thickness of 6.3 mm	Ø 114 mm	Pipe capping: U/U Protecta FR Collar 110 mm fitted on both faces (size 50 mm wide × 6 mm deep). Protecta FR Acrylic sealing pipe to blockwork on both faces (2 mm × 2 mm nominal bead)	None.	-/240/90

B.24 Test report – WF 372808

Table 126 Information about test report WF 372808

Item	Information about test report
Report sponsor	Polyseam Ltd, St Andrews Road, Huddersfield, West Yorkshire, HD1, 6SB, UK.
Test laboratory	Warringtonfire, Chiltern House, Stocking Lane, High Wycombe, HP14, 4ND, UK.
Test date	The fire resistance test was completed on 12 October 2016.
Test standards	The test was done in accordance with BS EN 1363-1:2012 and BS EN 1366-3:2009.
Variation to test standards	None
General description of tested specimen	The supporting construction comprised 150 mm thick reinforced AAC blockwork / lintel floor slab. The services referenced in this assessment report are referenced in Table 127. All pipes and cables measured 1200 mm long with a minimum of 500 mm protruding from the exposed face.
Instrumentation	The test report states that the instrumentation was in accordance with BS EN 1363-1:2012 and BS EN 1366-3:2009.

The test specimen achieved the following results – see Table 127.

Table 127 Results summary for this test report

Specimen	Aperture	Seal description	Service insulation	FRL
P – PVC pipe with an outer diameter of Ø 110 mm and a pipe wall thickness of 3.2 mm	Ø 120 mm	Pipe capping: U/C Protecta 110 FR Collar+ fitted on the unexposed face, fixed with 4No. 50 mm long Spax masonry fixings (size 50 mm wide × 6 mm thick). Protecta FR Acrylic sealing collar to pipe and collar to floor (2 mm × 2 mm nominal bead)	None	-/120/120

B.25 Test report – WF 382336

Table 128 Information about test report WF 382336

Item	Information about test report
Report sponsor	Polyseam Ltd, St Andrews Road, Huddersfield, West Yorkshire, HD1, 6SB, UK.
Test laboratory	Warringtonfire, Chiltern House, Stocking Lane, High Wycombe, HP14, 4ND, UK.
Test date	The fire resistance test was completed on 15 June 2017.
Test standards	The test was done in accordance with BS EN 1363-1:2012 and BS EN 1366-3:2009.
Variation to test standards	None
General description of tested specimen	The supporting construction comprised 150 mm thick reinforced AAC lintel floor slab. The services referenced in this assessment report are referenced in Table 129. All pipes and cables measured 1200 mm long with a minimum of 500 mm protruding from the exposed face.
Instrumentation	The test report states that the instrumentation was in accordance with BS EN 1363-1:2012 and BS EN 1366-3:2009.

The test specimen achieved the following results – see Table 129.

Table 129 Results summary for this test report

Specimen	Aperture	Seal description	Service insulation	FRL
K – PVC pipe with an outer diameter of Ø 110 mm and a pipe wall thickness of 2.7 mm	Ø 127 mm	Pipe capping: C/C 50 mm Protecta FR Collar+ fitted on the exposed face (size 50 mm wide × 3 mm thick). Protecta FR Acrylic (8.5 mm wide × 10 mm deep). Rock mineral wool backing (8.5 mm wide × 20 mm deep).	None.	-/120/120

B.26 Test report – WF 394948

Table 130 Information about test report WF 394948

Item	Information about test report
Report sponsor	Polyseam Ltd, St Andrews Road, Huddersfield, West Yorkshire, HD1, 6SB, UK.
Test laboratory	Warringtonfire, Chiltern House, Stocking Lane, High Wycombe, HP14, 4ND, UK.
Test date	The fire resistance test was completed on 30 January 2018.
Test standards	The test was done in accordance with BS EN 1363-1:2012 and BS EN 1366-3:2009.
Variation to test standards	None
General description of tested specimen	The supporting construction comprised 150 mm thick reinforced AAC floor slab. The services referenced in this assessment report are referenced in Table 131. All pipes and cables measured 1200 mm long with a minimum of 500 mm protruding from the exposed face.
Instrumentation	The test report states that the instrumentation was in accordance with BS EN 1363-1:2012 and BS EN 1366-3:2009.

The test specimen achieved the following results – see Table 131.

Table 131 Results summary for this test report

Specimen	Aperture	Seal description	Service insulation	FRL
D – Palo-Kal NG pipe with an outer diameter of Ø 160 mm and a pipe wall thickness of 4.9 mm	Ø 164 mm	Pipe capping: C/U Protecta FR Collar 160 mm fitted on the exposed face, fixed with 4No. 60 mm long masonry screws (size 60 mm high × 15 mm thick). Protecta FR Acrylic sealing between pipe and floor on the exposed face (Continuous bead).	None.	-/240/-
E – Gerberit Silent PP pipe with an outer diameter of Ø 50 mm and a pipe wall thickness of 1.8 mm	Ø 54 mm	Pipe capping: U/U Protecta FR Collar 55 mm fitted on the exposed face, fixed with 4No. 50 mm long masonry screws (size 50 mm high × 3.2 mm thick). Protecta FR Acrylic sealing between pipe and floor on the exposed face (Continuous bead).	None.	-/240/240
F – Palo-Kal NG pipe with an outer diameter of Ø 50 mm and a pipe wall thickness of 2.0 mm	Ø 54 mm	Pipe capping: U/U Protecta FR Collar 55 mm fitted on the exposed face, fixed with 4No. 50 mm long masonry screws (size 50 mm high × 3.2 mm thick). Protecta FR Acrylic sealing between pipe and floor on the exposed face (Continuous bead).	None.	-/240/240
G – Gerberit Silent PP pipe with an outer diameter of Ø 110 mm	Ø 114 mm	Pipe capping: C/U	None.	-/180/180

Specimen	Aperture	Seal description	Service insulation	FRL
and a pipe wall thickness of 3.4 mm		Protecta FR Collar 110 mm fitted on the exposed face, fixed with 4No. 50 mm long masonry screws (size 50 mm high × 6.0 mm thick). Protecta FR Acrylic sealing between pipe and floor on the exposed face (Continuous bead).		
H – Wavin Sitech pipe with an outer diameter of Ø 50 mm and a pipe wall thickness of 1.8 mm	Ø 54 mm	Pipe capping: C/U Protecta FR Collar 55 mm fitted on the exposed face, fixed with 4No. 50 mm long masonry screws (size 50 mm high × 3.2 mm thick). Protecta FR Acrylic sealing between pipe and floor on the exposed face (Continuous bead).	None.	-/240/240

B.27 Test report – WF 394021

Table 132 Information about test report WF 394021

Item	Information about test report
Report sponsor	Polyseam Ltd, St Andrews Road, Huddersfield, West Yorkshire, HD1, 6SB, UK.
Test laboratory	Warringtonfire, Chiltern House, Stocking Lane, High Wycombe, HP14, 4ND, UK.
Test date	The fire resistance test was completed on 8 January 2018.
Test standards	The test was done in accordance with BS EN 1363-1:2012 and BS EN 1366-3:2009.
Variation to test standards	None
General description of tested specimen	The supporting construction comprised 150 mm thick reinforced AAC blockwork / lintel floor slab. The services referenced in this assessment report are referenced in Table 133. All pipes and cables measured 1200 mm long with a minimum of 500 mm protruding from the exposed face.
Instrumentation	The test report states that the instrumentation was in accordance with BS EN 1363-1:2012 and BS EN 1366-3:2009.

The test specimen achieved the following results – see Table 133.

Table 133 Results summary for this test report

Specimen	Aperture	Seal description	Service insulation	FRL
D – Wavin Sitech PP-M pipe with an outer diameter of Ø 110 mm and a pipe wall thickness of 3.4 mm	Ø 112 mm	Pipe capping: C/U Protecta FR Collar fitted on the exposed face, fixed with 4No. 50 mm long masonry screws (size 50 mm high × 3.2 mm thick). FR Acrylic bead between pipe and floor.	None.	-/180/180
E – Poloplast Polo-Kal Ng PP/PP-MV pipe with an outer diameter of Ø 110 mm and a pipe wall thickness of 3.4 mm	Ø 112 mm	Pipe capping: C/U Protecta FR Collar fitted on the exposed face, fixed with 4No. 50 mm long masonry fixings (size 50 mm wide × 6 mm thick). FR Acrylic bead between pipe and floor.	None.	-/240/240

B.28 Test report – WF 397678

Table 134 Information about test report WF 397678

Item	Information about test report
Report sponsor	Polyseam Ltd, St Andrews Road, Huddersfield, West Yorkshire, HD1, 6SB, UK.
Test laboratory	Warringtonfire, Chiltern House, Stocking Lane, High Wycombe, HP14, 4ND, UK.
Test date	The fire resistance test was completed on 22 March 2018.
Test standards	The test was done in accordance with BS EN 1363-1:2012 and BS EN 1366-3:2009.
Variation to test standards	None
General description of tested specimen	The supporting construction comprised 150 mm thick reinforced AAC lintel floor slab. The services referenced in this assessment report are referenced in Table 135. All pipes and cables measured 1200 mm long with a minimum of 500 mm protruding from the exposed face.
Instrumentation	The test report states that the instrumentation was in accordance with BS EN 1363-1:2012 and BS EN 1366-3:2009.

The test specimen achieved the following results – see Table 135.

Table 135 Results summary for this test report

Specimen	Aperture	Seal description	Service insulation	FRL
A – Palo-Kal NG pipe with an outer diameter of Ø 160 mm and a pipe wall thickness of 4.9 mm	Ø 165 mm	Pipe capping: U/C Protecta FR Collar fitted on the exposed face, fixed with 4No. 40 mm long masonry screws (size 60 mm wide × 15 mm thick). Protecta FR Acrylic sealing pipe to floor on the unexposed face pipe (2 mm bead).	None.	-/240/240
B – Palo-Kal NG pipe with an outer diameter of Ø 125 mm and a pipe wall thickness of 3.9 mm	Ø 129 mm	Pipe capping: U/C Protecta FR Collar 125 mm fitted on the exposed face, fixed with 4No. 40 mm long masonry screws (size 60 mm wide × 9 mm thick). Protecta FR Acrylic sealing pipe to floor on the unexposed face pipe (2 mm bead).	None.	-/240/240
C – Rehau Raupiano Plus pipe with an outer diameter of Ø 50 mm and a pipe wall thickness of 1.8 mm	Ø 54 mm	Pipe capping: U/U Protecta FR Collar 55 mm fitted on the exposed face, fixed with 4No. 40 mm long masonry screws (size 50 mm wide × 3.2 mm thick). Protecta FR Acrylic sealing pipe to floor on the unexposed face pipe (2 mm bead).	None.	-/240/240

B.29 Test report – WF 396820

Table 136 Information about test report WF 396820

Item	Information about test report
Report sponsor	Polyseam Ltd, St Andrews Road, Huddersfield, West Yorkshire, HD1, 6SB, UK.
Test laboratory	Warringtonfire, Chiltern House, Stocking Lane, High Wycombe, HP14, 4ND, UK.
Test date	The fire resistance test was completed on 28 February 2018.
Test standards	The test was done in accordance with BS EN 1363-1:2012 and BS EN 1366-3:2009.
Variation to test standards	None
General description of tested specimen	The supporting construction comprised 150 mm thick reinforced AAC lintel floor slab. The services referenced in this assessment report are referenced in Table 137. All pipes and cables measured 1200 mm long with a minimum of 500 mm protruding from the exposed face.
Instrumentation	The test report states that the instrumentation was in accordance with BS EN 1363-1:2012 and BS EN 1366-3:2009.

The test specimen achieved the following results – see Table 137.

Table 137 Results summary for this test report

Specimen	Aperture	Seal description	Service insulation	FRL
C – Rehau Raupiano Plus pipe with an outer diameter of Ø 160 mm and a pipe wall thickness of 3.9 mm	Ø 164 mm	Pipe capping: U/C Protecta FR Collar fitted on the exposed face, fixed with 4No. 60 mm long masonry screws (size 60 mm wide × 15 mm thick). Protecta FR Acrylic bead sealing pipe to floor on the unexposed face pipe.	None.	-/240/240

B.30 Test report – WF 397686

Table 138 Information about test report WF 397686

Item	Information about test report
Report sponsor	Polyseam Ltd, St Andrews Road, Huddersfield, West Yorkshire, HD1, 6SB, UK.
Test laboratory	Warringtonfire, Chiltern House, Stocking Lane, High Wycombe, HP14, 4ND, UK.
Test date	The fire resistance test was completed on 28 March 2018.
Test standards	The test was done in accordance with BS EN 1363-1:2012 and BS EN 1366-3:2009.
Variation to test standards	None
General description of tested specimen	The supporting construction comprised 150 mm thick reinforced AAC lintel floor slab. The services referenced in this assessment report are referenced in Table 139. All pipes and cables measured 1200 mm long with a minimum of 500 mm protruding from the exposed face.
Instrumentation	The test report states that the instrumentation was in accordance with BS EN 1363-1:2012 and BS EN 1366-3:2009.

The test specimen achieved the following results – see Table 139.

Table 139 Results summary for this test report

Specimen	Aperture	Seal description	Service insulation	FRL
C – Blank seal	Ø 57 mm	Protecta FR Collar 55 mm fitted on the exposed face, fixed with 4No. 40 mm long masonry screws (size 30 mm wide × 3.2 mm thick). 25 mm thick mineral wool (density 33 kg/m ³ flush to fire side of floor slab.	None.	-/240/60
D – PP pipe with an outer diameter of Ø 160 mm and a pipe wall thickness of 6.2 mm	Ø 164 mm	Pipe capping: U/U Protecta FR Collar 160 mm fitted on the exposed face, fixed with 4No. 40 mm long masonry screws (size 60 mm deep × 15 mm thick). Protecta FR Acrylic bead sealing the top of the collar and between the pipe and collar (2 mm bead).	None.	-/90/90

B.31 Test report – WF 380963

Table 140 Information about test report WF 380963

Item	Information about test report
Report sponsor	Polyseam Ltd, St Andrews Road, Huddersfield, West Yorkshire, HD1, 6SB, UK.
Test laboratory	Warringtonfire, Chiltern House, Stocking Lane, High Wycombe, HP14, 4ND, UK.
Test date	The fire resistance test was completed on 6 March 2017.
Test standards	The test was done in accordance with BS EN 1363-1:2012 and BS EN 1366-3:2009.
Variation to test standards	None
General description of tested specimen	The supporting construction comprised of a reinforced AAC lintel/block floor slab. The services referenced in this assessment report are referenced in Table 141. All pipes and cables measured 1200 mm long with a minimum of 500 mm protruding from the exposed face.
Instrumentation	The test report states that the instrumentation was in accordance with BS EN 1363-1:2012 and BS EN 1366-3:2009.

The test specimen achieved the following results – see Table 141.

Table 141 Results summary for this test report

Specimen	Aperture	Seal description	Service insulation	FRL
I – Cable F bundle with an outer diameter of Ø 100 mm and an individual cable diameter Ø 14 mm	Ø 127 mm	Protecta FR Collar+ fitted flush with exposed face (size 50 mm wide × 6 mm thick). Protecta FR Acrylic (8-9 mm wide × 10 mm deep). Rock mineral wool backing (8-9 mm wide × 20 mm deep).	None.	-/90/90

B.32 Test report – WF 390800

Table 142 Information about test report WF 390800

Item	Information about test report
Report sponsor	Polyseam Ltd, St Andrews Road, Huddersfield, West Yorkshire, HD1, 6SB, UK.
Test laboratory	Warringtonfire, Chiltern House, Stocking Lane, High Wycombe, HP14, 4ND, UK.
Test date	The fire resistance test was completed on 19 October 2017.
Test standards	The test was done in accordance with BS EN 1363-1:2012 and BS EN 1366-3:2009.
Variation to test standards	None
General description of tested specimen	The supporting construction comprised of a 150 mm reinforced AAC blockwork/lintel floor slab. The services referenced in this assessment report are referenced in Table 143. All pipes and cables measured 1200 mm long with a minimum of 500 mm protruding from the exposed face.
Instrumentation	The test report states that the instrumentation was in accordance with BS EN 1363-1:2012 and BS EN 1366-3:2009.

The test specimen achieved the following results – see Table 143.

Table 143 Results summary for this test report

Specimen	Aperture	Seal description	Service insulation	FRL
A – PP pipe with an outer diameter of Ø 160 mm and a pipe wall thickness of 14.7 mm	Ø 162 mm	Pipe capping: U/U Protecta FR Collar 160 mm fitted to the exposed face (size 60 mm wide × 15 mm thick). Protecta FR Acrylic sealing end of collar.	None.	-/60/60
C – Rehau Raupiano Plus PP-MD pipe with an outer diameter of Ø 160 mm and a pipe wall thickness of 3.9 mm	Ø 162 mm	Pipe capping: C/U Protecta FR Collar fitted on the exposed face (size 60 mm wide × 15 mm thick). FR Acrylic bead between pipe and floor.	None.	-/240/-
F – PVC pipe with an outer diameter of Ø 50 mm and a pipe wall thickness of 3.7 mm	Ø 52 mm	Pipe capping: U/C Protecta FR Collar 55 mm fitted on the unexposed face (size 50 mm wide × 3.2 mm thick). Protecta FR Acrylic sealing end of collar.	None.	-/240/240
G – PP pipe with an outer diameter of Ø 50 mm and a pipe wall thickness of 4.6 mm	Ø 52 mm	Pipe capping: U/C Protecta FR Collar 55 mm fitted on the unexposed face (size 50 mm wide × 3.2 mm thick). Protecta FR Acrylic sealing end of collar.	None.	-/240/180
H – PP pipe with an outer diameter of Ø 50 mm and a pipe wall thickness of 2.9 mm	Ø 52 mm	Pipe capping: U/C Protecta FR Collar 55 mm fitted on the unexposed face (size 50 mm wide × 3.2 mm thick).	None.	-/240/240

Specimen	Aperture	Seal description	Service insulation	FRL
		Protecta FR Acrylic sealing end of collar.		
I – PP pipe with an outer diameter of Ø 50 mm and a pipe wall thickness of 2.9 mm	Ø 52 mm	Pipe capping: U/U Protecta FR Collar 55 mm fitted on the exposed face (size 30 mm wide × 3.2 mm thick). FR Acrylic bead between pipe and floor.	None.	-/90/90
J – PP pipe with an outer diameter of Ø 50 mm and a pipe wall thickness of 2.9 mm	Ø 52 mm	Pipe capping: U/C Protecta FR Collar 55 mm fitted on the exposed face (size 30 mm wide × 3.2 mm thick). FR Acrylic bead between pipe and floor.	None.	-/240/240
K – PP pipe with an outer diameter of Ø 50 mm and a pipe wall thickness of 2.9 mm	Ø 52 mm	Pipe capping: U/U Protecta FR Collar 55 mm fitted on the exposed face (size 50 mm wide × 3.2 mm thick). FR Acrylic bead between pipe and floor.	None.	-/240/240
L – Aquatherm Green SDR9 MF PP-RP pipe with an outer diameter of Ø 50 mm and a pipe wall thickness of 5.6 mm	Ø 52 mm	Pipe capping: C/C Protecta FR Collar 55 mm fitted on the exposed face (size 50 mm wide × 3.2 mm thick). FR Acrylic bead between pipe and floor.	None.	-/240/240
M – Aquatherm Green SDR9 MF PP-RP pipe with an outer diameter of Ø 32 mm and a pipe wall thickness of 3.6 mm	Ø 32 mm	Pipe capping: C/C Protecta FR Collar 32 mm fitted on the exposed face (size 30 mm wide × 3.0 mm thick). FR Acrylic bead between pipe and floor.	None.	-/240/240
N – Rehau Raupaiaino Plus PP-MD pipe with an outer diameter of Ø 110 mm and a pipe wall thickness of 2.7 mm	Ø 112 mm	Pipe capping: C/U Protecta FR Collar 110 mm fitted on the exposed face (size 50 mm wide × 6.0 mm thick). FR Acrylic bead between pipe and floor.	None.	-/120/120
O – Aquatherm Green SDR9 MF PP-RP pipe with an outer diameter of Ø 110 mm and a pipe wall thickness of 12.3 mm	Ø 112 mm	Pipe capping: C/C Protecta FR Collar fitted on the exposed face (size 50 mm wide × 6.0 mm thick). FR Acrylic bead between pipe and floor.	None.	-/120/120
P – PVC pipe with an outer diameter of Ø 110 mm and a pipe wall thickness of 2.7 mm	Ø 112 mm	Pipe capping: C/U Protecta FR Collar 110 mm fitted on the exposed face	None.	-/60/60

Specimen	Aperture	Seal description	Service insulation	FRL
		(size 50 mm wide × 6.0 mm thick). FR Acrylic bead between pipe and floor.		
Q – Rehau Raupiano Plus PP-MD pipe with an outer diameter of Ø 125 mm and a pipe wall thickness of 3.1 mm	Ø 127 mm	Pipe capping: C/U Protecta FR Collar 125 mm fitted on the exposed face (size 60 mm wide × 9.0 mm thick). FR Acrylic bead between pipe and floor.	None.	-/180/180

warringtonfire

Proud to be part of  element



Warringtonfire Australia Pty Ltd
ABN 81 050 241 524

Perth

Unit 22, 22 Railway Road
Subiaco WA 6008
Australia
T: +61 8 9382 3844

Canberra

Unit 10, 71 Leichhardt Street
Kingston ACT 2604
Australia
T: +61 2 6260 8488

Melbourne

Level 9, 401 Collins Street
Melbourne VIC 3000
Australia
T: +61 3 9767 1000

Sydney

Suite 802, Level 8, 383 Kent Street
Sydney NSW 2000
Australia
T: +61 2 9211 4333

Brisbane

Suite 6, Level 12, 133 Mary Street
Brisbane QLD 4000
Australia
T: +61 7 3238 1700

Melbourne – NATA accredited laboratory

409-411 Hammond Road
Dandenong South VIC 3175
Australia
T: +61 3 9767 1000

General conditions of use

The data, methodologies, calculations and results documented in this report specifically relate to the tested specimen/s and must not be used for any other purpose. This report may only be reproduced in full. Extracts or abridgements must not be published without permission from Warringtonfire.

All work and services carried out by Warringtonfire are subject to, and conducted in accordance with our standard terms and conditions. These are available on request or at <https://www.element.com/terms/terms-and-conditions>.